



Generic Stream Encapsulation (GSE) Part 2: Logical Link Control (LLC)

DVB Document A116-2 Rev.3

September 2024

DVB[®]

Contents

Intellectual Property Rights	5
Foreword.....	5
Modal verbs terminology	5
Introduction	6
1 Scope.....	8
2 References	8
2.1 Normative references	8
2.2 Informative references	9
3 Symbols and abbreviations.....	10
3.1 Symbols	10
3.2 Abbreviations.....	10
4 Overview	11
5 Protocol Elements	11
5.0 LLC protocol architecture.....	11
5.1 Record Structures.....	13
5.1.1 Index Structure	13
5.1.1.0 Index structure syntax and semantics	13
5.1.1.1 Offset Mechanism	13
5.1.2 Link Control Data (LCD) records table.....	14
5.1.3 Network Control Data (NCD) records table.....	15
5.1.3.0 NCD records table syntax and carriage	15
5.1.3.1 Platform descriptors.....	15
5.1.3.2 Target descriptors	15
5.1.3.3 Operational descriptors.....	15
5.2 Descriptors.....	16
5.2.1 Descriptor identification and location	16
5.2.2 Descriptor coding.....	17
5.2.2.1 Application system descriptor	17
5.2.2.1.0 Application system descriptor syntax and semantics	17
5.2.2.1.1 OMA BCAST info.....	17
5.2.2.2 C2 PHY descriptor	19
5.2.2.2.1 Descriptor syntax and semantics.....	19
5.2.2.2.2 Link association descriptor selector fields content	20
5.2.2.3 DHCPv4 options descriptor.....	20
5.2.2.3.0 DHCPv4 options descriptor syntax and semantics	20
5.2.2.3.1 DHCPv4 options profile	21
5.2.2.4 DHCPv6 options descriptor.....	22
5.2.2.4.0 DHCPv6 options descriptor syntax and semantics	22
5.2.2.4.1 DHCPv6 options profile	23
5.2.2.5 IP/MAC generic stream location descriptor	24
5.2.2.6 IP/MAC link location descriptor	24
5.2.2.7 IP/MAC stream location descriptor.....	24
5.2.2.8 Link association descriptor.....	25
5.2.2.9 NGH PHY descriptor.....	26
5.2.2.10 ROHC-U descriptor.....	29
5.2.2.11 S2 PHY descriptor.....	30
5.2.2.12 S2X PHY descriptor	31
5.2.2.12.1 Descriptor syntax and semantics.....	31
5.2.2.12.2 Link association descriptor selector fields content	32
5.2.2.13 T2 PHY descriptor.....	33
5.2.2.14 URI descriptor	34
5.2.2.15 IP Multicast List descriptor	35

5.2.2.16	IPv6 Multicast List descriptor	36
5.2.2.17	RoHC-U Multicast descriptor.....	37
5.2.2.18	S2Xv2 PHY descriptor	38
5.2.2.18.1	Descriptor syntax and semantics.....	38
5.2.2.18.2	Link association descriptor selector fields content	40
5.2.3	Rules for future extensibility of descriptors	41
6	Transport in GSE Packets	42
6.0	Carriage in extension headers	42
6.1	GSE Header Fields.....	42
6.1.1	Start Indicator and End Indicator	42
6.1.2	Label Type Indicator	42
6.1.3	Protocol Type	42
6.1.4	Extension Header Byte.....	42
6.1.5	PDU Data Byte.....	43
6.2	GSE Table Structure Fields	43
6.2.0	General	43
6.2.1	Table ID	43
6.2.2	Interactive Network ID.....	43
6.2.3	Version Number and Current/Next Indicator	43
6.3	Combining Streams From Different Interactive Networks	44
7	Deployment Profiles.....	44
7.1	Bi-directional interface emulation	44
7.2	Generic network service profile.....	44
7.3	Application system profile.....	45
7.3.0	General use of the application system profile	45
7.3.1	OMA BCAST system profile	45
Annex A (informative): Examples.....		46
A.1	Carriage of LLC data in extension headers	46
A.2	Finding the size of the last table.....	47
A.3	Underlying data model	48
A.4	Use of Link Control Data	51
A.4.1	Carriage of Links on different physical layers.....	51
A.4.2	Use of physical layer channel aggregation modes	52
A.4.2.1	DVB-C2 channel bundling.....	52
A.4.2.2	DVB-S2X channel bonding and time slicing	53
A.4.3	Example of Multicast transport.....	54
Annex B (informative): Change History		55
History		56

Intellectual Property Rights

IPRs essential or potentially essential to the present document may have been declared to ETSI. The information pertaining to these essential IPRs, if any, is publicly available for **ETSI members and non-members**, and can be found in ETSI SR 000 314: "*Intellectual Property Rights (IPRs); Essential, or potentially Essential, IPRs notified to ETSI in respect of ETSI standards*", which is available from the ETSI Secretariat. Latest updates are available on the ETSI Web server (<https://ipr.etsi.org>).

Pursuant to the ETSI IPR Policy, no investigation, including IPR searches, has been carried out by ETSI. No guarantee can be given as to the existence of other IPRs not referenced in ETSI SR 000 314 (or the updates on the ETSI Web server) which are, or may be, or may become, essential to the present document.

Foreword

This Technical Specification (TS) has been produced by Joint Technical Committee (JTC) Broadcast of the European Broadcasting Union (EBU), Comité Européen de Normalisation ELECTrotechnique (CENELEC) and the European Telecommunications Standards Institute (ETSI).

NOTE: The EBU/ETSI JTC Broadcast was established in 1990 to co-ordinate the drafting of standards in the specific field of broadcasting and related fields. Since 1995 the JTC Broadcast became a tripartite body by including in the Memorandum of Understanding also CENELEC, which is responsible for the standardization of radio and television receivers. The EBU is a professional association of broadcasting organizations whose work includes the co-ordination of its members' activities in the technical, legal, programme-making and programme-exchange domains. The EBU has active members in about 60 countries in the European broadcasting area; its headquarters is in Geneva.

European Broadcasting Union
CH-1218 GRAND SACONNEX (Geneva) Switzerland
Tel: +41 22 717 21 11
Fax: +41 22 717 24 81

The Digital Video Broadcasting Project (DVB) is an industry-led consortium of broadcasters, manufacturers, network operators, software developers, regulatory bodies, content owners and others committed to designing global standards for the delivery of digital television and data services. DVB fosters market driven solutions that meet the needs and economic circumstances of broadcast industry stakeholders and consumers. DVB standards cover all aspects of digital television from transmission through interfacing, conditional access and interactivity for digital video, audio and data. The consortium came together in 1993 to provide global standardization, interoperability and future proof specifications.

The present document is part 2 of a multi-part deliverable covering the Digital Video Broadcasting (DVB); Generic Stream Encapsulation (GSE), as identified below:

- Part 1: "Protocol";
- Part 2: "Logical Link Control (LLC)";**
- Part 3: "Robust Header Compression (ROHC) for IP".

Modal verbs terminology

In the present document "**shall**", "**shall not**", "**should**", "**should not**", "**may**", "**need not**", "**will**", "**will not**", "**can**" and "**cannot**" are to be interpreted as described in clause 3.2 of the [ETSI Drafting Rules](#) (Verbal forms for the expression of provisions).

"**must**" and "**must not**" are **NOT** allowed in ETSI deliverables except when used in direct citation.

Introduction

As introduced in ETSI TS 102 606-1 [1], the Generic Stream Encapsulation (GSE) protocol is a link layer which provides multiplexing mechanisms that make it possible for several network protocols (for example IP, IPX, Decnet, and Appletalk) to coexist within a multipoint network and to be transported over the same network media. GSE is designed to be deployed across all DVB broadcast bearers which provide a Generic Stream mode.

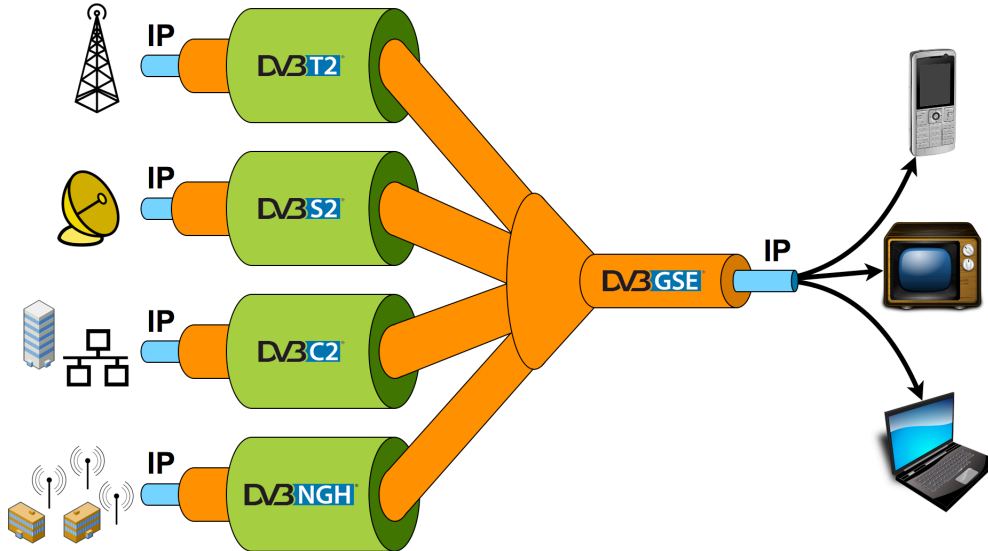

Figure 1: Role of DVB-GSE across broadcast bearers

This abstraction from the MAC layer allows to provision services on top of network protocols independently of the underlying physical layer. This is illustrated from a network operator's perspective in Figure 1, and from a protocol stack perspective in Figure 2.

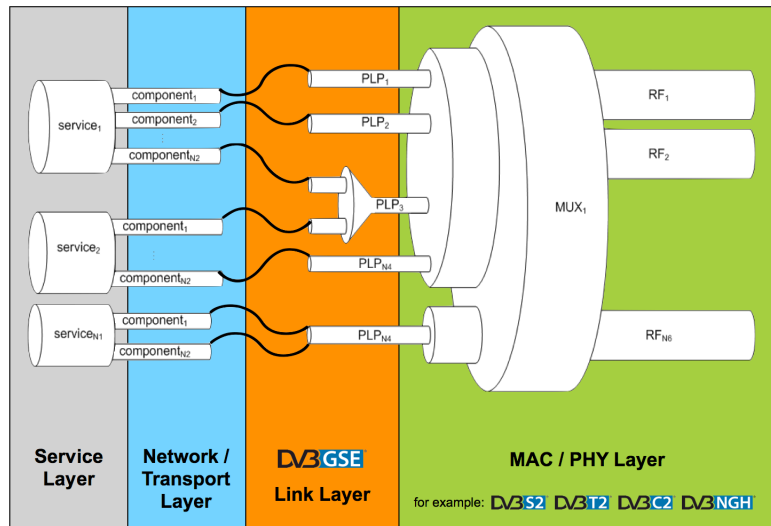

Figure 2: Protocol layers when using DVB-GSE

As shown in Figure 2, the DVB-GSE link layer hides any MAC layer specifics from the upper layers. It thus enables receivers to present DVB-GSE streams as regular, LAN-type network interfaces to upper layers. The logical link control protocol defined in the present document provides the necessary information to receivers to accomplish this.

On a Point-to-Point Protocol (PPP) link according to IETF RFC 1661 [i.3], two hosts establish a connection on any point-to-point serial interface (e.g. RS-232), and exchange IP datagrams. The PPP implementation encapsulates this link as a normal network interface, so that applications can use it as if it were a regular LAN interface. To achieve this, a Link Control Protocol (LCP) for establishing, configuring, and testing the data-link connection, and a family of Network Control Protocols (NCPs) for establishing and configuring different network-layer protocols is defined in IETF RFC 1661 [i.3]. When the connection establishment begins, the two hosts first use the LCP to negotiate the configuration parameters (e.g. link speed) of the serial data link. After this is completed, the two hosts use the appropriate NCPs to negotiate the configuration of the network interface (e.g. use of IPv4 or IPv6, IP addresses to use), and thus conclude the connection establishment phase. After this, the hosts present new LAN-type network interfaces to applications running on them.

The LLC protocol for DVB-GSE adopts the same partitioning of information. One set of information is needed to enable the DVB-GSE layer to configure the underlying MAC and physical layer devices. This first set of information is referred to as Link Control Data (LCD) in the present document. A second set of information is needed to configure the network interfaces which represent the DVB-GSE streams and make them available for the upper layers. This second set of information is referred to as Network Control Data (NCD) in the present document.

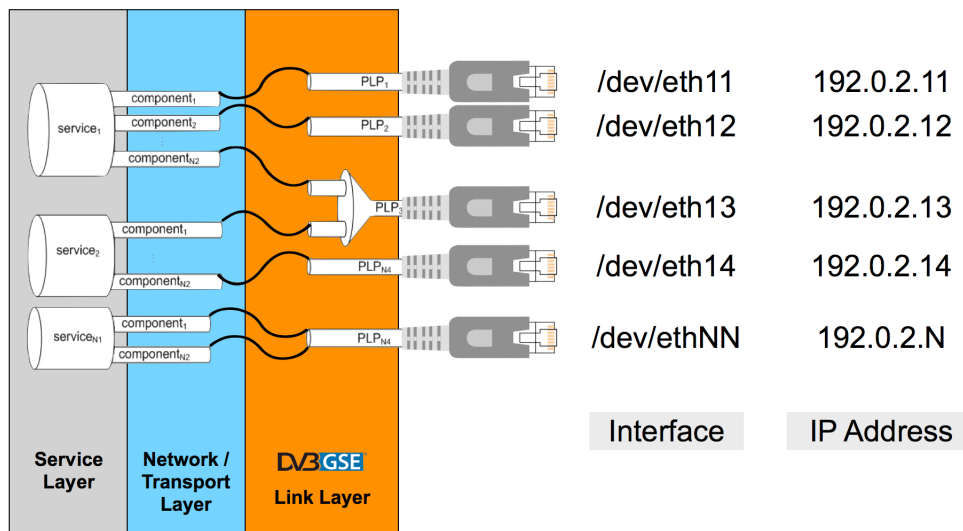

Figure 3: Application programming model of DVB-GSE with LLC

Once these network interfaces have been made available to the upper layers (see Figure 3), the properties of the MAC and physical layers are no longer exposed to upper layers, and applications can act on these interfaces like on any other network interface. Use of the tunnelling mechanism defined in IETF RFC 3077 [11] in combination with a return channel allows for the interfaces to be used for reading and writing.

1 Scope

The present document specifies a Logical Link Control (LLC) method to be used on DVB streams where the Generic Stream Encapsulation (GSE) [1] protocol is used as the link layer.

2 References

2.1 Normative references

References are either specific (identified by date of publication and/or edition number or version number) or non-specific. For specific references, only the cited version applies. For non-specific references, the latest version of the referenced document (including any amendments) applies.

Referenced documents which are not found to be publicly available in the expected location might be found at <http://docbox.etsi.org/Reference>.

NOTE: While any hyperlinks included in this clause were valid at the time of publication, ETSI cannot guarantee their long term validity.

The following referenced documents are necessary for the application of the present document.

- [1] ETSI TS 102 606-1: "Digital Video Broadcasting (DVB); Generic Stream Encapsulation (GSE); Part 1: Protocol".
- [2] ETSI TS 102 606-3: "Digital Video Broadcasting (DVB); Generic Stream Encapsulation (GSE); Part 3: Robust Header Compression (ROHC) for IP".
- [3] ETSI EN 301 192: "Digital Video Broadcasting (DVB); DVB specification for data broadcasting".
- [4] ETSI EN 301 545-2: "Digital Video Broadcasting (DVB); Second Generation DVB Interactive Satellite System (DVB-RCS2); Part 2: Lower Layers for Satellite standard".
- [5] ETSI EN 300 468: "Digital Video Broadcasting (DVB); Specification for Service Information (SI) in DVB systems".
- [6] ETSI TS 101 162: "Digital Video Broadcasting (DVB); Allocation of identifiers and codes for Digital Video Broadcasting (DVB) systems".
- [7] IETF RFC 2131: "Dynamic Host Configuration Protocol".
- [8] IETF RFC 2132: "DHCP Options and BOOTP Vendor Extensions".

NOTE: A complete list of all DHCP options defined by various sources is available from IANA at <http://www.iana.org/assignments/bootp-dhcp-parameters/bootp-dhcp-parameters.xml>.

- [9] IETF RFC 5795: "The Robust Header Compression (ROHC) Framework".
- [10] IETF RFC 3095: "Robust Header Compression (ROHC): Framework and four profiles: RTP, UDP, ESP, and uncompressed".
- [11] IETF RFC 3077: "A Link-Layer Tunneling Mechanism for Unidirectional Links".
- [12] ETSI EN 302 769: "Digital Video Broadcasting (DVB); Frame structure channel coding and modulation for a second generation digital transmission system for cable systems (DVB-C2)".
- [13] ETSI EN 302 755: "Digital Video Broadcasting (DVB); Frame structure channel coding and modulation for a second generation digital terrestrial television broadcasting system (DVB-T2)".
- [14] ETSI EN 302 307-1: "Digital Video Broadcasting (DVB); Second generation framing structure, channel coding and modulation systems for Broadcasting, Interactive Services, News Gathering and other broadband satellite applications; Part 1: DVB-S2".

- [15] DVB BlueBook A160: "Digital Video Broadcasting (DVB); Next Generation broadcasting system to Handheld, physical layer specification (DVB-NGH)".
- [16] IETF RFC 3986: "Uniform Resource Identifier (URI): Generic Syntax".
- [17] IANA: "Unidirectional Lightweight Encapsulation (ULE) Next-Header Registry".
- NOTE: See <http://www.iana.org/assignments/ule-next-headers/ule-next-headers.xml>.
- [18] IETF RFC 4776: "Dynamic Host Configuration Protocol (DHCPv4 and DHCPv6) Option for Civic Addresses Configuration Information".
- [19] IETF RFC 4833: "Timezone Options for DHCP".
- [20] IETF RFC 3011: "The IPv4 Subnet Selection Option for DHCP".
- [21] IETF RFC 3442: "The Classless Static Route Option for Dynamic Host Configuration Protocol (DHCP) version 4".
- [22] IETF RFC 3495: "Dynamic Host Configuration Protocol (DHCP) Option for CableLabs Client Configuration".
- [23] IETF RFC 6225: "Dynamic Host Configuration Protocol Options for Coordinate-Based Location Configuration Information".
- [24] IETF RFC 3315: "Dynamic Host Configuration Protocol for IPv6 (DHCPv6)".
- [25] IETF RFC 3633: "IPv6 Prefix Options for Dynamic Host Configuration Protocol (DHCP) version 6".
- [26] IETF RFC 6603: "Prefix Exclude Option for DHCPv6-based Prefix Delegation".
- [27] IETF RFC 3646: "DNS Configuration options for Dynamic Host Configuration Protocol for IPv6 (DHCPv6)".
- [28] IETF RFC 4326: "Unidirectional Lightweight Encapsulation (ULE) for Transmission of IP Datagrams over an MPEG-2 Transport Stream (TS)".
- [29] OMA BCAST DVB-NGH Adaptation: OMA-TS-BCAST-DVB-NGH-Adaptation: "BCAST Distribution System Adaptation - over DVB-NGH".
- NOTE: See <http://www.openmobilealliance.org>.
- [30] ETSI EN 302 307-2: "Digital Video Broadcasting (DVB); Second generation framing structure, channel coding and modulation systems for Broadcasting, Interactive Services, News Gathering and other broadband satellite applications; Part 2: DVB-S2 Extensions (DVB-S2X)".

2.2 Informative references

References are either specific (identified by date of publication and/or edition number or version number) or non-specific. For specific references, only the cited version applies. For non-specific references, the latest version of the referenced document (including any amendments) applies.

NOTE: While any hyperlinks included in this clause were valid at the time of publication, ETSI cannot guarantee their long term validity.

The following referenced documents are not necessary for the application of the present document but they assist the user with regard to a particular subject area.

- [i.1] ETSI TS 102 771: "Digital Video Broadcasting (DVB); Generic Stream Encapsulation (GSE) implementation guidelines".
- [i.2] ETSI TS 102 006: "Digital Video Broadcasting (DVB); Specification for System Software Update in DVB Systems".

[i.3] IETF RFC 1661: "The Point-to-Point Protocol (PPP)".

NOTE: The assigned Next-Header values are published at <http://www.iana.org/assignments/ule-next-headers/ule-next-headers.xml>.

[i.4] IETF RFC 3736: "Stateless Dynamic Host Configuration Protocol (DHCP) Service for IPv6".

[i.5] IEEE 1003.1™-2008: "Standard for Information Technology - Portable Operating System Interface (POSIX®)".

3 Symbols and abbreviations

3.1 Symbols

For the purposes of the present document, the symbols given in ETSI TS 102 606-1 [1] and the following apply:

123	A number without prefix denotes a decimal integer (base 10)
0x123	A number with a "0x" prefix denotes a hexadecimal integer (base 16)
0123	A number with a "0" prefix denotes an octal integer (base 8)
(1010) ₂	A number enclosed in parentheses, and with a number suffix denotes an integer to the base indicated by the suffix.

EXAMPLE: The representations for the number one-hundred and twenty three are: 123 to the base 10 (decimal), 0x7B to the base 16 (hexadecimal), 0173 to the base 8 (octal), and (1111011)₂ to the base 2 (binary).

NOTE: For binary and hexadecimal representations it may sometimes be convenient to group digits, and fill in leading zeroes to accommodate common word sizes. The number one-hundred and twenty three can hence for example also be represented as 0x007B, 0x0000 007B, (0111 1011)₂, or (0000 0000 0111 1011)₂.

3.2 Abbreviations

For the purposes of the present document, the abbreviations given in ETSI TS 102 606-1 [1] and the following apply:

BCAST	OMA Mobile Broadcast Services
GSE	Generic Stream Encapsulation
IANA	Internet Assigned Numbers Authority

NOTE: See <http://www.iana.org/>.

IP	Internet Protocol
ISP	Internet Service Provider
LAN	Local Area Network
LCD	Link Control Data
LLC	Logical Link Control
MAC	Media Access Control
NCD	Network Control Data
NSAP	Network Service Access Point
OMA	Open Mobile Alliance™

NOTE: See <http://www.openmobilealliance.org/>.

PLP	Physical Layer Pipe
-----	---------------------

NOTE: See ETSI EN 302 755 [13], ETSI EN 302 769 [12], and DVB BlueBook A160 [15].

SNPA	SubNetwork Point of Attachment
------	--------------------------------

4 Overview

To enable receivers to process LLC data in an efficient way, it is sent in GSE packets with a specific protocol type (see clause 6.1.3). This allows for very lightweight processing in the DVB-GSE layer: packets with the protocol type for LLC are processed within the GSE layer, all other packets are forwarded to higher layers.

The two sets of LLC data, the LCD for configuring the MAC and physical layer devices, and the NCD for configuring the network interfaces are transmitted in tables, which bear a `table_id` value for demultiplexing them. These LLC tables are carried in an extension header of LLC GSE packets. To provide faster access and support local caching mechanisms, an index structure is conveyed in an extension header. This scheme is shown in Figure 4.

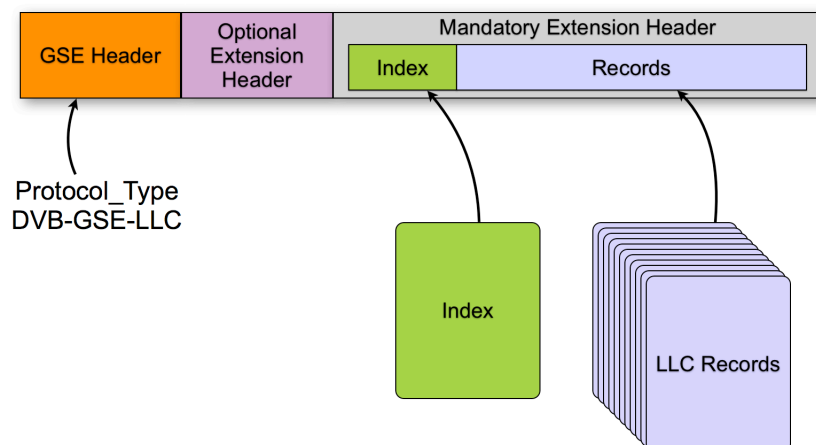
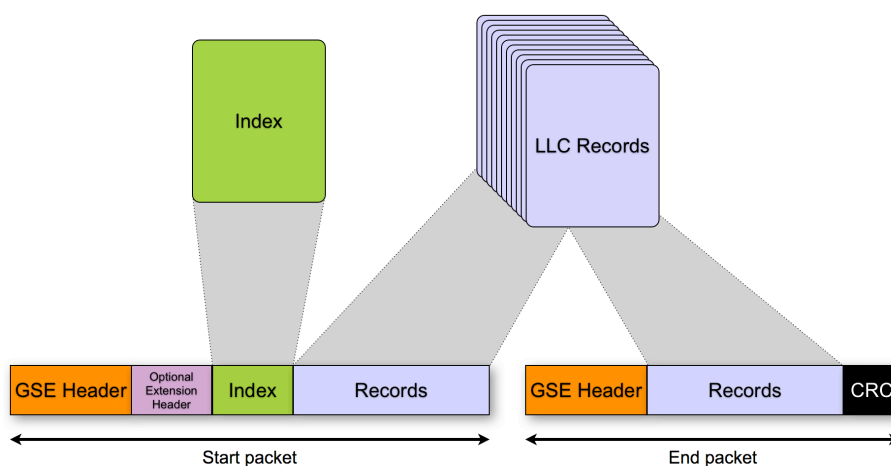

Figure 4: Basic scheme of LLC transport

To allow for large configurations, the LLC tables in the payload may of course be fragmented as defined in part 1 [1]. The basic fragmentation scheme is shown in Figure 5.



NOTE: For a definition of Start and End packet, see clause 4.2.3 of part 1 [1].

Figure 5: Basic scheme of fragmenting LLC data

5 Protocol Elements

5.0 LLC protocol architecture

This clause defines the data structures and the associated semantics that constitute the GSE LLC protocol. For information on how these data structures are conveyed, see clause 6.

The present document defines two table structures (see Figure 6):

- The first table structure (the LCD) conveys records describing the physical layer parameters in use on the broadcast links, and associates the data channels in the broadcast links with stream identifiers.
- The second table structure (the NCD) conveys records describing the network protocol configurations in use on the network interfaces, and associates the network interfaces with stream identifiers.

The concept of the stream identifier used in both record tables allows to associate network interfaces with broadcast links as shown in Figure 6. This partitioning of the information in link-related and network-related data allows for flexible end-to-end system management, where different entities can manage different parts or aspects of the operations. These entities can generate the LLC records describing the applied configurations independently. The use of the stream identifiers will only need to be coordinated when the set of streams changes, i.e. streams are added or removed from the system. For typical changes of operational parameters, e.g. a modulation parameter change on the broadcast physical layer, or the reallocation of a multicast group address to a different network interface, only the corresponding records table needs to be updated, while the other table may remain unchanged.

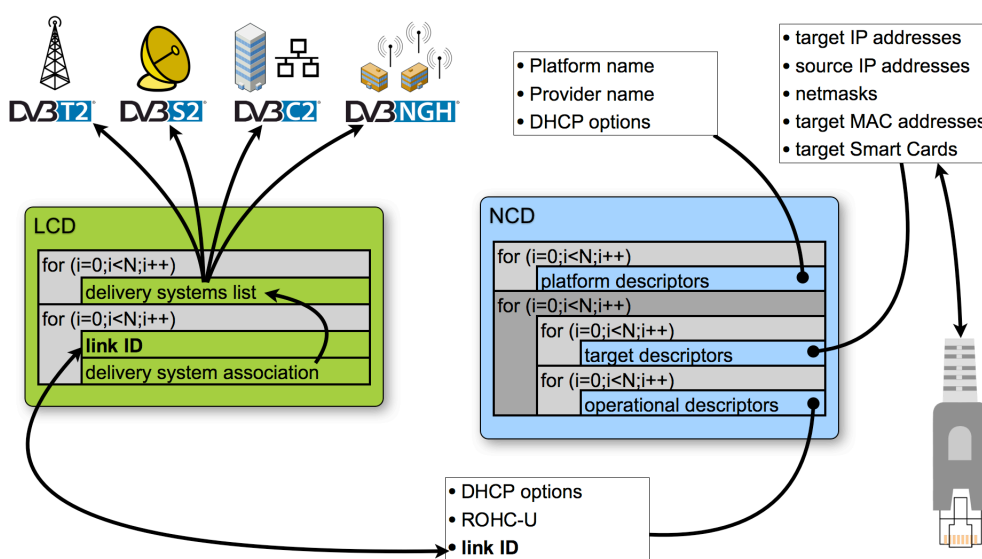

Figure 6: Overview of LLC record structures

For the sake of clarity and brevity, the syntax definitions in the present document make use of a template for descriptor loops. For the purposes of the present document, wherever a syntax element called "descriptor_loop()" - optionally preceded by a prefix - occurs, it shall be encoded according to Table 1.

Table 1: Descriptor loop template structure

Syntax	No. of Bits	Mnemonic	Applicable as of protocol version
<pre> descriptors() { descriptors_length for (i=0;i<N;i++) { descriptor() } } </pre>	16	uimsbf	0
	variable	bslbf	0

Semantics for the descriptor loop template:

descriptors_length: This 16-bit field specifies the number of bytes following for descriptors.

descriptor(): This variable size field conveys descriptors as applicable.

NOTE: The type and size of each of the descriptors can be inferred from its tag value and length field.

5.1 Record Structures

5.1.1 Index Structure

5.1.1.0 Index structure syntax and semantics

The LLC index structure provides information on the presence and location of LLC tables in the extension header, and on the version of each table to allow for timely detection and processing of any updates by receivers.

Table 2: Syntax of the Index Structure

Syntax	No. of Bits	Mnemonic	Applicable as of protocol version
LLC_index() {			
protocol_version	8	uimsbf	1
num_table_entries	8	uimsbf	0
for (i=0;i<N;i++) {			
table_id	8	uimsbf	0
reserved	2	bslbf	0
version	5	uimsbf	0
current_next_indicator	1	bslbf	0
offset	32	uimsbf	0
}			
}			

Semantics of the LLC index:

protocol_version: This 8-bit field that indicates the version of the LLC protocol used. It shall be encoded according to Table 3.

Table 3: Protocol version coding

protocol_version	Description
0	version 1.1.1 of the present document
1	version 1.2.1 of the present document
2	version 1.3.1 of the present document
3 to 255	reserved for future use

NOTE: This field was added with version 1.2.1 of the present document. Since it was inserted at the beginning of the index data structure, a parser implementing ETSI TS 102 606 V1.1.1 will not be able to process data encoded according to version 1.2.1 or later of the present document.

table_id, version, and current_next_indicator: These fields shall be set according to the corresponding fields in the gse_table_structure() being described by the instance of the loop.

offset: This 32-bit field indicates the offset of the first byte of the LLC table being described in the respective instance of the loop. It shall be encoded according to clause 5.1.1.1.

The LLC index shall correctly describe all the tables for the interactive network present in the stream up to (and including) the next GSE end packet carrying LLC data (see also Figure 7).

5.1.1.1 Offset Mechanism

For the calculation of the offset field in the LLC index structure, it is assumed that the index structure itself, and all LLC table structures are assembled in a theoretical buffer in the order they have been received. This is illustrated in Figure 7.

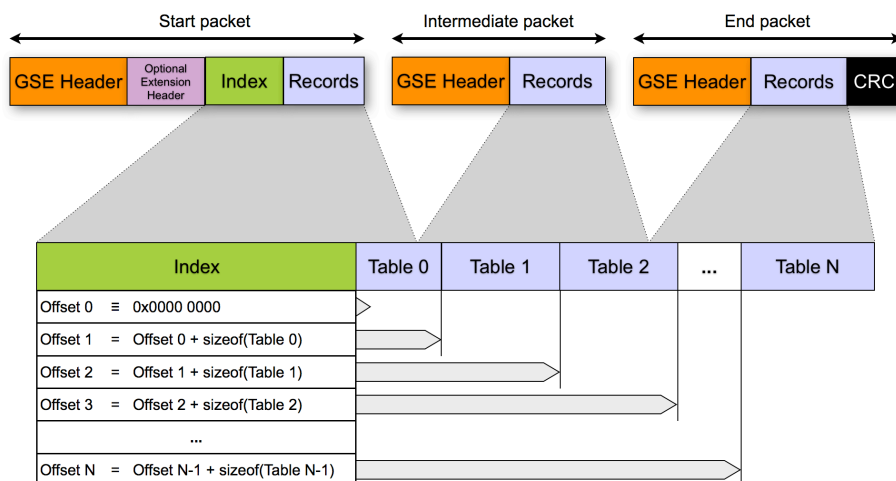

NOTE: For a definition of Start, Intermediate, and End packet, see clause 4.2.3 of part 1 [1].

Figure 7: Offset calculation scheme

Given this model, the value of the offset field shall be calculated as the number of bytes between the last byte of the index structure, and the first byte of the `gse_table_structure()` that is referenced. Hence, the offset of the first table (at index zero) shall always be set to zero as it immediately follows the index.

The offset of a given LLC table at index position n may hence be calculated as:

$$offset(n) = \begin{cases} 0 & \text{for } n = 0 \\ offset(n-1) + sizeof(table_{n-1}) & \text{for } n \geq 1 \end{cases}$$

The length of a given table can be calculated by subtracting the table's offset from the offset of the following table. Except for the last table, as in this case there is no following table. The end, and therefore the length of the last table can be determined by calculating the last table's effective offset relative to the end of the PDU. The end of the PDU can be inferred from the `Total_Length` field in the GSE header.

NOTE: For an example of finding the size of the last table in the index, see clause A.2.

5.1.2 Link Control Data (LCD) records table

The Link Control Data (LCD) provides information about the physical layer being used to transmit the link data streams.

It shall be carried in the `table_content_byte` field of a `gse_table_structure()` as defined in clause 6.2.

NOTE: For a complete example of the use of the `gse_table_structure()`, see Figure A.1.

Table 4: Syntax of the LCD

Syntax	No. of Bits	Mnemonic	Applicable as of protocol version
LCD() { PHY_descriptors() number_of_links for (i=0; i<N; i++) { link_id link_association_descriptors() } }	variable 16 16 variable	bslbf uimsbf uimsbf bslbf	0 0 0 0

Semantics of the LCD records table:

PHY_descriptors(): This variable size field describes the broadcast modulation systems associated with the interactive_network_id (see clause 6.2.2).

number_of_links: This 16-bit field indicates the number of link records following.

link_id: This 16-bit field uniquely identifies the physical link within the interactive_network_id (see clause 6.2.2).

link_association_descriptors(): This variable size field conveys link association descriptors according to clause 5.2.

5.1.3 Network Control Data (NCD) records table

5.1.3.0 NCD records table syntax and carriage

The Network Control Data provides information describing the Network Service Access Points (NSAP) which are provided by the network service. This information may be used by receivers to configure network interfaces as Sub-Network Points of Attachment (SNPA).

NOTE: The latter typically involves populating routing tables.

It shall be carried in the table_content_byte field of a gse_table_structure () as defined in clause 6.2.

NOTE: For a complete example of the use of the gse_table_structure(), see Figure A.1.

Table 5: Syntax of the NCD

Syntax	No. of Bits	Mnemonic	Applicable as of protocol version
NCD() { platform_descriptors() for (i=0;i<N;i++) { target_descriptors() operational_descriptors() } }	variable	bslbf	0
	variable	bslbf	0
	variable	bslbf	0

5.1.3.1 Platform descriptors

The platform_descriptors() carries information about the IP/MAC platform. It shall be encoded as a descriptor loop according to Table 1, and shall convey descriptors as defined in clause 5.2.

5.1.3.2 Target descriptors

The target_descriptors() discriminates between individual devices. It shall be encoded as a descriptor loop according to Table 1, and shall convey descriptors as defined in clause 5.2.

This descriptor loop may contain target IP/MAC address, smartcard or private, etc. descriptors. This descriptor loop forms a list of all target devices to be addressed and the operational loop applied. If this descriptor loop is empty, the operational loop applies to all devices.

A receiver device not recognizing a target descriptor (new or unknown target descriptor) shall assume this target descriptor does not target this receiver device.

5.1.3.3 Operational descriptors

The operational_descriptors() contains action, informational, and operational descriptors, which apply only to those target devices that meet the requirements of the target descriptor loop. It shall be encoded as a descriptor loop according to Table 1, and shall convey descriptors as defined in clause 5.2.

5.2 Descriptors

5.2.1 Descriptor identification and location

Table 6 lists the descriptors declared or defined within the present document, giving the descriptor_tag values and the intended placement within the LCD and the NCD. This does not imply that their use in other tables is restricted. Table 6 further partitions the descriptor_tag name space, and those descriptor_tag values within each range, which are not being assigned semantics in Table 6, shall be deemed to be reserved for future use.

Table 6: Identification and location of descriptors in LLC records

Name	Descriptor tag	LCD loop		NCD Loop			Note	Applicable as of protocol version
		PHY	Link	Platform	Target	Operational		
Descriptors defined in DVB-DATA [3] and DVB-SSU [i.2]	0x00 to 0x3F							
target_smartcard_descriptor	0x06				*		See ETSI EN 301 192 [3]	0
target_MAC_address_descriptor	0x07				*		See ETSI EN 301 192 [3]	0
target_serial_number_descriptor	0x08				*		See ETSI EN 301 192 [3]	0
target_IP_address_descriptor	0x09				*		See ETSI EN 301 192 [3]	0
target_IPv6_address_descriptor	0x0A				*		See ETSI EN 301 192 [3]	0
IP/MAC_platform_name_descriptor	0x0C			*			See ETSI EN 301 192 [3]	0
IP/MAC_platform_provider_name_descriptor	0x0D			*			See ETSI EN 301 192 [3]	0
target_MAC_address_range_descriptor	0x0E				*		See ETSI EN 301 192 [3]	0
target_IP_slash_descriptor	0x0F				*		See ETSI EN 301 192 [3]	0
target_IP_source_slash_descriptor	0x10				*		See ETSI EN 301 192 [3]	0
target_IPv6_slash_descriptor	0x11				*		See ETSI EN 301 192 [3]	0
target_IPv6_source_slash_descriptor	0x12				*		See ETSI EN 301 192 [3]	0
IP/MAC_generic_stream_location_descriptor	0x15					*	See ETSI EN 301 192 [3]	0
IP/MAC_stream_location_descriptor	0x13					*	See ETSI EN 301 192 [3]	0
Descriptors defined in the present document	0x40 to 0xFF							
S2 PHY descriptor	0x40	*					clause 5.2.2.11	0
T2 PHY descriptor	0x41	*					clause 5.2.2.13	0
C2 PHY descriptor	0x42	*					clause 5.2.2.2	0
NGH PHY descriptor	0x43	*					clause 5.2.2.9	0
link_association_descriptor	0x44		*				clause 5.2.2.8	0
application_system_descriptor	0x50			*		*	clause 5.2.2.1	0
DHCPv4_options_descriptor	0x51			*		*	clause 5.2.2.3	0
DHCPv6_options_descriptor	0x52			*		*	clause 5.2.2.4	0
ROHC-U_descriptor	0x53			*		*	clause 5.2.2.10	0
URI_descriptor	0x54					*	clause 5.2.2.14	0
IP/MAC_link_location_descriptor	0x55					*	clause 5.2.2.6	0
S2X PHY descriptor	0x56	*					clause 5.2.2.12	1
IP_multicast_list_descriptor	0x60				*	*	clause 5.2.2.15	2
IPv6_multicast_list_descriptor	0x61				*	*	clause 5.2.2.16	2
ROHC-U_multicast_descriptor	0x62					*	clause 5.2.2.17	2
S2Xv2_PHY_descriptor	0x57	*					Clause 5.2.2.18	2

5.2.2 Descriptor coding

5.2.2.1 Application system descriptor

5.2.2.1.0 Application system descriptor syntax and semantics

The application system descriptor identifies the application system used in the IP/MAC stream. This information can assist receivers to optimize the service discovery process.

The following rules shall apply:

- a) Transmission of this descriptor is optional.
- b) More than one instance is allowed in a loop.

Table 7: Application system descriptor

Syntax	No. of Bits	Mnemonic	Applicable as of protocol version
<pre> application_system_descriptor() { descriptor_tag descriptor_length application_system_id selector_length if (application_system_id == OMA_BCAST) { OMA_BCAST_info() } else { for (i=0;i<N;i++) { selector_byte } } } </pre>	<p>8</p> <p>8</p> <p>16</p> <p>8</p> <p>8</p>	<p>uimsbf</p> <p>uimsbf</p> <p>uimsbf</p> <p>uimsbf</p> <p>bslbf</p>	<p>0</p> <p>0</p> <p>0</p> <p>0</p> <p>0</p>

Semantics of the application system descriptor:

application_system_id: This 16-bit field identifies the application system used in the IP/MAC stream. It shall be encoded according to [6].

selector_length: This 8-bit field indicates the length in bytes of any following OMA BCAST info, or selector fields.

OMA_BCAST_info(): This field shall be encoded as defined in clause 5.2.2.1.1.

selector_byte: This is an 8-bit field. The sequence of selector_byte fields provides further information about the parameters used to operate the application system.

5.2.2.1.1 OMA BCAST info

The OMA BCAST info structure can provide a reference to a bootstrap session, and advance versioning information about elements of the OMA BCAST signalling as defined in [29]. Further details on the use of OMA BCAST over DVB-GSE can be found in [29].

Table 8: OMA BCAST info

Syntax	No. of Bits	Mnemonic	Applicable as of protocol version
OMA_BCAST_info() { bootstrap_session_info_flag L2_version_info_flag SG_content_verion_info_flag bootstrap_version_info_flag reserved_for_future_use if (bootstrap_session_info_flag == 1) { interactive_network_id modulation_system_type modulation_system_id PHY_stream_id } if (L2_version_info_flag == 1) { L2_version_info } if (SG_content_verion_info_flag == 1) { SG_content_version_info } if (bootstrap_sersion_info_flag == 1) { bootstrap_version_info } }	1 1 1 1 4 16 8 16 8 8 8 8	bslbf bslbf bslbf bslbf bslbf uimsbf uimsbf uimsbf uimsbf uimsbf uimsbf uimsbf	0 0 0 0 0 0 0 0 0 0 0 0

Semantics of the OMA BCAST info:

bootstrap_session_info_flag: This 1-bit field indicates the presence of the `interactive_network_id`, `modulation_system_type`, `modulation_system_id`, and `PHY_stream_id` fields. If it is set to one, those fields shall be present. If it is set to zero, those fields shall not be present.

L2_version_info_flag: This 1-bit field indicates the presence of the `L2_version_info` field. If it is set to one, that field shall be present. If it is set to zero, that field shall not be present.

SG_content_verion_info_flag: This 1-bit field indicates the presence of the `SG_content_version_info` field. If it is set to one, that field shall be present. If it is set to zero, that field shall not be present.

bootstrap_version_info_flag: This 1-bit field indicates the presence of the `bootstrap_version_info` field. If it is set to one, that field shall be present. If it is set to zero, that field shall not be present.

reserved_for_future_use: This 4-bit field is reserved for future use, and all bits shall be set to zero.

The following four fields, the `interactive_network_id`, the `modulation_system_type`, the `modulation_system_id`, and the `PHY_stream_id` together provide a reference to a GSE stream carrying data for a bootstrap session as defined in [29].

interactive_network_id: This 16-bit field identifies the interactive network carrying data for a bootstrap session as defined in [29].

modulation_system_type: This 8-bit field indicates the type of broadcast modulation system carrying data for a bootstrap session as defined in [29]. It shall be encoded as the `modulation_system_type` field of the `IP/MAC_generic_stream_location_descriptor` defined in ETSI EN 301 192 [3].

modulation_system_id: This 16-bit field indicates the system identifier used to identify the modulation parameters for the modulation system, within the `interactive_network_id` carrying data for a bootstrap session as defined in [29]. It shall be encoded as the `modulation_system_id` field of the `IP/MAC_generic_stream_location_descriptor` defined in ETSI EN 301 192 [3].

PHY_stream_id: This 8-bit field conveys the stream identifier of the Generic Stream within the modulation system identified by the `modulation_system_id` field carrying data for a bootstrap session as defined in [29]. It shall be encoded as the `PHY_stream_id` field of the `IP/MAC_generic_stream_location_descriptor` defined in ETSI EN 301 192 [3].

The following three fields, the `L2_version_info`, the `SG_content_version_info`, and the `bootstrap_version_info` provide advance versioning information about elements of the OMA BCAS^T signalling as defined in [29]. This information may be used by receivers to react appropriately to updates to the respective information.

L2_version_info: This 8-bit field indicates the version of the L2 information included in the SGDD data transmitted as part of the OMA BCAS^T service on top of IP [29]. The information conveyed in this field shall be updated whenever the L2 information included in the SGDD is updated to enable receivers to react appropriately.

SG_content_version_info: This 8-bit field indicates the version of the service guide information in the SG data transmitted as part of the OMA BCAS^T service on top of IP [29]. The information conveyed in this field shall be updated whenever the service guide information in the SG is updated to enable receivers to react appropriately.

bootstrap_version_info: This 8-bit field indicates the version of the bootstrap session data transmitted as part of the OMA BCAS^T service on top of IP [29]. The information conveyed in this field shall be updated whenever the bootstrap session data is updated to enable receivers to react appropriately.

5.2.2.2 C2 PHY descriptor

5.2.2.2.1 Descriptor syntax and semantics

The `C2_PHY_descriptor` shall be used to describe DVB-C2 transmissions according to ETSI EN 302 769 [12] within the `interactive_network_id` (see clause 6.2.2).

The following rules shall apply:

- a) Transmission of this descriptor is optional.
- b) More than one instance is allowed in a loop.
- c) The information from all instances in a loop shall be aggregated.

Table 9: C2 PHY descriptor

Syntax	No. of Bits	Mnemonic	Applicable as of protocol version
<code>C2_PHY_descriptor() {</code>			
<code>descriptor_tag</code>	8	uimbsf	0
<code>descriptor_length</code>	8	uimbsf	0
<code>C2_system_id</code>	16	uimbsf	0
<code>active_OFDM_symbol_duration</code>	3	bslbf	0
<code>guard_interval</code>	3	bslbf	0
<code>reserved_for_future_use</code>	3	bslbf	0
<code>PHY_stream_loop_length</code>	8	uimbsf	0
<code>for(i=0;i<N;i++) {</code>			
<code>PHY_stream_id</code>	16	uimbsf	0
<code>C2_System_tuning_frequency</code>	32	bslbf	0
<code>C2_System_tuning_frequency_type</code>	2	uimbsf	0
<code>reserved_for_future_use</code>	6	bslbf	0
<code>}</code>			
<code>}</code>			

Semantics of the C2 PHY descriptor:

C2_system_id: This 16-bit field uniquely identifies the C2 System within the `interactive_network_id` (see clause 6.2.2). The term is defined in ETSI EN 302 769 [12].

active_OFDM_symbol_duration: This field shall be encoded as defined in clause 6.4.5.1 of ETSI EN 302 769 [12].

guard_interval: This field shall be encoded as defined in clause 6.4.5.1 of ETSI EN 302 769 [12].

PHY_stream_loop_length: This 8-bit field indicates the length in bytes of the following PHY stream loop.

PHY_stream_id: This field shall be encoded as defined in clause 8.4.5.15 of ETSI EN 301 192 [3].

NOTE: The Data Slice identifier is encoded in the bits b_{15} through b_8 as a 8-bit uimbsf, and the Physical Layer Pipe (PLP) identifier is encoded in the bits b_7 through b_0 as an 8-bit uimbsf.

C2_System_tuning_frequency: This field shall be encoded as defined in clause 6.4.5.1 of ETSI EN 302 769 [12].

C2_System_tuning_frequency_type: This field shall be encoded as defined in clause 6.4.5.1 of ETSI EN 302 769 [12].

5.2.2.2.2 Link association descriptor selector fields content

When the modulation system type in the link association descriptor indicates the use of DVB-C2 transmissions according to ETSI EN 302 769 [12] using channel bundling, the selector fields in the link association descriptor shall be coded as follows:

- a) the selector_length_flag field shall be set to zero;

NOTE: This implies that the selector_length field and subsequent selector_byte fields are not present.

- b) the selector_flags field shall be coded according to Table 10.

Table 10: Selector flags for C2 channel bundling

Syntax	No. of Bits	Mnemonic	Applicable as of protocol version
C2_channel_bundling_info() { master_channel	1	uimbsf	1
reserved_zero_future_use }	6	bslbf	1

Semantics of the C2 channel bundling selector flags:

master_channel: This 1-bit field indicates whether the PLP indicated in the link association descriptor is using the master clock for the generation of the ISSY time stamps. If that PLP uses the master clock for ISSY generation, this field shall be set to '1'. Otherwise this field shall be set to '0'.

5.2.2.3 DHCPv4 options descriptor

5.2.2.3.0 DHCPv4 options descriptor syntax and semantics

This descriptor conveys a DHCP options field as defined in IETF RFC 2131 [7], IETF RFC 2132 [8], and as listed in the Dynamic Host Configuration Protocol (DHCP) and Bootstrap Protocol (BOOTP) Parameters registry at IANA (see note to IETF RFC 2132 [8]). This information shall be used by receivers to automate network-parameter assignment to network devices.

The following rules shall apply:

- Transmission of this descriptor is optional.
- More than one instance is allowed in a loop.
- The information from all instances in a loop shall be aggregated.
- The DHCPv4 options as defined in clause 5.2.2.3.1 shall be supported.

Table 11: DHCPv4 options descriptor

Syntax	No. of Bits	Mnemonic	Applicable as of protocol version
DHCPv4_options_descriptor() { descriptor_tag descriptor_length for (i=0;i<N;i++) { DHCPv4_option_byte } }	8	uimsbf	0
	8	uimsbf	0
	8	bslbf	0

Semantics of the DHCP options descriptor:

DHCPv4_option_byte: This field conveys a DHCP options field. This includes the termination of the options field by an end option and optional, subsequent pad options.

5.2.2.3.1 DHCPv4 options profile

The DHCPv4 option number space (1 to 254) is split into two parts. The site-specific option codes (128 to 254) are defined as "Private Use", and are implementation dependent.

The public option codes (0 to 127, and 255) are defined by a range of RFCs in addition to IETF RFC 2132 [8] and are detailed in Table 12. Options marked as "mandatory" shall be supported by receivers, options marked as "optional" should be supported by receivers, and options not listed in Table 12 may be ignored by receivers.

Table 12: DHCPv4 options profile

Option description	Reference (IETF RFC 2132 [8] unless otherwise stated)	Option number	Support in GSE LLC receivers
Pad	3.1	0	mandatory
End	3.2	255	mandatory
Subnet Mask	3.3	1	mandatory
Time Offset	3.4	2	mandatory
Router	3.5	3	mandatory if IETF RFC 3077 [11] is used as defined in clause 7.1
Time Server	3.6	4	mandatory
Domain Name Server	3.8	6	mandatory
Host Name	3.14	12	optional
Domain Name	3.17	15	mandatory
IP Forwarding Enable/Disable	4.1	19	optional
Non-Local Source Routing Enable/Disable	4.2	20	optional
Policy Filter	4.3	21	optional
Maximum Datagram Reassembly Size	4.4	22	optional
Default IP Time-to-live	4.5	23	optional
Interface MTU	5.1	26	optional
All Subnets are Local	5.2	27	optional
Broadcast Address	5.3	28	optional
Static Route	5.8	33	optional
TCP Default TTL	7.1	37	optional
TCP Keepalive Interval	7.2	38	optional
TCP Keepalive Garbage	7.3	39	optional
Network Time Protocol Servers	8.3	42	mandatory if NTP is used
Mobile IP Home Agent	8.13	68	mandatory for mobile receivers
Requested IP Address	9.1	50	mandatory if IETF RFC 3077 [11] is used as defined in clause 7.1
IP Address Lease Time	9.2	51	mandatory if IETF RFC 3077 [11] is used as defined in clause 7.1
Option Overload	9.3	52	mandatory
DHCP Message Type	9.6	53	mandatory
Server Identifier	9.7	54	mandatory

Option description	Reference (IETF RFC 2132 [8] unless otherwise stated)	Option number	Support in GSE LLC receivers
Parameter Request List	9.8	55	mandatory if IETF RFC 3077 [11] is used as defined in clause 7.1
Message	9.9	56	mandatory if IETF RFC 3077 [11] is used as defined in clause 7.1
Renewal (T1) Time Value	9.11	58	mandatory if IETF RFC 3077 [11] is used as defined in clause 7.1
Rebinding (T2) Time Value	9.12	59	mandatory if IETF RFC 3077 [11] is used as defined in clause 7.1
Client-identifier	9.14	61	mandatory if IETF RFC 3077 [11] is used as defined in clause 7.1
GEOCONF_CIVIC	IETF RFC 4776 [18]	99	mandatory (used for CellID locality determination)
PCode (IEEE 1003.1™ [i.5] TZ String)	IETF RFC 4833 [19] section 2	100	optional
TCode (Reference to the TZ Database)	IETF RFC 4833 [19] section 2	101	optional
Subnet Selection	IETF RFC 3011 [20]	118	mandatory if IETF RFC 3077 [11] is used as defined in clause 7.1
Classless Static Route	IETF RFC 3442 [21]	121	mandatory
CableLabs Client Configuration	IETF RFC 3495 [22]	122	optional
GeoConf	IETF RFC 6225 [23] section 2.2.1	123	optional

5.2.2.4 DHCPv6 options descriptor

5.2.2.4.0 DHCPv6 options descriptor syntax and semantics

IPv6 hosts can acquire IP addresses by either using stateless address autoconfiguration, or by using DHCPv6. DHCP may be preferred in situations where central management of hosts is important, such as a broadcast network using DVB-GSE for transmitting IP. Stateless autoconfiguration does not require any central management, and is therefore preferable in situations where no management is readily available, such as a typical home network. The DHCPv6 options descriptor can be used to centrally manage and configure the IPv6 interfaces associated with DVB-GSE streams.

The following rules shall apply:

- a) Transmission of this descriptor is optional.
- b) More than one instance is allowed in a loop.
- c) The information from all instances in a loop shall be aggregated.
- d) The DHCPv6 options as defined in clause 5.2.2.4.1 shall be supported.

Table 13: DHCPv6 options descriptor

Syntax	No. of Bits	Mnemonic	Applicable as of protocol version
DHCPv6_options_descriptor() { descriptor_tag descriptor_length for (i=0;i<N;i++) { DHCPv6_option_byte } }	8	uimsbf	0
	8	uimsbf	0
	8	bslbf	0

Semantics of the DHCP options descriptor:

DHCPv6_option_byte: This field conveys a DHCP options field. This includes the termination of the options field by an end option and optional, subsequent pad options.

5.2.2.4.1 DHCPv6 options profile

Options marked as "mandatory" in Table 14 shall be supported by receivers, options marked as "optional" should be supported by receivers, and options not listed in Table 14 may be ignored by receivers. Implementations should use the Stateless Dynamic Host Configuration Protocol (DHCP) Service for IPv6 as defined in IETF RFC 3736 [i.4] where appropriate.

Table 14: DHCPv6 options profile

Option description	Reference (IETF RFC 3315 [24] unless otherwise stated)	Option number	Support in GSE LLC receivers
Client Identifier	22.2	1	optional
Server Identifier	22.3	2	mandatory
Identity Association for Non-temporary Addresses	22.4	3	mandatory
Identity Association for Temporary Addresses	22.5	4	mandatory if IETF RFC 3077 [11] is used as defined in clause 7.1
IA Address	22.6	5	mandatory
Option Request	22.7	6	optional if IETF RFC 3077 [11] is used as defined in clause 7.1
Preference	22.8	7	mandatory
Elapsed Time	22.9	8	mandatory if IETF RFC 3077 [11] is used as defined in clause 7.1
Relay Message	22.10	9	mandatory if IETF RFC 3077 [11] is used as defined in clause 7.1
Authentication	22.11	11	optional
Server Unicast	22.12	12	mandatory if IETF RFC 3077 [11] is used as defined in clause 7.1
Status Code	22.13	13	mandatory
Rapid Commit	22.14	14	optional if IETF RFC 3077 [11] is used as defined in clause 7.1
User Class	22.15	15	optional if IETF RFC 3077 [11] is used as defined in clause 7.1
Vendor Class	22.16	16	optional if IETF RFC 3077 [11] is used as defined in clause 7.1
Vendor-specific Information	22.17	17	optional
Interface-Id	22.18	18	optional if IETF RFC 3077 [11] is used as defined in clause 7.1
Reconfigure Message	22.19	19	optional
Reconfigure Accept	22.20	20	optional if IETF RFC 3077 [11] is used as defined in clause 7.1
Identity Association for Prefix Delegation	IETF RFC 3633 [25] section 9	25	mandatory
IA_PD Prefix	IETF RFC 3633 [25] section 10	26	mandatory

Option description	Reference (IETF RFC 3315 [24] unless otherwise stated)	Option number	Support in GSE LLC receivers
Prefix Exclude	IETF RFC 6603 [26] section 4.2	67	mandatory
DNS Recursive Name Server	IETF RFC 3646 [27] section 3	23	mandatory if IETF RFC 3077 [11] is used as defined in clause 7.1
Domain Search List	IETF RFC 3646 [27] section 4	24	mandatory if IETF RFC 3077 [11] is used as defined in clause 7.1

5.2.2.5 IP/MAC generic stream location descriptor

The IP/MAC generic stream location descriptor associates a set of operational IP/MAC stream parameters in the NCD with a link in a different interactive network. It shall be encoded as defined in clause 8.4.5.15 of ETSI EN 301 192 [3].

NOTE: For associating operational parameters with links on the same interactive network, see clause 5.2.2.6.

The following rules shall apply:

- a) Transmission of this descriptor is optional.
- b) More than one instance is allowed in a loop.
- c) When it occurs more than once in a loop, each tuple of `interactive_network_id`, `modulation_system_type`, `modulation_system_id`, and `PHY_stream_id` shall be unique within that instance of the descriptors loop.

5.2.2.6 IP/MAC link location descriptor

The IP/MAC link location descriptor associates a set of operational IP/MAC stream parameters in the NCD with a link in the same interactive network.

The following rules shall apply:

- a) This descriptor shall be transmitted at least once in each instance of the operational descriptors loop of the NCD.
- b) When it occurs more than once in a loop, each value of `link_id` shall be unique within that instance of the descriptors loop.

Table 15: IP/MAC link location descriptor

Syntax	No. of Bits	Mnemonic	Applicable as of protocol version
<code>IP/MAC_link_location_descriptor() {</code>			
<code>descriptor_tag</code>	8	uimsbf	0
<code>descriptor_length</code>	8	uimsbf	0
<code>link_id</code>	16	uimsbf	0
<code>}</code>			

Semantics of the IP/MAC link location descriptor:

link_id: This 16-bit field uniquely identifies the physical link within the `interactive_network_id` (see clause 6.2.2), to which the operational parameters apply.

5.2.2.7 IP/MAC stream location descriptor

The IP/MAC stream location descriptor associates a set of operational IP/MAC stream parameters in the NCD with an IP/MAC stream carried in MPE sections in DVB Transport Streams according to clause 7 of ETSI EN 301 192 [3]. It shall be encoded as defined in clause 8.4.5.14 of ETSI EN 301 192 [3].

NOTE: Transmissions of IP/MAC streams in MPE sections may use additional signalling on the DVB Transport Stream according to clause 8 of ETSI EN 301 192 [3].

The following rules shall apply:

- a) Transmission of this descriptor is optional.
- b) More than one instance is allowed in a loop.
- c) When it occurs more than once in a loop, each tuple of `network_id`, `original_network_id`, `transport_stream_id`, `service_id`, and `component_tag` shall be unique within that instance of the descriptors loop.

5.2.2.8 Link association descriptor

The link association descriptor associates a Generic Stream in a DVB system with a link in the LCD.

The following rules shall apply:

- a) This descriptor shall be transmitted at least once in each instance of the link association descriptors loop of the LCD.
- b) When it occurs more than once in a loop, each tuple of `modulation_system_type`, `modulation_system_id`, and `PHY_stream_id` shall be unique within that instance of the descriptors loop.

Table 16: Link association descriptor

Syntax	No. of Bits	Mnemonic	Applicable as of protocol version
<code>Link_association_descriptor() {</code>			
<code>descriptor_tag</code>	8	uimsbf	0
<code>descriptor_length</code>	8	uimsbf	0
<code>modulation_system_type</code>	8	uimsbf	0
<code>modulation_system_id</code>	16	uimsbf	0
<code>PHY_stream_id</code>	16	uimsbf	0
<code>selector_length_flag</code>	1	uimsbf	1
<code>if (selector_length_flag == 0) {</code>			
<code>selector_flags</code>	7	bslbf	1
<code>}</code>			
<code>else {</code>			
<code>selector_length</code>	7	uimsbf	1
<code>for(i=0;i<N;i++) {</code>			
<code>selector_byte</code>	8	bslbf	1
<code>}</code>			
<code>}</code>			
<code>}</code>			

Semantics of the link association descriptor:

modulation_system_type: This 8-bit field indicates the type of broadcast modulation system. It shall be encoded as the `modulation_system_type` field of the `IP/MAC_generic_stream_location_descriptor` defined in ETSI EN 301 192 [3].

modulation_system_id: This 16-bit field indicates the system identifier used to identify the modulation parameters for the modulation system, within the `interactive_network_id`. It shall be encoded as the `modulation_system_id` field of the `IP/MAC_generic_stream_location_descriptor` defined in ETSI EN 301 192 [3].

PHY_stream_id: This 16-bit field conveys the stream identifier of the Generic Stream within the modulation system identified by the `modulation_system_id` field. It shall be encoded as the `PHY_stream_id` field of the `IP/MAC_generic_stream_location_descriptor` defined in ETSI EN 301 192 [3].

selector_length_flag: This 1-bit field indicates the type of selector information following. When set to zero, a 7-bit selector field follows. Otherwise, an 8-bit selector length field follows, indicating the number of selector bytes following.

NOTE: If more than one PHY stream is being associated with a link_id via this descriptor, the modulation system type specific information can help receivers determine the semantics of this 1:N mapping, e.g. by marking one of the PHY streams as a "master stream" which can be used as an entry point for acquiring the link.

selector_flags: This 7-bit field conveys additional information about the PHY stream. The format and contents of this field depend on the modulation system type.

selector_length: This 7-bit field conveys the number of selector byte fields following.

selector_byte: This is an 8-bit field. The sequence of selector byte fields conveys additional information about the PHY stream. The format and contents of this field depend on the modulation system type.

For the modulation system types listed in Table 17, the selector fields shall be coded according to the clause indicated in Table 17 for the respective modulation system type. For all other modulation system types, or where no additional information is to be given for one of the types listed in Table 17, the selector_length_flag field shall be set to zero, and it shall be followed by a selector_flags field with all bits set to zero.

NOTE: Examples for use of the selector field are provided in annex A.

Table 17: Modulation system specific selector fields

Modulation system type	Selector fields content defined in
DVB-C2 [12]	clause 5.2.2.2.2
DVB-S2X [30]	clause 5.2.2.12.2
DVB-S2Xv2 [Annex E of 30]	clause 5.2.2.18.2

5.2.2.9 NGH PHY descriptor

The NGH_PHY_descriptor shall be used to describe DVB-NGH transmissions according to DVB BlueBook A160 [15] within the interactive_network_id (see clause 6.2.2).

The following rules shall apply:

- a) Transmission of this descriptor is optional.
- b) More than one instance is allowed in a loop.
- c) The information from all instances in a loop shall be aggregated.

Table 18: NGH PHY descriptor

Syntax	No. of Bits	Mnemonic	Applicable as of protocol version
NGH_PHY_descriptor() {			
descriptor_tag	8	uimbsf	0
descriptor_length	8	uimbsf	0
NGH_system_id	16	uimbsf	0
bandwidth	4	uimbsf	0
transmission_mode	3	uimbsf	0
other_frequency_flag	1	uimbsf	0
guard_interval	4	uimbsf	0
network_sync_flag	1	uimbsf	0
reserved_for_future_use	2	bslbf	0
tfs_flag	1	uimbsf	0
reserved_for_future_use	4	bslbf	0
common_clock_reference_id	4	uimbsf	0
plp_loop_length	16	uimbsf	0
for (i=0;i<N;i++) {			
plp_id	8	uimbsf	0
IO_mode	4	uimnsf	0
reserved_for_future_use	4	bslbf	0
}			
cell_loop_length	16	uimbsf	0
for (i=0;i<N;i++) {			
cell_id	16	uimbsf	0
if (tfs_flag == 1) {			
frequency_loop_length	8	uimbsf	0
for (i=0;i<N;i++) {			
centre_frequency	32	uimbsf	0
}			
}			
else {			
centre_frequency	32	uimbsf	0
}			
subcell_info_loop_length	8	uimbsf	0
for (i=0;i<N;i++) {			
cell_id_extension	8	uimbsf	0
transposer_frequency	32	uimbsf	0
}			
}			

Semantics of the NGH PHY descriptor:

NGH_system_id: This 16-bit field uniquely identifies the NGH System within the interactive_network_id (see clause 6.2.2). The term is defined in DVB BlueBook A160 [15].

bandwidth: This 4-field indicates the channel bandwidth used by the NGH system. It shall be encoded according to Table 19.

Table 19: Encoding of the bandwidth

bandwidth	Description
0	20 MHz
1	15 MHz
2	10 MHz
3	8 MHz
4	7 MHz
5	6 MHz
6	5 MHz
7	1,7 MHz
8 to 15	reserved for future use

transmission_mode: This 3-bit field indicates the FFT size of the transmitted signals. It shall be encoded according to Table 20.

Table 20: Encoding of the transmission mode

transmission_mode	Description
0	2k mode
1	4k mode
2	8k mode
3	16k mode
4 to 7	reserved for future use

other_frequency_flag: This 1-bit flag indicates whether other frequencies (non-TFS case) or other groups of frequencies (TFS case) are in use. The value 0 (zero) indicates that the set of frequencies (non-TFS case) or the set of groups of frequencies (TFS case) included in the descriptor is complete, whereas the value 1 (one) indicates that the set is incomplete.

guard_interval: This 3-bit field indicates the guard interval. It shall be encoded according to Table 21.

Table 21: Encoding of the guard interval

guard_interval	Description
0	1/32
1	1/16
2	1/8
3	1/4
4	1/128
5	19/128
6	19/256
7	reserved for future use

network_sync_flag: This 1-bit flag conveys information about whether the start of super-frames is synchronized in time across all transmitted signals of the NGH System. A value of 1 (one) indicates that they are synchronized within the NGH System. A value of 0 (zero) indicates that they are not synchronized within the NGH System.

tfs_flag: This 1-bit flag indicates whether a TFS arrangement is in place or not. A value of 0 (zero) indicates that no TFS arrangement is in place, whereas a value of 1 (one) indicates that a TFS arrangement is in place.

common_clock_reference_id: This 4-bit field indicates whether the signal in the current T2 multiplex or system is synchronized with other multiplexes or systems within the same network, and if synchronized it gives the ID of the clock reference it uses in common with other multiplexes or systems according to Table 29. This field will allow for fast zapping to a multiplex the receiver has previously visited.

Table 22: Common clock reference ID coding

common_clock_reference_id	Description
0	Not synchronized
1	Synchronized with clock ID 1
2	Synchronized with clock ID 2
3	Synchronized with clock ID 3
4	Synchronized with clock ID 4
5	Synchronized with clock ID 5
6	Synchronized with clock ID 6
7	Synchronized with clock ID 7
8 to 15	reserved for future use

plp_loop_length: This 16-bit field indicates the length in bytes of the following PLP loop.

plp_id: This 8-bit field uniquely identifies a data PLP within an NGH system, within an NGH network

IO_mode: This 4-bit field indicates the single/multiple input/output mode applied to the PLP, and - in the case of MISO PLPs - the frame type they are carried in. It shall be encoded according to Table 23.

Table 23: Encoding of the IO mode

IO_mode	Description
0	SISO
1	MISO (carried in MISO frames)
2	MISO (carried in MIMO frames)
3	MIMO
4 to 15	reserved for future use

cell_loop_length: This 16-bit field indicates the length in bytes of the following cell and subcell loops.

cell_id: This 16-bit field uniquely identifies a cell, as defined in DVB BlueBook A160 [15].

frequency_loop_length: This 8-bit field indicates the length in bytes of the following frequency loop.

centre_frequency: This 32-bit field indicates the frequency value in multiples of 10 Hz. The coding range is from minimum 10 Hz (0x00000001) up to a maximum of 42 949 672 950 Hz (0xFFFFFFFF).

subcell_info_loop_length: This 8-bit field indicates the length in bytes of the following subcell loop.

cell_id_extension: This 8-bit field is used to identify a sub-cell within a cell.

transposer_frequency: This 32-bit field indicates the centre frequency that is used by a transposer in the sub-cell indicated. It shall be encoded in the same way as the centre_frequency field.

5.2.2.10 ROHC-U descriptor

This descriptor conveys configuration parameters for the Robust Header Compression [9] decompressor in Unidirectional mode of operation (ROHC-U, defined in section 4.4.1 of IETF RFC 3095 [10]) for GSE streams which use ROHC for IP as defined in ETSI TS 102 606-3 [2].

The following rules shall apply:

- a) Transmission of this descriptor is optional.
- b) Only one instance with the same context_id is allowed in a loop.

Table 24: ROHC-U descriptor

Syntax	No. of Bits	Mnemonic	Applicable as of protocol version
ROHC-U_descriptor() {			
descriptor_tag	8	uimbsf	0
descriptor_length	8	uimbsf	0
rohc_ch_id	16	uimbsf	2
context_id	8 or 16	bslbf	0
context_profile	8	uimbsf	0
static_chain_length	8	uimbsf	0
for (i=0; i<N; i++) {			
static_chain_byte	8	bslbf	0
}			
}			

Semantics of the ROHC-U descriptor:

rohc_ch_id: This 16-bit field indicates the ROHC channel corresponding to this descriptor. The ROHC channel can be mapped to physical layer stream. If single ROHC channel is configured in the physical link, the rohc_ch_id can be the same value with link_id.

context_id: This 8-bit or 16-bit field indicates the context id (CID) of the compressed IP stream. It shall be encoded as defined in clause 5.1.3 of IETF RFC 3095 [10].

NOTE: Clause 5.1.3 of IETF RFC 3095 [10] defines that ROHC uses either a small or a large CID, and that it is encoded using the self-describing variable-length encoding (defined in clause 4.5.6 of IETF RFC 3095 [10]) with the field size limited to two octets.

context_profile: This 8-bit field indicates the range of protocols used to compress the stream. It shall convey the eight least significant bits of the ROHC profile identifier defined in clause 4.1.1 of ETSI TS 102 606-3 [2].

static_chain_length: This 8-bit field indicates the length of the static chain byte sequence.

static_chain_byte: This field conveys the static information used to initialize the ROHC-U decompressor. The size and structure of this field depend on the context profile.

5.2.2.11 S2 PHY descriptor

The S2_PHY_descriptor shall be used to describe DVB-S2 transmissions according to ETSI EN 302 307-1 [14] within the interactive_network_id (see clause 6.2.2).

The following rules shall apply:

- a) Transmission of this descriptor is optional.
- b) More than one instance is allowed in a loop.
- c) The information from all instances in a loop shall be aggregated.

Table 25: S2 PHY descriptor

Syntax	No. of Bits	Mnemonic	Applicable as of protocol version
S2_PHY_descriptor() {			
descriptor_tag	8	uimsbf	0
descriptor_length	8	uimsbf	0
S2_system_id	16	uimsbf	0
frequency	32	bslbf	0
symbol_rate	28	bslbf	0
west_east_flag	1	uimsbf	0
scrambling_sequence_selector	1	uimsbf	0
reserved_zero_for_future_use	4	bslbf	0
polarization	2	uimsbf	0
timeslice_flag	1	uimsbf	1
roll_off	2	uimsbf	0
reserved_zero_for_future_use	1	bslbf	0
TYPE	2	uimsbf	0
reserved_zero_for_future_use	1	bslbf	0
MODCOD	5	uimsbf	0
orbital_position	16	bslbf	0
if (scrambling_sequence_selector == 1){			
reserved_for_future_use	6	bslbf	0
scrambling_sequence_index	18	uimsbf	0
}			
}			

Semantics of the S2 PHY descriptor:

S2_system_id: This 16-bit field uniquely identifies the S2 System within the interactive_network_id (see clause 6.2.2). The term is defined in ETSI EN 302 307-1 [14].

frequency: This field shall be encoded as defined in clause 6.2.13.2 of ETSI EN 300 468 [5].

symbol_rate: This field shall be encoded as defined in clause 6.2.13.2 of ETSI EN 300 468 [5].

west_east_flag: This field shall be encoded as defined in clause 6.2.13.2 of ETSI EN 300 468 [5].

scrambling_sequence_selector: This field shall be encoded as defined in clause 6.2.13.3 of ETSI EN 300 468 [5].

polarization: This field shall be encoded as defined in clause 6.2.13.2 of ETSI EN 300 468 [5].

timeslice_flag: This 1-bit field indicates the use of time slicing as defined in annex M of ETSI EN 302 307-1 [14]. When set to zero, it indicates that time slicing is not used. When set to one, it indicates that time slicing is used.

NOTE 1: This field was introduced with protocol version 1. In protocol version 0 it was reserved zero for future use. This reassignment is backwards compatible, since time slicing was added to DVB-S2 after protocol version 0 was published.

NOTE 2: When time slicing is used, the timeslice_number can be inferred from the PHY_stream_ID (see clause 5.2.2.8).

roll_off: This field shall be encoded as defined in clause 6.2.13.2 of ETSI EN 300 468 [5].

TYPE: This field shall be encoded as defined in clause 5.5.2.3 of ETSI EN 302 307-1 [14].

MODCOD: This field shall be encoded as defined in clause 5.5.2.2 of ETSI EN 302 307-1 [14].

orbital_position: This field shall be encoded as defined in clause 6.2.13.2 of ETSI EN 300 468 [5].

scrambling_sequence_index: This field shall be encoded as defined in clause 6.2.13.3 of ETSI EN 300 468 [5].

5.2.2.12 S2X PHY descriptor

5.2.2.12.1 Descriptor syntax and semantics

The S2X_PHY_descriptor shall be used to describe DVB-S2X transmissions according to ETSI EN 302 307-2 [30] within the interactive_network_id (see clause 6.2.2).

The following rules shall apply:

- a) Transmission of this descriptor is optional.
- b) More than one instance is allowed in a loop.
- c) The information from all instances in a loop shall be aggregated.

Table 26: S2X PHY descriptor

Syntax	Number of bits	Identifier	Applicable as of protocol version
S2X_PHY_descriptor() {			
descriptor_tag	8	uimsbf	1
descriptor_length	8	uimsbf	1
S2X_system_id	16	uimsbf	1
receiver_profiles	5	bslbf	1
reserved_zero_future_use	3	bslbf	1
S2X_mode	2	uimsbf	1
polarization	2	bslbf	1
west_east_flag	1	bslbf	1
scrambling_sequence_selector	1	bslbf	1
reserved_zero_future_use	2	bslbf	1
if (scrambling_sequence_selector == 1) {			
reserved_zero_future_use	6	bslbf	1
scrambling_sequence_index	18	uimsbf	1
}			
frequency	32	bslbf	1
orbital_position	16	bslbf	1
reserved_zero_future_use	5	bslbf	1
roll_off	3	bslbf	1
reserved_zero_future_use	4	bslbf	1
symbol_rate	28	bslbf	1
}			

Semantics for the S2X PHY descriptor:

S2X_system_id: This 16-bit field uniquely identifies the S2X System within the `interactive_network_id` (see clause 6.2.2). The term is defined in ETSI EN 302 307-2 [30].

receiver_profiles: This field shall be encoded as defined in clause 6.4.5.5 of ETSI EN 300 468 [5].

S2X_mode: This field shall be encoded as defined in clause 6.4.5.5 of ETSI EN 300 468 [5].

NOTE: When time slicing is used, the `timeslice_number` can be inferred from the `PHY_stream_ID` (see clause 5.2.2.8).

polarization: This field shall be encoded as defined in clause 6.2.13.2 of ETSI EN 300 468 [5].

west_east_flag: This field shall be encoded as defined in clause 6.2.13.2 of ETSI EN 300 468 [5].

scrambling_sequence_selector: This field shall be encoded as defined in clause 6.2.13.3 of ETSI EN 300 468 [5].

scrambling_sequence_index: This field shall be encoded as defined in clause 6.2.13.3 of ETSI EN 300 468 [5].

frequency: This field shall be encoded as defined in clause 6.2.13.2 of ETSI EN 300 468 [5].

orbital_position: This field shall be encoded as defined in clause 6.2.13.2 of ETSI EN 300 468 [5].

roll_off: This field shall be encoded as defined in clause 6.2.13.2 of ETSI EN 300 468 [5].

symbol_rate: This field shall be encoded as defined in clause 6.2.13.2 of ETSI EN 300 468 [5].

5.2.2.12.2 Link association descriptor selector fields content

When the modulation system type in the link association descriptor indicates the use of DVB-S2X transmissions according to ETSI EN 302 307-2 [30] using channel bonding, the PHY stream indicated in the link association descriptor is the master channel, and the selector fields in the link association descriptor shall be coded as follows:

- a) the `selector_length_flag` field shall be set to one;

NOTE: This implies that the `selector_flags` field is not present, and `selector_length` field and subsequent `selector_byte` fields are present.

- b) the sequence of selector byte fields field shall be coded according to Table 27.

Table 27: Selector field for S2X channel bonding

Syntax	No. of Bits	Mnemonic	Applicable as of protocol version
<code>S2X_info() {</code>			
<code>if (S2X_mode == 3) {</code>			
<code>reserved_zero_future_use</code>	7	bslbf	1
<code>num_channel_bonds_minus_one</code>	1	uimsbf	1
<code>for (i=0;i<N;i++) {</code>			
<code>S2X_system_id</code>	16	uimsbf	1
<code>input_stream_identifier</code>	8	uimsbf	1
<code>}</code>			
<code>}</code>			
<code>}</code>			

Semantics of the S2X selector field:

num_channel_bonds_minus_one: This field shall be encoded as defined in clause 6.4.5.5 of ETSI EN 300 468 [5].

S2X_system_id: This field shall be coded according to clause 5.2.2.12.1, and it shall convey the S2X system ID of each non-master bonded channel.

input_stream_identifier: This field shall be encoded as defined in clause 6.2.13.3 of ETSI EN 300 468 [5], and it shall convey the input stream identifier of each non-master bonded channel.

NOTE: This field is used in calculating the PHY_stream_ID according to clause 5.2.2.8.

5.2.2.13 T2 PHY descriptor

The T2_PHY_descriptor shall be used to describe DVB-T2 transmissions according to ETSI EN 302 755 [13] within the interactive_network_id (see clause 6.2.2).

The following rules shall apply:

- Transmission of this descriptor is optional.
- More than one instance is allowed in a loop.
- The information from all instances in a loop shall be aggregated.

Table 28: T2 PHY descriptor

Syntax	No. of Bits	Mnemonic	Applicable as of protocol version
T2_PHY_descriptor() {			
descriptor_tag	8	uimsbf	0
descriptor_length	8	uimsbf	0
T2_system_id	16	uimsbf	0
SISO/MISO	2	bslbf	0
bandwidth	4	bslbf	0
reserved_future_use	2	bslbf	0
guard_interval	3	bslbf	0
transmission_mode	3	bslbf	0
other_frequency_flag	1	bslbf	0
tfs_flag	1	bslbf	0
common_clock_reference_id	4	uimsbf	0
reserved_for_future_use	4	bslbf	0
cell_loop_length	8	uimsbf	0
for (i=0;i<N,i++) {			
cell_id	16	uimsbf	0
if (tfs_flag == 1) {			
frequency_loop_length	8	uimsbf	0
for (i=0;i<N,i++) {			
centre_frequency	32	uimsbf	0
}			
}			
else {			
centre_frequency	32	uimsbf	0
}			
subcell_info_loop_length	8	uimsbf	0
for (i=0;i<N,i++) {			
cell_id_extension	8	uimsbf	0
transposer_frequency	32	uimsbf	0
}			
}			
}			

Semantics of the T2 PHY descriptor:

T2_system_id: This 16-bit field uniquely identifies the T2 System within the interactive_network_id (see clause 6.2.2). The term is defined in ETSI EN 302 755 [13].

SISO/MISO: This field shall be encoded as defined in clause 6.4.4.3 of ETSI EN 300 468 [5].

bandwidth: This field shall be encoded as defined in clause 6.4.4.3 of ETSI EN 300 468 [5].

guard_interval: This field shall be encoded as defined in clause 6.4.4.3 of ETSI EN 300 468 [5].

transmission_mode: This field shall be encoded as defined in clause 6.4.4.3 of ETSI EN 300 468 [5].

other_frequency_flag: This field shall be encoded as defined in clause 6.4.4.3 of ETSI EN 300 468 [5].

tfs_flag: This field shall be encoded as defined in clause 6.4.4.3 of ETSI EN 300 468 [5].

common_clock_reference_id: This 4-bit field indicates whether the signal in the current T2 multiplex or system is synchronized with other multiplexes or systems within the same network, and if synchronized it gives the ID of the clock reference it uses in common with other multiplexes or systems according to Table 29. This field will allow for fast zapping to a multiplex the receiver has previously visited.

Table 29: Common clock reference ID coding

common_clock_reference_id	Description
0	Not synchronized
1	Synchronized with clock ID 1
2	Synchronized with clock ID 2
3	Synchronized with clock ID 3
4	Synchronized with clock ID 4
5	Synchronized with clock ID 5
6	Synchronized with clock ID 6
7	Synchronized with clock ID 7
8 to 15	reserved for future use

cell_loop_length: This 8-bit field indicates the length in bytes of the following cell and subcell loops.

cell_id: This field shall be encoded as defined in clause 6.4.4.3 of ETSI EN 300 468 [5].

frequency_loop_length: This field shall be encoded as defined in clause 6.4.4.3 of ETSI EN 300 468 [5].

centre_frequency: This field shall be encoded as defined in clause 6.4.4.3 of ETSI EN 300 468 [5].

subcell_info_loop_length: This field shall be encoded as defined in clause 6.4.4.3 of ETSI EN 300 468 [5].

cell_id_extension: This field shall be encoded as defined in clause 6.4.4.3 of ETSI EN 300 468 [5].

transposer_frequency: This field shall be encoded as defined in clause 6.4.4.3 of ETSI EN 300 468 [5].

5.2.2.14 URI descriptor

This descriptor is used to list prominent URIs. By appropriate placement of this descriptor in the operational descriptor loop of the NCD records table, an association between the listed URIs and any streams, referenced by stream location descriptors in the same instance of the loop, can be established.

The following rules shall apply:

- a) Transmission of this descriptor is optional.
- b) More than one instance is allowed in a loop.
- c) The information from all instances in a loop shall be aggregated.

Table 30: URI descriptor

Syntax	No. of Bits	Mnemonic	Applicable as of protocol version
URI_descriptor() { descriptor_tag descriptor_length for (i=0;i<N,i++) { URI_length for (i=0;i<N,i++) { URI_byte } } }	8 8 16 8	uimsbf uimsbf uimsbf bslbf	0 0 0 0

Semantics of the URI descriptor:

URI_length: This 8-bit field indicates the length in bytes of the following URI.

URI_byte: This field conveys a URI and shall be encoded according to IETF RFC 3986 [16].

5.2.2.15 IP Multicast List descriptor

The IP_multicast_list_descriptor conveys a list of IPv4 multicasts carried in a physical link within the interactive_network_id. This descriptor also provides additional information for processing the UDP/IPv4 packets carrying the multicasts in the DVB-GSE layer. This descriptor only provides information on UDP/IPv4 multicasts.

The following rules shall apply:

- d) Transmission of this descriptor is optional.
- e) Only one instance with the same link_id is allowed in a loop.
- f) When this descriptor is used with the IPv6_multicast_list_descriptor, the multicast_stream_id shall be unique within the same physical link.

Table 31: IP Multicast List descriptor

Syntax	No. of Bits	Mnemonic	Applicable as of protocol version
IP_multicast_list_descriptor() { descriptor_tag descriptor_length num_multicasts for (i=0; i<num_multicasts-1; i++){ multicast_stream_id source_ipv4_address destination_ipv4_address source_port destination_port header_compression_flag reserved_for_future_use } }	8 8 16 16 32 32 16 16 1 7	uimsbf uimsbf uimsbf uimsbf uimsbf uimsbf uimsbf uimsbf bslbf bslbf	2 2 2 2 2 2 2 2 2 2

Semantics of the Multicast List descriptor:

num_multicasts: This 16-bit field indicates the number of multicasts following.

multicast_stream_id: This 16-bit field uniquely identifies the IP/UDP multicast stream within the physical link identified by the link_id.

source_ip_address: This 32-bit field indicates the source IPv4 address of the multicast carried in the physical link identified by the link_id.

destination_ip_address: This 32-bit field indicates the destination IPv4 address of the multicast carried in the physical link identified by the link_id.

source_port: This 16-bit field indicates the source UDP port number of the multicast carried in the physical link identified by the link_id.

destination_port: This 16-bit field indicates the destination UDP port number of the multicast carried in the physical link identified by the link_id.

header_compression_flag: This 1-bit Boolean field indicates whether header compression is applied to the multicast stream identified by multicast_stream_id. The value 0 (zero) indicates that the multicast stream is conveyed without header compression in the DVB-GSE layer. The value 1 (one) indicates that the header compression is applied to the multicast stream in the DVB-GSE layer. When the value of compressed_flag is equal to 1, there shall be an ROHC-U descriptor or ROHC-U_multicast_descriptor signalled.

reserved_for_future_use: This 7-bit field is reserved for future use, and all bits shall be set to zero.

5.2.2.16 IPv6 Multicast List descriptor

The IPv6_multicast_list_descriptor conveys a list of IPv4 multicasts carried in a physical link within the interactive_network_id. This descriptor also provides additional information for processing the UDP/IPv6 packets carrying the multicasts in the DVB-GSE layer. This descriptor only provides information on UDP/IPv6 multicasts.

The following rules shall apply:

- g) Transmission of this descriptor is optional.
- h) Only one instance with the same link_id is allowed in a loop.
- i) When this descriptor is used with the IP_multicast_list_descriptor, the multicast_stream_id shall be unique within the same physical link.

Table 32: IPv6 Multicast List descriptor

Syntax	No. of Bits	Mnemonic	Applicable as of protocol version
IPv6_multicast_list_descriptor() {			
descriptor_tag	8	uimsbf	2
descriptor_length	8	uimsbf	2
num_multicasts	16	uimsbf	2
for (i=0; i<num_multicasts-1; i++){			
multicast_stream_id	16	uimsbf	2
source_ipv6_address	128	uimsbf	2
destination_ipv6_address	128	uimsbf	2
source_port	16	uimsbf	2
destination_port	16	uimsbf	2
header_compression_flag	1	bslbf	2
reserved_for_future_use	7	bslbf	2
}			
}			

Semantics of the Multicast List deAscriptor:

num_multicasts: This 16-bit field indicates the number of multicasts following.

multicast_stream_id: This 16-bit field uniquely identifies the IP/UDP multicast stream within the physical link identified by the link_id.

source_ip_address: This 128-bit field indicates the source IPv6 address of the multicast carried in the physical link identified by the link_id.

destination_ip_address: This 128-bit field indicates the destination IPv6 address of the multicast carried in the physical link identified by the link_id.

source_port: This 16-bit field indicates the source UDP port number of the multicast carried in the physical link identified by the link_id.

destination_port: This 16-bit field indicates the destination UDP port number of the multicast carried in the physical link identified by the link_id.

header_compression_flag: This 1-bit Boolean field indicates whether header compression is applied to the multicast stream identified by multicast_stream_id. The value 0 (zero) indicates that the multicast stream is conveyed without header compression in the DVB-GSE layer. The value 1 (one) indicates that the header compression is applied to the multicast stream in the DVB-GSE layer. When the value of compressed_flag is equal to 1, there shall be an ROHC-U descriptor or ROHC-U_multicast_descriptor signalled.

reserved_for_future_use: This 7-bit field is reserved for future use, and all bits shall be set to zero.

5.2.2.17 RoHC-U Multicast descriptor

This ROHC-U_multicast_descriptor conveys configuration parameters for the Robust Header Compression [9] decompressor in Unidirectional mode of operation (ROHC-U, defined in section 4.4.1 of IETF RFC 3095 [10]) for GSE streams which use ROHC for IP as defined in ETSI TS 102 606-3 [2].

The following rules shall apply:

- j) Transmission of this descriptor is optional.
- k) Only one instance with the same link_id is allowed in a loop.

Table 33: ROHC-U Multicast descriptor

Syntax	No. of Bits	Mnemonic	Applicable as of protocol version
ROHC-U_multicast_descriptor() {			
descriptor_tag	8	uimsbf	2
descriptor_length	8	uimsbf	2
rohc_ch_id	16	uimsbf	2
max_CID	14	uimsbf	2
adaptation_flag	1	bslbf	2
reserved	1		
num_rohc_flow	16	uimsbf	2
for (i=0; i<num_rohc_flow; i++){			
context_id	8 or 16	bslbf	2
context_profile	8	uimsbf	2
multicast_stream_id	16	uimsbf	2
if (adaptation_flag==1){			
static_chain_length	8	uimsbf	2
for (i=0;i<N;i++){			
static_chain_byte	8	bslbf	2
}			
}			
}			

Semantics of the ROHC-U multicast descriptor:

rohc_ch_id: This 16-bit field indicates the ROHC channel corresponding to this descriptor. The ROHC channel can be mapped to physical layer stream. If single ROHC channel is configured in the physical link, the rohc_ch_id can be the same value with link_id.

max_CID: This 14-bit field indicates the maximum value of context id (CID) to be used corresponding to this ROHC channel. The max_CID field shall not have a value greater than 16 383.

adaptation_flag: This 1-bit Boolean field indicates whether the separated transmission of static chain byte is performed by adaptation module in this ROHC channel. The value 0 (zero) indicates that no additional operation can be performed on the original ROHC packet stream by the Adaptation module. The value 1 (one) indicates that static chain byte is extracted by Adaptation module and transmitted as a part of the LLC data.

num_rohc_flow: This 16-bit field indicates the number of ROHC compressed packet flow following.

context_id: This 8-bit or 16-bit field indicates the context id (CID) of the compressed IP stream. It shall be encoded as defined in clause 5.1.3 of IETF RFC 3095 [10].

NOTE: Clause 5.1.3 of IETF RFC 3095 [10] defines that ROHC uses either a small or a large CID, and that it is encoded using the self-describing variable-length encoding (defined in clause 4.5.6 of IETF RFC 3095 [10]) with the field size limited to two octets.

context_profile: This 8-bit field indicates the range of protocols used to compress the stream. It shall convey the eight least significant bits of the ROHC profile identifier defined in clause 4.1.1 of ETSI TS 102 606-3 [2].

multicast_stream_id: This 16-bit field uniquely identifies the IP/UDP multicast stream within the physical link identified by the link_id.

static_chain_length: This 8-bit field indicates the length of the static chain byte sequence.

static_chain_byte: This field conveys the static information used to initialize the ROHC-U decompressor. The size and structure of this field depend on the context profile.

5.2.2.18 S2Xv2 PHY descriptor

5.2.2.18.1 Descriptor syntax and semantics

The S2Xv2_PHY_descriptor shall be used to describe DVB-S2X transmissions according to [30 Annex E] within the interactive_network_id (see clause 6.2.2).

The following rules shall apply:

- a) Transmission of this descriptor is optional.
- b) More than one instance is allowed in a loop.
- c) The information from all instances in a loop shall be aggregated.

In most cases (channel bond is set to 0) the S2Xv2 system is described by a single S2Xv2_PHY_descriptor, with the exception when bonded channels are used. The S2Xv2_system_id is concatenation of the S2X_system_id and the S2Xv2_selector field.

When channel bonding is used, one S2Xv2_PHY_descriptor describes the master (channel bond is set to 1) and one or two S2Xv2_PHY_descriptor(s) describe(s) the secondary (channel bond is set to 2).

The S2Xv2_PHY_descriptor shall be coded according to table 34. It describes the modulation parameters used for DVB-S2X transmissions. The GSE-LLC records as are required by the present document, may need to be carried in some or in all of the bonded channels.

Table 34: S2Xv2 PHY descriptor

Syntax	Number of bits	Identifier	Protocol Version
S2Xv2_PHY_descriptor() {			
descriptor_tag	8	uimsbf	2
descriptor_length	8	uimsbf	2
S2Xv2_system_id	16	uimsbf	2
S2Xv2_system_selector	16	uimsbf	2
receiver_profiles	5	bslbf	2
TS_GS_S2X_mode	2	bslbf	2
reserved_zero_future_use	1	bslbf	2
S2Xv2_mode	4	uimsbf	2
roll_off	3	bslbf	2
NCR_reference	1	bslbf	2
NCR_version	1	bsb1f	2
channel_bond	2	bsb1f	2
polarization	2	bsb1f	2
if (S2Xv2_mode==1 or S2Xv2_mode==2) {			
scrambling_sequence_selector	1	bsb1f	2
} else {			
reserved_zero_future_use	1	bsb1f	2
}			

Syntax	Number of bits	Identifier	Protocol Version
reserved_zero_future_use	2	bslbf	2
satellite_id	24	uimsbf	2
frequency	32	bslbf	2
symbol_rate	32	bslbf	2
if (S2Xv2_mode==1 or S2Xv2_mode==2) {			
if (scrambling_sequence_selector == 1) {			
reserved_zero_future_use	6	bslbf	2
scrambling_sequence_index	18	uimsbf	2
}			
}			
if (S2Xv2_mode==2 or S2Xv2_mode==5) {			
timeslice_number	8	uimsbf	2
}			
if (S2Xv2_mode==4 or S2Xv2_mode==5) {			
SOSF_WH_sequence_number	8	uimsbf	2
SFFI_selector	1	bslbf	2
beam_hopping_time_plan_selector	1	bslbf	2
reserved_zero_future_use	2	bslbf	2
reference_scrambling_index	20	uimsbf	2
if (SFFI_selector==1) {			
SFFI	4	bslf	2
} else {			
reserved_zero_future_use	4	bslbf	2
}			
payload_scrambling_index	20	uimsbf	2
if (beam_hopping_time_plan_selector==1) {			
beamhopping_time_plan_id	32	uimsbf	2
}			
superframe_pilots_WH_sequence_number	5	uimsbf	2
postamble_PLI	2	bslf	2
reserved_zero_future_use	1	uimsbf	2
}			
for (i=0;i<N;i++) {			
reserved_zero_future_use	8	bslbf	2
}			
}			

S2Xv2_system_id: This 16-bit field identifies the modulation system within the interactive network

S2X_system_selector: This 16-bit field, together with the S2X_system_id uniquely identifies the S2Xv2 system within the interactive network.

Note: The 32-bit field composed of the S2X_system_id as the most significant byte and the S2X_system_selector as the least significant byte are equivalent to the **delivery_system_id:** As specified in Table 144b: S2Xv2 satellite delivery system info of ETSI EN 300 468 [5] introduced in V1.18.1.

S2Xv2_mode: As specified in Table 144b: S2Xv2 satellite delivery system info of ETSI EN 300 468 [5] introduced in V1.18.1.

roll_off: This 3-bit field shall be coded according to clause 6.4.6.5 of ETSI EN 300 468 [5].

NCR_reference: As specified in Table 144b: S2Xv2 satellite delivery system info of ETSI EN 300 468 [5] introduced in V1.19.1 Vx.x.x.

NCR_version: As specified in Table 144b: S2Xv2 satellite delivery system info of ETSI EN 300 468 [5] introduced in V1.18.1.

channel_bond: As specified in Table 144b: S2Xv2 satellite delivery system info of ETSI EN 300 468 [5] introduced in V1.18.1.

polarization: This 2-bit field shall be coded according to clause 6.2.13.3 of ETSI EN 300 468 [5].

scrambling_sequence_selector: This 1-bit field shall be coded according to clause 6.2.13.3 of ETSI EN 300 468 [5].

TS_GS_S2X_mode: This 2-bit field shall be coded according to clause 6.4.6.5.2 of ETSI EN 300 468 [5].

receiver_profiles: This 5-bit field shall be coded according to clause 6.4.6.5.2 of ETSI EN 300 468 [5].

satellite_id: As specified in Table 144b: S2Xv2 satellite delivery system info of ETSI EN 300 468 [5] introduced in V1.18.1.

frequency: This 32-bit field shall be coded according to clause 6.2.13.3 of ETSI EN 300 468 [5].

symbol_rate: As specified in Table 144b: S2Xv2 satellite delivery system info of ETSI EN 300 468 [5] introduced in V1.18.1.

scrambling_sequence_index: This 18-bit field shall be coded according to clause 6.2.13.3 of ETSI EN 300 468 [5].

timeslice_number: This 8-bit field shall be coded according to clause 6.2.13.3 of ETSI EN 300 468 [5].

NOTE 3: For superframes of a superframe format that does not support time slicing, this timeslice_number is not applicable.

SOSF_WH_sequence_number: As specified in Table 144b: S2Xv2 satellite delivery system info of ETSI EN 300 468 [5] introduced in V1.18.1.

SFFI_selector: As specified in Table 144b: S2Xv2 satellite delivery system info of ETSI EN 300 468 [5] introduced in V1.18.1.

beam_hopping_time_plan_selector: As specified in Table 144b: S2Xv2 satellite delivery system info of ETSI EN 300 468 [5] introduced in V1.18.1.

reference_scrambling_index: As specified in Table 144b: S2Xv2 satellite delivery system info of ETSI EN 300 468 [5] introduced in V1.18.1.

SFFI: As specified in Table 144b: S2Xv2 satellite delivery system info of ETSI EN 300 468 [5] introduced in V1.18.1.

payload_scrambling_index: As specified in Table 144b: S2Xv2 satellite delivery system info of ETSI EN 300 468 [5] introduced in V1.18.1.

beamhopping_time_plan_id: As specified in Table 144b: S2Xv2 satellite delivery system info of ETSI EN 300 468 [5] introduced in V1.18.1.

superframe_pilots_WH_sequence_number: As specified in Table 144b: S2Xv2 satellite delivery system info of ETSI EN 300 468 [5] introduced in V1.18.1.

Superframe_PLI: As specified in Table 144b: S2Xv2 satellite delivery system info of ETSI EN 300 468 [5] introduced in V1.19.1.

5.2.2.18.2 Link association descriptor selector fields content

When the modulation system type in the link association descriptor indicates the use of DVB-S2Xv2 transmissions according to ETSI EN 302 307-2 [Annex E of 30], the selector fields in the link association descriptor shall be coded as follows:

- a) The selector_flags field is not present, and selector_length field and subsequent selector_byte fields are present.
- b) the selector_length_flag field shall be set to one;
- c) When using channel bonding, the PHY stream indicated in the link association descriptor is the master channel;
- d) The sequence of selector byte fields field shall be coded according to Table 35.

Table 35: Selector field for S2Xv2 System

	No. of Bits	Mnemonic	Applicable as of protocol version
S2Xv2_info() {			
S2Xv2_system_selector	16	uimsbf	2
if (channel_bond=1) {			
reserved_zero_future_use	7	bslbf	2
num_channel_bonds_minus_one	1	uimsbf	2
for (i=0;i<N;i++) {			
S2Xv2_system_id	16	uimsbf	2
S2Xv2_system_selector	16	uimsbf	2
input_stream_identifier	8	uimsbf	2
}			
}			
}			

S2Xv2_system_selector: As defined in section 5.2.18.1 above.

num_channel_bonds_minus_one: As defined in in clause 6.4.5.5 of ETSI EN 300 468 [5].

S2X_system_id: As defined in section 5.2.18.1 above and it shall convey the S2X system ID of each non-master bonded channel.

S2Xv2_system_selector: As defined in section 5.2.18.1 above and it shall convey the S2X system ID of each non-master bonded channel.

5.2.3 Rules for future extensibility of descriptors

The rules defined in this clause enable descriptors to be extended in a forwards and backwards compatible way. This means that:

- an old parser implementation will still be able to correctly process a descriptor which was encoded according to a newer syntax;
- a new parser implementation will still be able to correctly process a descriptor which was encoded according to an older syntax.

When **extending the syntax of descriptors defined in the present document and when adding new descriptors to the present document**, the following rules shall apply:

- To parse the known fields of a descriptor, it shall not be required to know the value of the descriptor_length field.

NOTE 1: This means that variable length fields and elements will need to be preceded by length fields as appropriate.

- New fields shall always be appended to the end of the descriptor.
- Fields from previous versions shall never be removed from a descriptor. When a field from a prior version is to be replaced by a new one, later versions of the syntax may define that the contents of the old field shall be ignored.

NOTE 2: When encoding a descriptor with such a replaced field, operators should ensure that the old field is still set to a meaningful value to enable old parsers to correctly process the descriptor.

- When adding new fields to a descriptor, default values should be defined for them as appropriate.

When **parsing descriptors defined in the present document**, the following rules shall apply:

- Parsers shall never assume that any descriptor has a fixed length, and shall always take the value of the descriptor_length field into account.

- b) Parsers implementing version 1.2.1 or later of the present document shall use the protocol version conveyed in the LLC index to determine whether the data has been encoded according to the same, a prior, or a later version of the present document than the parser implementation.

NOTE: If the parser and data versions do not match, there may be missing or unknown data fields. The following rules define how to handle these.

- c) Parsers shall ignore any unknown data fields at the end of a descriptor.
- d) The presence of unknown data fields shall not result in the descriptor being ignored, but the values decoded from the known fields shall be returned as if the descriptor had fully met the parser's expectations.
- e) The absence of known data fields shall not result in the descriptor being ignored, but the values decoded from the present fields shall be returned as if the descriptor had fully met the parser's expectations, and default values shall be returned for the absent fields.

6 Transport in GSE Packets

6.0 Carriage in extension headers

All LLC data as defined in clause 5.1 shall be encoded in the extension header bytes as defined in part 1 [1].

All LLC index and table data as defined in clause 5.1 shall be carried in `gse_table_structure()` containers as defined in clause 6.4.3.1.1 of ETSI EN 301 545-2 [4] for un-addressed lower layer signalling transport in GSE packets. This implies that the `gse_table_structure()` containers are carried in the extension header field of GSE packets. For the use of these containers, the rules in clause 6 shall be followed.

NOTE: For a complete example of the use of the `gse_table_structure()`, see Figure A.1.

6.1 GSE Header Fields

6.1.1 Start Indicator and End Indicator

These fields shall be set according to ETSI TS 102 606-1 [1]. This implies that a `gse_section_structure()` container may be larger than a single GSE packet. If fragmentation is used, all fragmentation rules set forth in ETSI TS 102 606-1 [1] shall be applicable.

6.1.2 Label Type Indicator

GSE packets carrying LLC information shall omit any label, and hence set the `Label_Type_Indicator` field to the value "10", indicating the absence of the label field as defined in ETSI TS 102 606-1 [1].

6.1.3 Protocol Type

The header of every GSE packet that contains the start of an encapsulated PDU, contains the 16-bit `Protocol_Type` field to indicate the type of payload carried in the PDU, or the presence of a Next-Header (see clause 4.2.1 of ETSI TS 102 606-1 [1]). Either the `Protocol_Type` field, or the Next-Header field of GSE packets carrying LLC information shall use the `Protocol_Type` value allocated by [17] to "DVB-GSE_LLC". Which field is used will depend on whether any optional extension headers precede the LLC mandatory extension header; for more information see clause 6.1.4.

NOTE: The allocated value can be looked up at <https://www.iana.org/assignments/ule-next-headers/ule-next-headers.xhtml>.

6.1.4 Extension Header Byte

Since a protocol type value less than 0x0600 (i.e. outside the standard EtherType range) is used for LLC information, all LLC data is carried in the extension header field of the GSE packets. All LLC data shall be carried in

`gse_table_structure()` containers as defined in clause 6.4.3.1.1 of ETSI EN 301 545-2 [4] for un-addressed lower layer signalling transport in GSE packets. Since the value for the `Protocol_Type` is less than 256, the LLC data is carried as a mandatory extension header.

NOTE 1: For an introduction to the extension header mechanism, please see clause 6.1.2 of ETSI TS 102 771 [i.1].

NOTE 2: For a complete example of the use of the `gse_table_structure()`, see Figure A.1.

For the use of extension headers in GSE packets carrying LLC data, the following rules shall apply:

- a) The mandatory extension header carrying LLC data may be preceded by optional extension headers (see clause 5 of IETF RFC 4326 [28]).
- b) No other mandatory extension headers shall be present.

NOTE 3: This also implies that only one mandatory extension header carrying LLC data may be present.

- c) The mandatory extension header carrying LLC data shall always begin with the index structure as is defined in clause 5.1.
- d) The index structure shall list all LLC tables following it.
- e) There shall only be only one index structure in the LLC mandatory extension header.
- f) The index structure may be followed by other LLC records as are defined in clause 5.1.

6.1.5 PDU Data Byte

The `PDU_data_byte` field shall not be present in GSE packets carrying LLC information.

6.2 GSE Table Structure Fields

6.2.0 General

The syntax and semantics of the `gse_table_structure()` are defined in clause 6.4.3.1.1 of ETSI EN 301 545-2 [4].

NOTE: For a complete example of the use of the `gse_table_structure()`, see Figure A.1.

6.2.1 Table ID

Since the present document uses the same method for conveying LLC as ETSI EN 301 545-2 [4], the value of the `table_id` field needs to be coordinated with ETSI EN 301 545-2 [4]. Table 6-1 in ETSI EN 301 545-2 [4] allocates the values for various uses, and reserves the values given below for the present document. For the purposes of the present document, the following rules shall apply:

- a) index data shall be carried in `gse_table_structure()` containers using a `table_id` of 0xB3;
- b) LCD shall be carried in `gse_table_structure()` containers using a `table_id` of 0xB4;
- c) NCD shall be carried in `gse_table_structure()` containers using a `table_id` of 0xB5.

6.2.2 Interactive Network ID

This 16-bit field shall be set to the same value as the `network_id` [5] and [6].

6.2.3 Version Number and Current/Next Indicator

These fields shall be set according to ETSI EN 301 545-2 [4].

6.3 Combining Streams From Different Interactive Networks

When streams originating from different interactive networks are to be combined of a single service platform, the LLC data from these interactive networks will also need to be combined.

7 Deployment Profiles

7.1 Bi-directional interface emulation

In deployments where enhanced interactivity is desired, the uni-directional broadcast link may be complemented by an additional interaction channel. An example use-case employing an Internet service provided by an ISP over a DSL connection is shown in Figure 8.

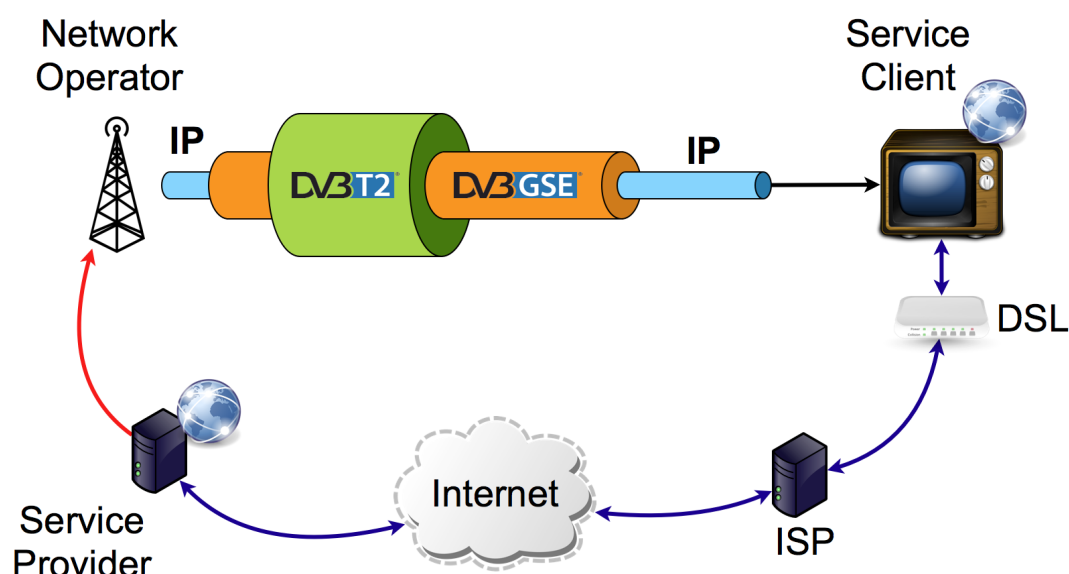

Figure 8: Example bi-directional use-case

In this scenario, the service client sends requests to the service provider via the interaction channel. The service provider may then decide whether to send the response back to the client through the broadcast channel, or the interaction channel.

To make service client implementations independent of the specifics of the interaction channel, those network interfaces on the service client that represent broadcast channels carrying such enhanced interactivity services, shall use the UDLR mechanism defined in IETF RFC 3077 [11] to emulate a bi-directional channel.

7.2 Generic network service profile

In this profile, the GSE link layer is used to provide a generic network service to receivers. The information in the GSE packets carrying LLC is only used to configure network interfaces on the receiver. This is similar to an Internet service provided by an ISP over a DSL connection, or by a mobile operator over a 3G or LTE connection. This profile allows more than one applications to coexist, and to be used on top of the network service.

In the Generic Network Service Profile, the following rules shall apply:

- a) The application system descriptor shall not be transmitted.
- b) The URI descriptor shall not be transmitted.

Since no additional information about any applications in use on top of the network service is available, receivers shall use service discovery and selection mechanisms provided on top of the network service. This may for example involve

joining well-known multicast groups in the case of an IP network service. The presence of well-known multicast groups can also be inferred from information in NCD records tables (see clause 5.1.3).

7.3 Application system profile

7.3.0 General use of the application system profile

In this profile, the GSE link layer is used to provide a network service to a predominant application used on top of it.

In the Application System Profile, the following rules shall apply:

- a) The application system descriptor shall always be transmitted.

Since an application system may provide the same, or similar information about network links as defined in the present document, the information conveyed in the GSE LLC data may be restricted to a minimum. This minimum set of GSE LLC data may only describe the entry points to the service discovery information provided by the application system.

7.3.1 OMA BCAST system profile

In case the OMA BCAST system is used as application on the top of IP layer, the application system descriptor shall be present, and the `application_system_id` field shall be set according to ETSI TS 101 162 [6].

The L2 signalling information LCD and NCD elements are transmitted in the Service Guide Delivery Descriptor of the announcement channel as defined in [29].

NOTE: Here, LCD and NCD refer to the data structures defined in [29] and transmitted as part of the SGDD in OMA BCAST, and not to the tables of the same name defined in the present document.

The GSE LLC data shall at least describe the entry point of the bootstrap channel by conveying an appropriate application system descriptor. This entry point is transmitted in the `OMA_BCAST_info` of the application system descriptor. This entry point identifies the PLP used for the transmission of the bootstrap session. For an efficient filtering in the receiver, the `OMA_BCAST_info` can provide versioning information to notify receivers of any updates. All other LLC tables and descriptors are optional in this profile.

As defined in [29], the bootstrap session containing the bootstrap descriptors will be retrieved in the PLP defined in the `OMA_BCAST_info`, on a specific FLUTE channel as defined in [29].

The bootstrap descriptors, the `ESGProviderDiscovery` Descriptor and `ESGAccessDescriptor` that are used within the bootstrap session allow the discovery of the provider of the service guide and the access to the service guide. The session accessible with `ESGAccessDescriptor` is a Service Guide Announcement Channel containing the Service Guide Delivery Descriptor where the LCD and NCD elements are transmitted. For more details, see [29].

Annex A (informative): Examples

A.1 Carriage of LLC data in extension headers

The example given in Figure A.1 demonstrates how LLC data structures - in this case an index structure, an LCD table, and an NCD table - are carried as a mandatory extension header in a GSE packet. As defined in clause 6.1.4, GSE packets conveying LLC data do not carry a regular payload in addition to extension headers. GSE parsers which do not implement LLC according to the present document, will skip the entire LLC mandatory extension header.

Syntax	No. of Bits	Value	Byte Offset	Remarks
GSE_Packet() {				
Start_Indicator	1	(1) ₂	0	PDU starts in this packet
End_Indicator	1	(1) ₂	0	PDU ends in this packet
Label_Type_Indicator	2	(10) ₂	0	broadcast (i.e. no label)
GSE_Length	12	807	0 to 1	number of bytes following
Protocol_Type	16	0x0087	2 to 3	DVB-GSE_LLC mand. ext. header
if (Protocol_Type < 1536) {				
gse_table_structure() {				
table_id	8	0xB3	4	LLC index
interactive_network_id	16	0x1234	5 to 6	
reserved	2	(11) ₂	7	
version_number	5	3	7	
current_next_indicator	1	(1) ₂	7	current
for (i=0; i < N; i++) {				
LLC_index() {				
num_table_entries	8	2	8	two entries in the index
for (i=0; i<N;i++) {				
table_id	8	0xB4	9	first entry: LCD
reserved	2	(11) ₂	10	
version	5	5	10	
current_next_indicator	1	(1) ₂	10	
offset	32	0x0000 0000	11 to 14	offset always zero for 1st entry
table_id	8	0xB5	15	second entry: NCD
reserved	2	(11) ₂	16	
version	5	6	16	
current_next_indicator	1	(1) ₂	16	
offset	32	0x0000 0011	17 to 20	offset = 17
}				
} /* LLC_index() */				
} /* gse_table_structure() */				
gse_table_structure() {				
table_id	8	0xB4	21	LCD table
interactive_network_id	16	0x1234	22 to 23	
reserved	2	(11) ₂	24	
version_number	5	5	24	
current_next_indicator	1	(1) ₂	24	current
for (i=0; i < N; i++) {				
/* 13 bytes table body */	104		25 to 37	
}				
} /* gse_table_structure() */				
gse_table_structure() {				
table_id	8	0xB5	38	NCD table
interactive_network_id	16	0x1234	39 to 40	
reserved	2	(11) ₂	41	
version_number	5	6	41	
current_next_indicator	1	(1) ₂	41	current
for (i=0; i < N; i++) {				
/* 768 bytes table body */	6144		42 to 809	
}				
} /* gse_table_structure() */				
} /* GSE extension header */				
} /* GSE_Packet() */				

Figure A.1: Example GSE packet with LLC data carried in the extension header

A.2 Finding the size of the last table

As explained in clause 5.1.1.1, the end of the last table cannot be inferred from the index alone, but needs to be calculated by taking the total size of the LLC data into account. The index structure hints to the sizes of all tables, except for the last. The Total_Length field for cases where fragmentation occurs, or the GSE_Length field for cases where fragmentation does not occur, on the other hand indicate the overall size of the LLC data. The length (and therefore the end) of the last table can thus be inferred from the difference between the beginning of the last table, and the overall LLC data size. Of course the size of the index itself, and the Protocol_Type field will need to be taken into account for this calculation.

In the hypothetical buffer used in clause 5.1.1.1, the end of the last table can be calculated as:

$$\text{sizeof}(\text{table}_{\text{last}}) = \text{TotalLength} - \text{sizeof}(\text{LLC}_{\text{index}}) - [\text{offset}(\text{table}_{\text{last}}) + 1]$$

NOTE: The above equation applies when fragmentation occurs. In case fragmentation does not occur, Total_Length can be replaced with GSE_Length.

In the example in Figure A.1, the GSE_Length field has the value 807, the offset of the last table in the GSE packet is 38. With these figures the size of the last table computes to:

$$\text{sizeof}(\text{table}_1) = 807 - 17 - [17 + 1] = 790 - 18 = 772$$

Which equals the 768 bytes table body, plus the four bytes of gse_table_structure() header.

A.3 Underlying data model

The data model underlying the syntax and semantics of the LLC data defined in the present document is shown in Figure A.2 as an entity-relationship (ER) model, and the mapping to the LCD and NCD tables is hinted.

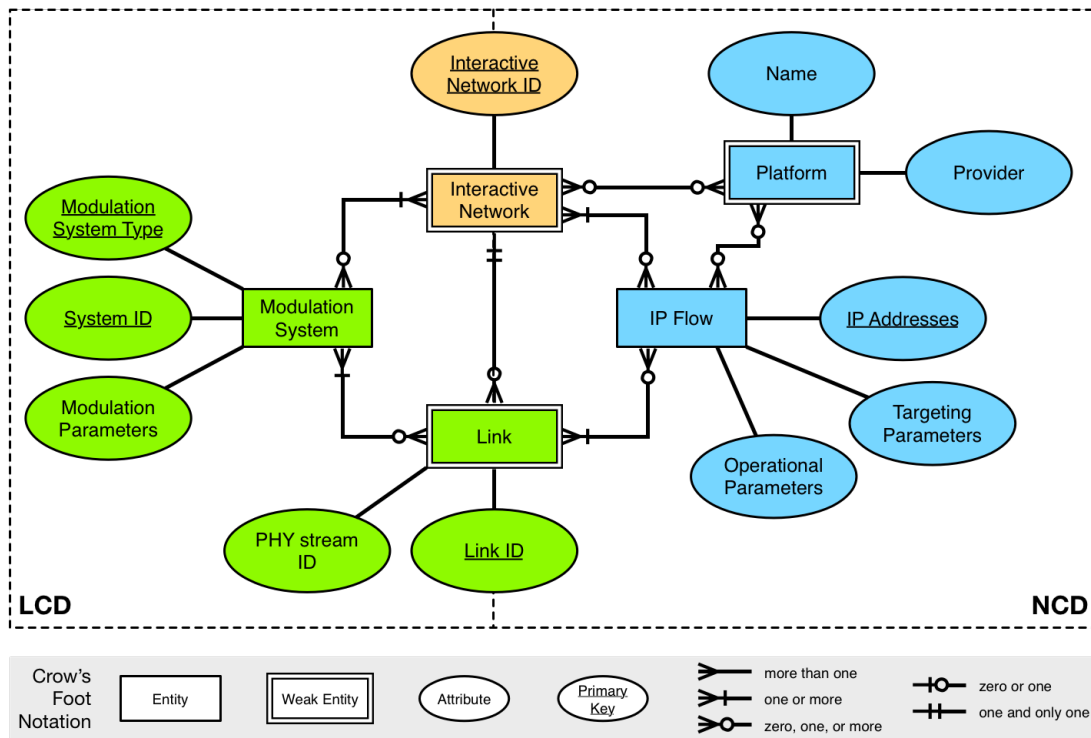

Figure A.2: Data model of the LLC information

The entities of this model are:

- **Modulation System:** This entity represents a modulation system at the RF level, characterized by its type (for example DVB-T2), and its system id (for example the T2_system_id). It is further described by a set of modulation parameters (frequencies, etc.).
- **Link:** This entity represents a virtual network interface on the receiver. It is hence associated with one or more IP Flows. Since the same data stream may be available on more than one modulation system stream, a Link may appear in more than one instance, each of which is associated with exactly one modulation system stream characterized by modulation system type, modulation system ID, and PHY stream ID (for example a specific PLP in a particular DVB-T2 system). As the same data is delivered on all instances of a Link, receivers may freely switch between the instances of a particular Link, however bearing in mind that different routes may imply different propagation delays being applied to the data.

- **IP Flow:** This entity represents the data stream delivered over a given Link. Since the same data may be available from various locations, an IP Flow can be associated with one or more Links. An IP Flow is further described by targeting parameters (for example describing IP source and/or destination addresses found in the flow), and operational parameters (for example ROHC-U header compression parameters). The connection between IP Flows and Links is made by the Link ID.
- **Platform:** This entity represents a collection of IP Flows provided by an operator. An operator may operate one or more IP Flows.

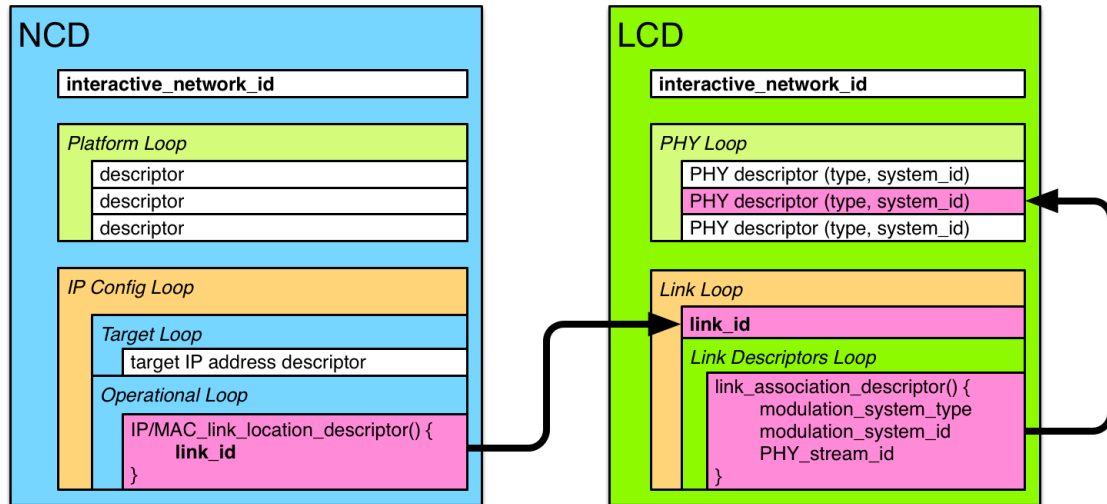

Figure A.3: Mapping to LLC tables and lookup path

Figure A.3 shows how the above concepts have been mapped to the LCD and NCD tables, and how lookups can be performed. Note that due to the one-to-many relationships in the data model above, unambiguous lookups can only be done in one direction. This design was chosen based on the assumption that receivers would start from service discovery information they have acquired above the IP layer. Such information would for example indicate that the elements comprising a certain service, are available on specific multicast group addresses. To acquire the service, a receiver would then need to determine which PHY stream in which modulation system carries data for those multicast addresses, and what interface configuration needs to be applied (for instance whether ROHC-U is used).

To implement this lookup sequence, the operational loop in the NCD features the IP/MAC link location descriptor, which specifies a Link ID, on which the relevant data is available. The link loop in the LCD in turn lists all the links, and it can hence be scanned for the Link ID in question. From the modulation system streams listed in under this Link ID, the receiver can infer the modulation parameters, and the PHY stream ID.

Reverse lookups are of course possible, but will most likely yield lists of entities. Hence additional information may be needed to select one of the options from the lookup results.

Figure A.3 also shows that the LCD and NCD are labelled by an interactive network ID. It identifies the RF network which carries the streams, and is independent of the Platform described above. This is to accommodate the fact that often the operator of the RF infrastructure, and the operator of the services carried on it are different entities.

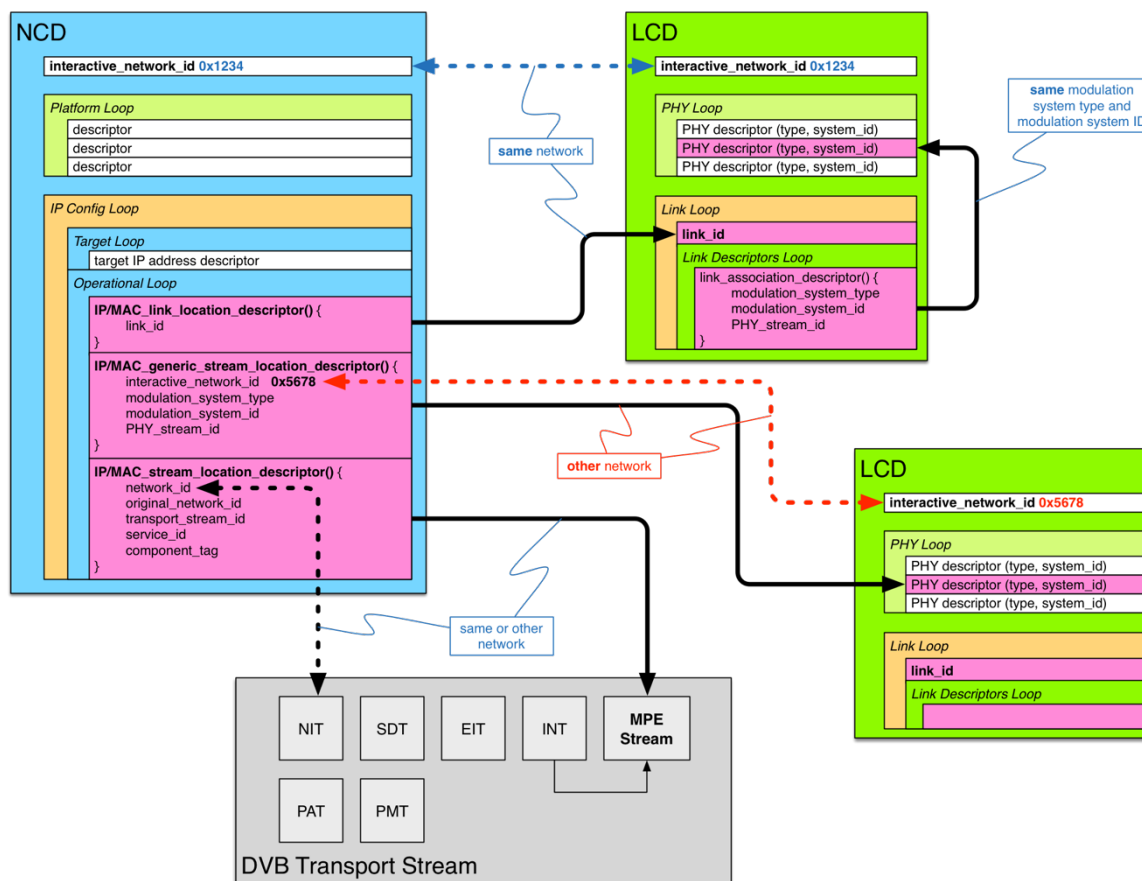

Figure A.4: Mapping to LLC tables across networks, and to Transport Stream resources

Figure A.4 extends from the example in Figure A.3 by also showing how Links in other interactive networks, and IP Flows carried in DVB Transport Streams using MPE can be referenced.

To reference a Link in another interactive network, an IP/MAC generic stream location descriptor is carried in an operational loop of an NCD. It indicates an interactive network ID which is different from the interactive network ID of the NCD itself. The other parameters in the IP/MAC generic stream location descriptor are the modulation system type, modulation system ID, and PHY stream ID of the Link being referenced. If an LCD from the other interactive network, with a matching interactive network ID, can be acquired, a lookup for a PHY descriptor of matching modulation system type and modulation system ID can be performed.

NOTE: The IP/MAC generic stream location descriptor can also be conveyed in DVB Service Information as defined in ETSI EN 301 192 [3] in DVB Transport Streams. It is thus also possible to reference Links carried using DVB-GSE from DVB Transport Streams.

Conceptually, it would be sufficient to only convey the interactive network ID, and the link ID in the IP/MAC generic stream location descriptor to unambiguously reference a Link in another interactive network. By instead conveying the modulation system type and modulation system ID, two operational advantages are achieved:

- The need for coordination of link ID values between different networks is removed. When the operator of an interactive network decides to change the link ID assigned to a specific Link, the operators of all other networks which carry IP/MAC generic stream location descriptors referencing that Link would need to learn about the update. Those other operators would then in turn need to update all IP/MAC generic stream location descriptors referencing that Link. The information about link ID updates in other interactive networks can either be obtained by constantly.

- Dereferencing the pointer is simplified. If a link ID were conveyed in the IP/MAC generic stream location descriptor, an LCD for the other interactive network would either need to have been received previously, or a service scan would need to be performed before the modulation parameters of the referenced Link can be known. If any data - not just an LCD - from the referenced modulation system has been received before (e.g. a DVB Transport Stream on another PHY stream), all modulation parameters are known, and the Link can be acquired without any further LCD processing. This also applies when the IP/MAC generic stream location descriptor is carried in a DVB Transport Stream.

To reference an IP Flow carried in DVB Transport Streams using MPE, an IP/MAC stream location descriptor is carried in an operational loop of an NCD. It indicates a network ID which is different from the interactive network ID of the NCD itself. The other parameters in the IP/MAC stream location descriptor are the original network ID, the transport stream ID, the service ID, and the component tag of the Link being referenced. If a Network Information Table (NIT) from the other network, with a matching network ID, can be acquired, a lookup for a delivery system descriptor associated with matching transport stream ID and original network ID can be performed. This delivery system descriptor will contain the modulation system parameters, which - together with the service ID and component tag - allow to acquire the Link. An IP/MAC generic stream location descriptor can also be carried in the INT in the DVB Transport Stream, allowing to reference IP Flows carried using GSE from DVB Transport Streams.

A.4 Use of Link Control Data

A.4.1 Carriage of Links on different physical layers

Figure A.5 shows an example of an LCD which describes two Links. One is delivered on DVB-T2 only, whereas the other Link is delivered on both, DVB-T2 and DVB-S2. This means that for the latter Link, the same IP Flow can be received on DVB-T2 and DVB-S2. This may for instance be useful to address a diverse receiver population.

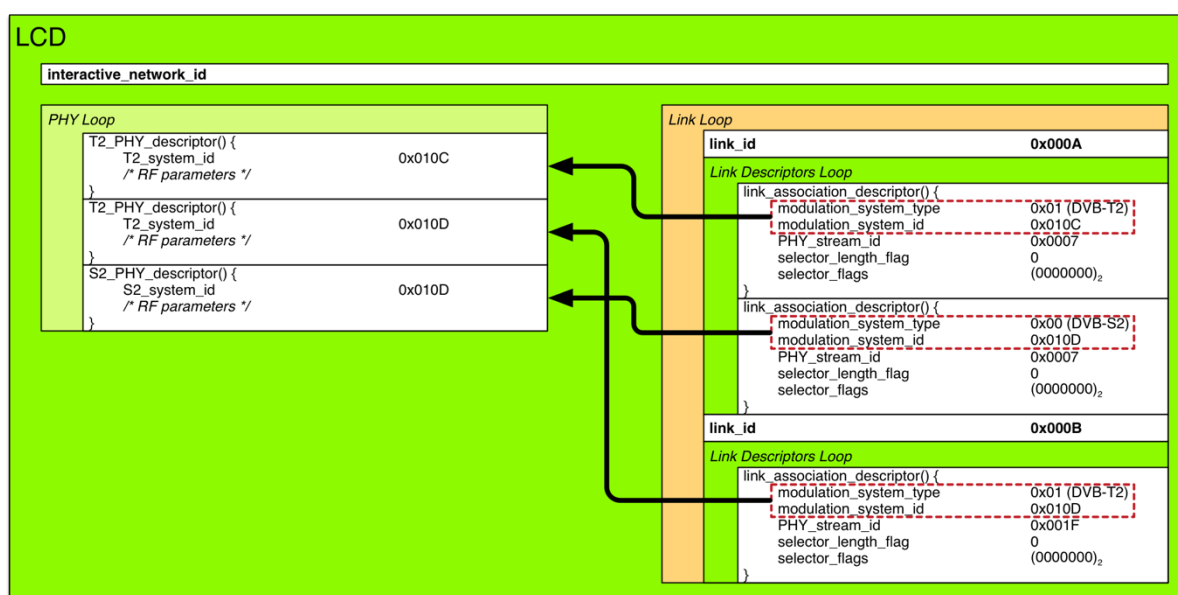

Figure A.5: Example of carriage of Links on different physical layers

When an IP/MAC link location descriptor in an operational loop of an NCD for this interactive network (indicated by a matching interactive network ID) references a Link with link ID 0x000B, a receiver will search the Link loop of the LCD for that link ID. In this case, it would find a Link with link ID 0x000B in the LCD (lower right part of Figure A.5). The link association descriptor for this Link indicates that the IP Flow for it can be received on DVB-T2 from the T2 system ID 0x010D and with the PLP ID 0x1F (DVB-T2 PLP IDs are 8-bit values and are hence encoded in the lower order byte of the PHY_stream_id field). The receiver will then search the PHY loop of the same LCD for a T2_PHY_descriptor indicating a T2 system ID of 0x010D. IN this example, it finds a T2_PHY_descriptor with this T2 system ID (second entry on the PHY loop in Figure A.5). The receiver will infer the necessary DVB-T2 modulation system parameters from the descriptor, tune to the DVB-T2 modulation system, and start receiving data for PLP 0x1F.

When an IP/MAC link location descriptor in an operational loop of an NCD for this interactive network references a Link with link ID 0x000A, a receiver will search the Link loop of the LCD for this link ID as described in the preceding paragraph. For this Link it will find two link association descriptors instead of one as for the link 0x000B. This means that his Link can be received from either of the two locations. In this case, the Link can be received from a DVB-T2 system, and from a DVB-S2 system. For both systems, the further lookup of the RF parameters, and acquitting of the IP Flow proceeds as described in the preceding paragraph. For each location from which a Link is available, a link association descriptor is inserted into the Link descriptors loop. These descriptors can refer to modulation systems of different types, of the same type, or a mixture of both. This allows for a flexible aggregation of Links from diverse sources, and yet at the same time allows to describe such Link collections with a single LCD (which hence may also be centrally generated).

In any lookup from a link association descriptor to find the corresponding PHY descriptor, a receiver always uses the combination of the modulation system type and the modulation system ID. This is, because the modulation system ID is only used to discriminate modulation systems of the same type, but not of different types. Hence the modulation system ID 0x010D in this example can be used by the DVB-S2 system and by one of the DVB-T2 systems, including for the same link, without creating inconsistencies.

Similarly, the PHY stream ID only discriminates PHY streams within a single modulation system. Hence the PHY stream ID 0x0007 in this example can be used by the DVB-S2 system and by one of the DVB-T2 systems, including for the same link, without creating inconsistencies.

A.4.2 Use of physical layer channel aggregation modes

A.4.2.1 DVB-C2 channel bundling

Figure A.6 shows an example for using DVB-C2 with channel bundling.

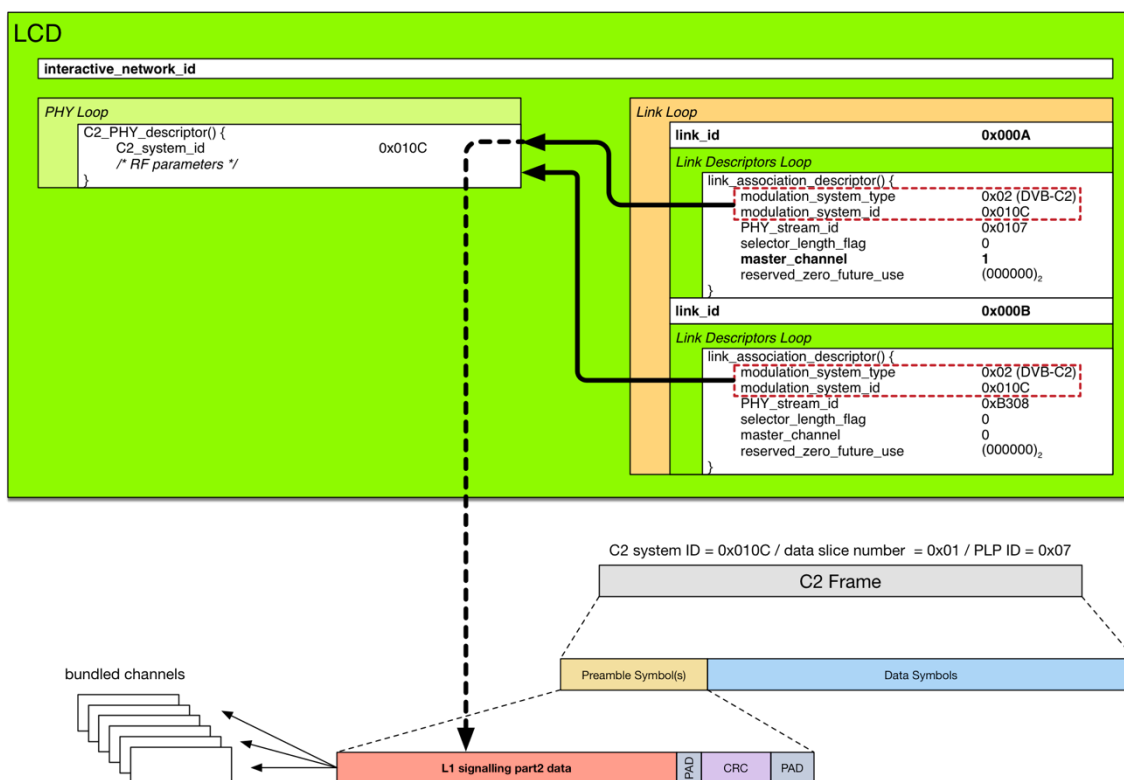

Figure A.6: Example of DVB-C2 channel bundling

The Link with link ID 0x000A in Figure A.6 is carried on the DVB-C2 system 0x010C, as is indicated by the modulation system type and modulation system ID in the respective link association descriptor. The data for this Link is carried in data slice 0x01 and in physical layer pipe (PLP) 0x07 (PHY_stream_id decomposed as defined in clause 8.4.5.15 of ETSI EN 301 192 [3]). The master channel flag in the selector field of the link association descriptor for this Link is set to one, indicating that this Link is carried using channel bundling, and that the PLP being referenced is to be used for synchronization (i.e. it is the master channel of the bundle). Which other, bundled data streams are needed to reconstruct the data stream is described in Layer 1 part 2 signalling (which is defined in clause 8 of ETSI EN 302 769 12) in the DVB-C2 signal itself; hence there is no need to list the bundled channels in the link association descriptor. These bundled channels may be carried in the same, or in different DVB-C2 modulation systems.

The second link in Figure A.6 with link ID 0x000B does not use channel bundling as the master channel flag in the selector field of the link association descriptor is set to zero. It is carried in the same DVB-C2 modulation system as Link 0x000A (C2 system ID 0x010C), but in the data slice 0xB3 in the PLP 0x08 (PHY_stream_id decomposed as defined in clause 8.4.5.15 of ETSI EN 301 192 [3]). The fact that Link 0x000B is carried in the same DVB-C2 modulation system as the Link 0x000A is purely coincidental, and has only been chosen for the sake of example to show that this is possible. Link 0x000B may of course just as well be carried in a different DVB-C2 modulation system.

A.4.2.2 DVB-S2X channel bonding and time slicing

Figure A.7 shows a simple example of using DVB-S2X channel bonding and time slicing. Since channel bonding and time slicing cannot be used at the same time, a DVB-S2X modulation system at any point in time may only use either one or the other, but not both. Since the format of data in the selector field of the link association descriptor depends on in which mode the DVB-S2X modulation system is being operated (see clause 5.2.2.11), the S2X_mode field in the corresponding PHY descriptor first needs to be consulted, before the format of data in the selector field can be known when processing a link association descriptor referencing a DVB-S2X modulation system.

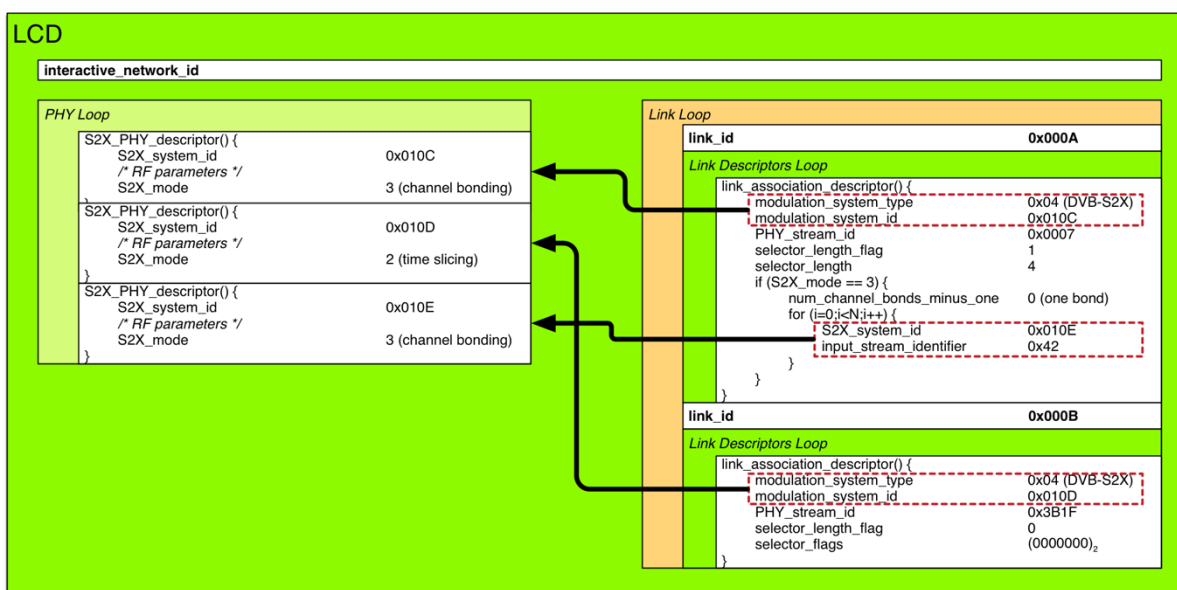

Figure A.7: Example of DVB-S2X channel bonding and time slicing

All DVB-S2X systems carrying the Link with ID 0x000A in Figure A.7 use channel bonding. The link association descriptor for Link 0x000A references the DVB-S2X modulation system with ID 0x010C. The PHY descriptor for this modulation system conveys an S2X_mode of three, which indicates that channel bonding is used. Since the reference to this DVB-S2X modulation system was made from the topmost level within the link association descriptor it can be inferred that the input stream with ID 0x07 (PHY_stream_id decomposed, and with the high order byte ignored since no time slicing is used) in the DVB-S2X modulation system 0x010C is the master channel of this bond, and since channel bonding is used it follows that the selector field of that link association descriptor contains information about the bonded non-master channels. In this example, the input stream 0x42 in the DVB-S2X modulation system 0x010E is bonded with the master channel.

The DVB-S2X system carrying the Link with ID 0x000B in Figure A.7 uses time slicing. The link association descriptor for Link 0x000B references the DVB-S2X modulation system with ID 0x010D. The PHY descriptor for this modulation system conveys an S2X_mode of two, which indicates that time slicing is used. The time slice number is encoded in the higher order byte, and the input stream identifier is encoded in the lower order of the PHY_stream_id (see clause 5.2.2.8). In this case, data for the Link 0x000B is hence carried in time slice number 0x3B in input stream 0x1F on the DVB-S2X system 0x010D. Since channel bonding is not used in this case (S2X_mode not equal to three), no information is conveyed in the selector field of this link association descriptor.

A.4.3 Example of Multicast transport

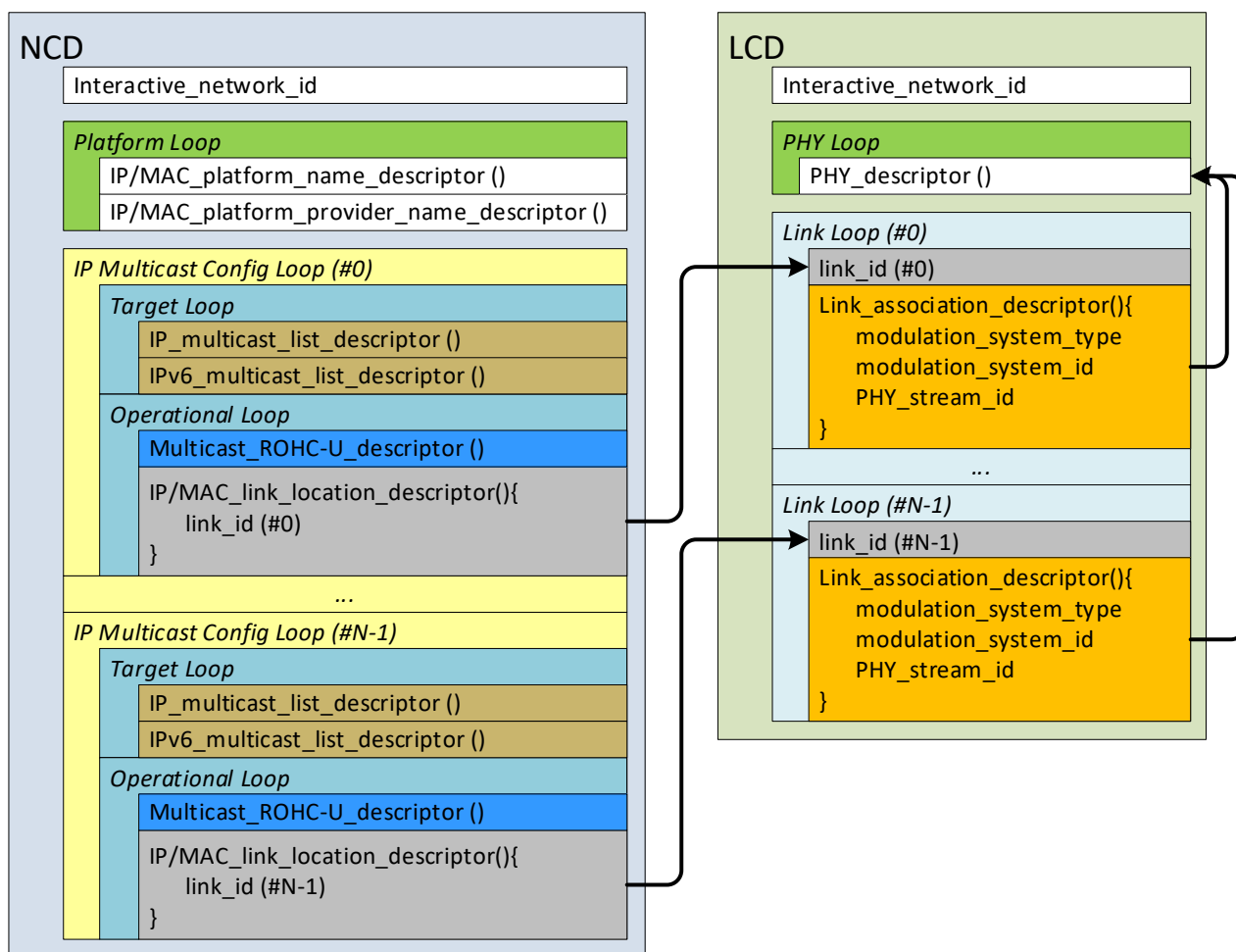

Figure A.8: Example of NCD and LCD for Multicast stream transport in DVB-GSE

Annex B (informative): Change History

Date	Version	Information about changes
October 2013	1.1.1	First publication of the TS after approval by TM #95 (23 - 24 October 2013; Geneva)
June 2016	1.2.1	Implemented Change Requests: <ul style="list-style-type: none"> • 1319: update C2 PHY descriptor for PLP bundling • 1391: missing curly brace in Table 2 • 1392: add a protocol version indication to the LLC index • 1464: update the S2 PHY descriptor text • 1465: add an S2X PHY descriptor • 1473: add selector field to the link association descriptor • 1488: add new headings for hanging paragraphs
February 2022	1.3.1 Interim draft (A116-2r2)	New descriptors to support IP/UDP based multicast streams with DVB-GSE. New descriptor to support multiple ROHC packet flow in a Link. Other editorial changes to incorporate above descriptors.
September 2024	1.3.1 Draft (A116-2r3)	New Descriptor to support beam hopping and non geostationary satellites

History

Document history		
V1.1.1	July 2014	Publication
V1.2.1	December 2016	Publication
V1.3.1 Interim draft	February 2022	BlueBook A116-2r2 publication
V1.3.1 Draft	September 2024	BlueBook A116-2r2 publication