



# **Native IP Broadcasting**

**DVB Document A180 Rev.1**

**July 2023**

**DVB<sup>®</sup>**

---

# Contents

Intellectual Property Rights .....	7
Foreword.....	7
Modal verbs terminology .....	7
Introduction .....	7
1 Scope .....	8
2 References .....	8
2.1 Normative references .....	8
2.2 Informative references .....	9
3 Definition of terms, symbols and abbreviations.....	9
3.1 Terms .....	9
3.2 Symbols .....	11
3.3 Abbreviations.....	11
4 System Description .....	13
4.1 Overview .....	13
4.2 System Features .....	14
5 Overall System Architecture .....	14
5.1 Introduction.....	14
5.2 Layered System Design .....	15
5.2.1 General .....	15
5.2.2 Core DVB Specifications underlying NIP (informative) .....	15
5.3 End-to-End System Architecture .....	16
5.4 NIP Headend Functions (informative).....	18
5.5 NIP Reference Points.....	19
6 Receiver Deployment Models (informative).....	19
6.1 Introduction.....	19
6.2 Generic Receiver Design .....	20
6.2.1 Introduction.....	20
6.2.2 NIP Gateway Functions .....	20
6.2.3 NIP Client Functions.....	21
6.3 Professional Edge Cache Receiver (DM1) .....	22
6.4 Integrated Native IP TV (DM2).....	23
6.5 Home Gateway + IP Client (DM3).....	24
6.6 Receiver Configurations and Deployment Models .....	25
7 Native IP Carriage.....	25
7.1 Introduction.....	25
7.2 Physical Layer: DVB-S2X, DVB-S2, DVB-T2.....	26
7.2.1 Overview .....	26
7.2.2 DVB-S2X.....	26
7.2.3 DVB-S2.....	27
7.2.4 DVB-T2 .....	27
7.3 Data link layer: GSE-Lite, MPE .....	28
7.3.1 Overview .....	28
7.3.2 Generic Stream Encapsulation (GSE), GSE-Lite profile .....	28
7.3.3 Multi-Protocol Encapsulation (MPE).....	28
7.3.4 NIP Stream Definition.....	29
7.4 Network Layer: IP Robust Header Compression (ROHC) .....	29
7.4.1 Introduction and Principles .....	29
7.4.2 ROHC channel mapping .....	30
7.4.3 Context ID (CID) assignment.....	30
7.4.4 Transmission of Context Information .....	30
7.4.5 Link Layer Signalling.....	31

7.4.6	Descriptors for the NIP system .....	31
7.4.7	Link Layer Signalling Example (informative) .....	32
7.5	Transport Layer: DVB-MABR .....	33
7.5.1	DVB-MABR Scope .....	33
7.5.2	Data Plane: DVB-MABR .....	34
8	Service Signalling Protocols .....	34
8.1	Signalling Overview .....	34
8.1.1	Introduction .....	34
8.1.2	Signalling Data Structures .....	34
8.1.3	Service Delivery Model .....	35
8.1.4	Bootstrap and Regular NIP Streams .....	35
8.1.4.1	Definition .....	35
8.1.4.2	NIP Stream Identifiers .....	35
8.1.5	Table Generation and Broadcast .....	36
8.1.6	Signalling Broadcast Location .....	36
8.1.7	Receiver Signalling Usage Sequence .....	37
8.1.7.1	Introduction .....	37
8.1.7.2	Receiver Bootstrapping Mechanism .....	37
8.1.7.3	Device Announcement and Discovery Mechanism .....	37
8.1.7.4	DVB-I Service List Discovery Mechanism .....	37
8.1.7.5	DVB-I Service Discovery Mechanism .....	38
8.1.7.6	Service Tuning and Service Access Mechanism .....	38
8.2	Signalling Carriage Description .....	38
8.2.1	Principles .....	38
8.2.2	IP Multicast Address, Port and TSI .....	38
8.2.3	Announcement Channel Structure .....	39
8.2.4	Announcement Channel FLUTE/ROUTE File Delivery Table .....	39
8.2.5	Announcement Channel Content .....	40
8.2.5.1	Payload Data .....	40
8.2.5.2	Payload Data Updates .....	41
8.2.5.3	Payload Data Compression .....	41
8.2.6	Announcement Channel Repetition Rates .....	41
8.3	Service Discovery and Programme Metadata: DVB-I .....	42
8.3.1	Overview .....	42
8.3.2	DVB-I Broadcast List Discovery: Service List Entry Points .....	42
8.3.2.1	Principles .....	42
8.3.2.2	DVB-I Broadcast Service List Discovery: Service List Registry Function .....	43
8.3.2.3	URL Coding in DVB-I Broadcast Service List Entry Points Table .....	43
8.3.3	DVB-I Broadcast Service Lists .....	43
8.3.3.1	Introduction .....	43
8.3.3.2	NIP Service Instances in DVB-I Service Lists .....	44
8.3.3.3	URL Coding for NIP Services declared in DVB-I Broadcast Lists .....	44
8.3.4	DVB-I Content Guide Metadata .....	45
8.3.4.1	Connected Receivers .....	45
8.3.4.2	Unconnected Receivers .....	45
8.4	Broadcast Network Signalling: NIF and SIF .....	45
8.4.1	Overview .....	45
8.4.2	Network Information File (NIF) Definition .....	46
8.4.2.1	NIF Purpose .....	46
8.4.2.2	Network Information File .....	46
8.4.2.2.1	NIF Schema Declaration .....	46
8.4.2.2.2	NetworkInformationFileType .....	46
8.4.2.2.3	BroadcastNetworkType .....	48
8.4.2.2.4	SatellitePositionType .....	49
8.4.2.2.5	NIPStreamType .....	49
8.4.2.2.6	DeliveryParametersTypes .....	51
8.4.2.2.6.1	DVBS2_NIPDeliveryParametersType .....	51
8.4.2.2.6.2	DVBS2X_NIPDeliveryParametersType .....	52
8.4.2.2.6.3	DVBT2_NIPDeliveryParameters .....	54
8.4.2.2.6.3.1	DVB_T2NIPDeliveryParametersType .....	54
8.4.2.2.6.3.2	long_T2_system_delivery_descriptorType .....	55

8.4.2.2.7	NIF Example.....	57
8.4.3	Service Information File (SIF) Definition.....	59
8.4.3.1	SIF Purpose.....	59
8.4.3.2	Service Information File.....	60
8.4.3.2.1	SIF Schema Declaration.....	60
8.4.3.2.2	ServiceInformationFileType.....	60
8.4.3.2.3	BroadcastMediaStreamType.....	60
8.4.3.2.4	Interactive Applications signalling structure.....	63
8.4.3.4.5	SIF Example.....	63
8.5	DVB-MABR Adaptation and Signalling.....	65
8.5.1	Introduction.....	65
8.5.2	Multicast Gateway Configuration.....	65
8.5.2.1	General.....	65
8.5.2.2	Bootstrapping: Bootstrap Multicast Gateway Configuration Instance Document.....	66
8.5.3	DVB-MABR Operation and Workflow.....	66
8.6	Time synchronisation.....	72
8.6.1	NIP Wall Clock.....	72
8.6.1.1	EXT_TIME Header Extension.....	72
8.6.1.2	Carriage of Timing Information.....	72
8.6.1.3	Global Time Reference.....	72
8.6.2	Local Time Offset.....	72
8.6.2.1	Time Offset File.....	72
8.6.2.2	TOF Schema Declaration.....	72
8.6.2.3	TimeOffsetFileType.....	72
8.6.2.4	TOF Example.....	73
8.6.3	Time Synchronisation between DVB-I Client and NIP Gateway.....	73
9	Application and Presentation Layer.....	74
9.1	Audio and Video Coding Standards.....	74
9.2	Captions and Subtitles.....	74
9.3	Time Shifting.....	74
9.4	Service Usage Reporting.....	74
10	Content Protection.....	74
10.1	Introduction.....	74
10.2	Connected Receivers.....	74
10.3	Unconnected Receivers.....	75
11	Deployment Specific Protocols.....	75
11.1	NIP Gateway Announcement and Discovery Protocol.....	75
11.1.1	Introduction.....	75
11.1.2	DNS-SD/mDNS.....	75
11.1.2.1	General.....	75
11.1.2.2	Pointer Record (PTR).....	75
11.1.2.3	Service Record (SRV).....	76
11.1.2.4	Text Record (TXT).....	76
11.2	Professional Edge Cache Receiver Configuration.....	77
11.2.1	Control API.....	77
<b>Annex A (normative): Transport Stream based carriage.....</b>		<b>78</b>
A.1	Introduction.....	78
A.2	Multi-Protocol Encapsulation (MPE).....	78
A.3	MPE Signalling.....	78
A.3.1	In the Network Information File.....	78
A.3.2	Linkage descriptor in a Transport Stream NIT or BAT.....	78
A.4	Simultaneous GSE-Lite and MPE operation.....	79
<b>Annex B (informative): Sequence Diagram.....</b>		<b>80</b>
<b>Annex C (informative): System Operation and Implementation Guidelines.....</b>		<b>81</b>

C.1	Introduction .....	81
C.2	Horizontal versus vertical market deployments .....	81
C.3	Recommendations to content originators .....	81
C.4	Recommendations to NIP Gateway manufacturers.....	81
C.4.1	Discovery of Bootstrap Streams .....	81
C.4.2	Switching between Provider Bootstrap Streams .....	82
C.4.3	Caching of Signalling Information .....	82
C.5	Support of MPEG/PES based services.....	82
C.5.1	DVB-I Service List signalling .....	82
C.5.2	Integrated Native IP TVs (DM2) .....	82
C.5.3	Home Gateway + IP Clients (DM3) .....	82
<b>Annex D (informative): Amendments to existing DVB specifications .....</b>		<b>83</b>
<b>Annex E (informative): Change History .....</b>		<b>84</b>

---

# Intellectual Property Rights

## Essential patents

IPRs essential or potentially essential to normative deliverables may have been declared to ETSI. The information pertaining to these essential IPRs, if any, is publicly available for **ETSI members and non-members**, and can be found in ETSI SR 000 314: *"Intellectual Property Rights (IPRs); Essential, or potentially Essential, IPRs notified to ETSI in respect of ETSI standards"*, which is available from the ETSI Secretariat. Latest updates are available on the ETSI Web server (<https://ipr.etsi.org>).

Pursuant to the ETSI IPR Policy, no investigation, including IPR searches, has been carried out by ETSI. No guarantee can be given as to the existence of other IPRs not referenced in ETSI SR 000 314 (or the updates on the ETSI Web server) which are, or may be, or may become, essential to the present document.

## Trademarks

The present document may include trademarks and/or tradenames which are asserted and/or registered by their owners. ETSI claims no ownership of these except for any which are indicated as being the property of ETSI, and conveys no right to use or reproduce any trademark and/or tradename. Mention of those trademarks in the present document does not constitute an endorsement by ETSI of products, services or organizations associated with those trademarks.

---

# Foreword

This Technical Specification (TS) has been produced by Joint Technical Committee (JTC) Broadcast of the European Broadcasting Union (EBU), Comité Européen de Normalisation ELECTrotechnique (CENELEC) and the European Telecommunications Standards Institute (ETSI).

**NOTE:** The EBU/ETSI JTC Broadcast was established in 1990 to co-ordinate the drafting of standards in the specific field of broadcasting and related fields. Since 1995 the JTC Broadcast became a tripartite body by including in the Memorandum of Understanding also CENELEC, which is responsible for the standardization of radio and television receivers. The EBU is a professional association of broadcasting organizations whose work includes the co-ordination of its members' activities in the technical, legal, programme-making and programme-exchange domains. The EBU has active members in about 60 countries in the European broadcasting area; its headquarters is in Geneva.

European Broadcasting Union  
CH-1218 GRAND SACONNEX (Geneva)  
Switzerland  
Tel: +41 22 717 21 11  
Fax: +41 22 717 24 81

---

# Modal verbs terminology

In the present document "**shall**", "**shall not**", "**should**", "**should not**", "**may**", "**need not**", "**will**", "**will not**", "**can**" and "**cannot**" are to be interpreted as described in clause 3.2 of the [ETSI Drafting Rules](#) (Verbal forms for the expression of provisions).

"**must**" and "**must not**" are **NOT** allowed in ETSI deliverables except when used in direct citation.

---

# Introduction

The present document specifies an end-to-end Native IP broadcast system for DVB broadcast bearers. It relies as much as possible on existing DVB specifications and complements those where necessary. The Native IP broadcast system is built upon DVB-I for service discovery and program metadata, DVB-AVC and DVB-DASH for source coding and stream formatting and DVB-MABR, DVB-GSE and the physical layer specifications DVB-S2X, DVB-S2 and DVB-T2 for transport. DVB Native IP facilitates the integration of OTT and Broadcast technologies into an efficient and contemporary IP media distribution solution.

The Native IP specification addresses both consumer and professional applications.

---

# 1 Scope

The present document describes a Native IP end-to-end broadcast system based on existing DVB standards.

---

## 2 References

### 2.1 Normative references

References are either specific (identified by date of publication and/or edition number or version number) or non-specific. For specific references, only the cited version applies. For non-specific references, the latest version of the referenced document (including any amendments) applies.

Referenced documents which are not found to be publicly available in the expected location might be found at <https://docbox.etsi.org/Reference>.

NOTE: While any hyperlinks included in this clause were valid at the time of publication, ETSI cannot guarantee their long term validity.

The following referenced documents are necessary for the application of the present document.

- [1] ETSI EN 302 307-1: "Digital Video Broadcasting (DVB); Second generation framing structure, channel coding and modulation systems for Broadcasting, Interactive Services, News Gathering and other broadband satellite applications; Part 1: DVB-S2".
- [2] ETSI EN 302 307-2: "Digital Video Broadcasting (DVB); Second generation framing structure, channel coding and modulation systems for Broadcasting, Interactive Services, News Gathering and other broadband satellite applications; Part 2: DVB-S2 Extensions (DVB-S2X)".
- [3] ETSI TS 102 755: "Digital Video Broadcasting (DVB); Frame structure channel coding and modulation for a second generation digital terrestrial television broadcasting system (DVB-T2)".
- [4] ETSI TS 102 606-1: "Digital Video Broadcasting (DVB); Generic Stream Encapsulation (GSE); Part 1: Protocol".
- [5] ETSI TS 102 606-2: "Digital Video Broadcasting (DVB); Generic Stream Encapsulation (GSE); Part 2: Logical Link Control (LLC)".
- [6] ETSI TS 102 606-3: "Digital Video Broadcasting (DVB); Generic Stream Encapsulation (GSE); Part 3: Robust Header Compression (RoHC) for IP".
- [7] ETSI EN 301 192: "Digital Video Broadcasting (DVB); DVB specification for data broadcasting".
- [8] ETSI TS 103 769: "Digital Video Broadcasting (DVB); Adaptive Media Streaming over IP multicast.
- [9] ETSI TS 103 770: "Digital Video Broadcasting (DVB); Service Discovery and Programme Metadata for DVB-I.
- [10] ETSI TS 101 154: "Digital Video Broadcasting (DVB); Specification for the use of Video and Audio Coding in Broadcast and Broadband Applications.
- [11] ETSI TS 103 285: "Digital Video Broadcasting (DVB); MPEG-DASH Profile for Transport of ISO BMFF Based DVB Services over IP Based Networks.
- [12] ETSI EN 303 560: "Digital Video Broadcasting (DVB); TTML Subtitling Systems.
- [13] DVB Document A179: "Digital Video Broadcasting (DVB); Service discovery and delivery protocols for a DVB Home Broadcast system.
- [14] ETSI EN 300 468: "Digital Video Broadcasting (DVB); Specification for Service Information (SI) in DVB systems".



- [15] ISO/IEC 13818-1: "Information technology -- Generic coding of moving pictures and associated audio information: Systems".
- [16] ETSI TS 102 034: "Digital Video Broadcasting (DVB); Transport of MPEG-2 TS Based DVB Services over IP Based Networks".
- [17] IETF RFC 6762: "Multicast DNS".
- [18] IETF RFC 6763: "DNS-Based Service Discovery".
- [19] IETF RFC 5328: "A UniformResourceName (URN) Namespace for the Digital Video Broadcasting Project (DVB)", A. Adolf and P. MacAvock
- [20] IETF RFC 1112: "Host Extensions for IP Multicasting"
- [21] IETF RFC 2464: "Transmission of IPv6 Packets over Ethernet Networks"
- [22] IETF RFC 1952: "GZIP file format specification version 4.3".
- [23] EN ISO 8601: "Data elements and interchange formats – Information interchange – Representation of dates and times"
- [24] IETF RFC 2782: "A DNS RR for specifying the location of services (DNS SRV) "
- [25] IETF RFC 1305: "Network Time Protocol (version 3)"
- [26] IETF RFC 5651: "Layered Coding Transport (LCT) Building Block"

## 2.2 Informative references

References are either specific (identified by date of publication and/or edition number or version number) or non-specific. For specific references, only the cited version applies. For non-specific references, the latest version of the referenced document (including any amendments) applies.

NOTE: While any hyperlinks included in this clause were valid at the time of publication, ETSI cannot guarantee their long term validity.

The following referenced documents are not necessary for the application of the present document but they assist the user with regard to a particular subject area.

- [i.1] ISO/IEC 23009-1:2019: "Information technology -- Dynamic adaptive streaming over HTTP (DASH) -- Part 1: Media presentation description and segment formats".
- [i.2] ISO/IEC 23001-7:2016: "Information technology -- MPEG systems technologies -- Part 7: Common encryption in ISO base media file format files".
- [i.3] W3C Recommendation: "XML Schema Definition Language (XSD) 1.1 Part 1: Structures".

NOTE: Available at <https://www.w3.org/TR/xmlschema11-1/>.

- [i.4] W3C Recommendation: "XML Schema Definition Language (XSD) 1.1 Part 2: Datatypes".

NOTE: Available at <https://www.w3.org/TR/xmlschema11-2/>.

---

## 3 Definition of terms, symbols and abbreviations

### 3.1 Terms

For the purposes of the present document, the following terms apply:

**aggregator:** any entity in charge of aggregating one or more bouquets of services

**asset:** any file object directly retrievable by NIP Clients through a URI

**bootstrap process:** initialization process for broadcast receivers joining a NIP broadcast network and learning about the topology of the network including the availability of channels, streams and services on those streams

**bootstrap streams:** any NIP stream according to the present document that is involved in the bootstrap or initialization process of receivers joining a NIP network and wanting to learn about the topology of the network

**broadcast service:** Any NIP Service broadcast over a NIP compliant network as opposed to a service provided via OTT

**broadcast service list:** A DVB-I Service List according to ETSI TS 103 770 [[9]] broadcast over a DVB-NIP Broadcast System and listing services available via broadcast or broadband

**broadcast service list entry points:** A Service List Entry Points file broadcast via a DVB-NIP Broadcast System according to the present document

NOTE: The Broadcast Service List Entry Points file provides to a DVB-I client the list of all DVB-I Service Lists that are broadcast on a NIP network.

**commercial operator:** any entity in charge of providing one or more bouquets of services. Commercial Operators typically aggregate services and provide these generally against payment but sometimes free-to-air to End-Users

**connected device:** any device, capable of receiving broadcast content and also connected to a terrestrial fixed or mobile broadband network or connected to a satellite network with return channel functionality providing access to the open internet

**content preparation platform:** all functions involved in the video encoding, encryption, key management and packaging of media assets for broadcast via a NIP compliant network

**deployment model:** refers to a logical grouping of receiver functions or features for a particular usage scenario

**DVB-I Client:** implementation of the client side of ETSI TS 103 770 [9]

NOTE: This may be integrated into the User Interface (UI) of a device such as a television or set-top box or part of an app on devices such as mobile phones or tablets.

**DVB-NIP Broadcast System:** an end-to-end broadcast system that complies with the specification of the present document

**DVB-TS Broadcast Headend:** in the context of the present document refers to the functions part of a traditional Transport Stream based DVB Head-end: Linear encoding into PES packets, DVB Multiplexing, DVB Conditional Access etc

**headend:** all functions involved in the editing of services before being broadcast

**hybrid service:** service consisting of components carried via a.) broadcast and b.) broadband means

**media object:** single externally addressable unit of packaged encoded media essence or related metadata to be conveyed via a multicast transport session or via a unicast transport session e.g. a presentation manifest or DASH segment identified by a URI

**metadata:** all data related to the description of the network: Channels and Streams, Services available on the Network: Service List Entry Points and Service Lists, Content within those services: Content Guide and Content Presentation

**multicast gateway:** as defined in clause 5.3.5 of ETSI TS 103 769 [8]

**multicast rendezvous service:** as defined in clause 5.3.9 of ETSI TS 103 769 [8]

**multicast server:** as defined in clause 5.3.3 of ETSI TS 103 769 [8]

**NIP Client:** device or software application featuring DVB-I client functionality as defined in ETSI TS 103 770 [9], including the capability to decode, decrypt and display NIP Services plus depending on the deployment scenario, the NIP defined device discovery methods in clause 11.1 of the present document

**NIP Gateway:** device including one or more broadcast reception frontends plus all functions required to interface with DVB-NIP Clients according to the present document

**NIP Receiver:** generic term for a reception device according to the present document

NOTE: The NIP Receiver always includes at least one or more physical broadcast tuner/demodulator functions, capable of receiving streams according to the present document. The NIP receiver may additionally include some or all NIP Gateway functions as well as some or all NIP Client functions.

**NIP Service:** any service according to DVB-I (ETSI TS 103 770) [[9]] which is discovered using the mechanisms defined in the present document, and which is using DVB-DASH (ETSI TS 103 285 [11]) delivery via broadcast or broadband

**NIP Service Aggregation Platform:** all head-end components, cloud or on-premises, at the Technical Network Operator or at one or more Commercial Operator(s) involved in the compilation of signalling and metadata information for the correct operation of NIP broadcast services according to the present document

**NIP Service Identifier:** URL of the NIP Service manifest

**NIP Stream:** Layer 2 packet stream consisting of a succession of GSE-Lite packets or TS/MPE sections

**NIP Wall Clock:** UTC time synchronized between head-end and NIP receivers

**over-the-top (OTT):** a media service offered directly to viewers via the Internet. OTT bypasses cable, broadcast, and satellite television platforms

**provider name:** the name of the provider of a DVB-I (ETSI TS 103 770 [9]) Service List in a human readable form

**regular stream:** any NIP Stream according to the present document that carries NIP Services but does not carry information specifically required during the bootstrap process of receivers

**regulator:** entity in charge of defining rules for broadcasters and the editing of broadcast programs

NOTE: In the context of the present document, the regulator is considered a key source when defining regionally applicable Service Lists.

**reserved\_zero\_future\_use:** when used in the clause defining the coded bit stream, indicates that the value may be used in the future for ETSI defined extensions

NOTE: All "reserved\_zero\_future\_use" bits are set to "0".

**RF Carrier:** modulated radio frequency signal carrying one or more NIP Streams

**RF Channel:** refers to a logical subdivision of the RF broadcast spectrum

NOTE: In the context of satellite transmissions RF Channels are commonly called Transponders.

**technical network operator:** entity in charge of running the broadcast network

## 3.2 Symbols

Void.

## 3.3 Abbreviations

For the purposes of the present document, the following abbreviations apply:

ABR	Adaptive Bit Rate
API	Application Programming Interface
ASCII	American Standard Code for Information Interchange
AV	Audio Visual
AVC	Advanced Video Coding
B2B	Business to Business
B2C	Business to Consumer
CA	Conditional Access
CDN	Content Delivery Network
CENC	Common Encryption
CSR	Central Service Registry

DASH	Dynamic Adaptive Streaming over HTTP
DASH-IF	DASH Industry Forum
DM	Deployment Model
DRM	Digital Rights Management
DTT	Digital Terrestrial Television
DVB-HB	Digital Video Broadcasting – Home Broadcast
DVB-I	Digital Video Broadcasting – Internet
DVB-SI	Digital Video Broadcasting – Service Information
EME	Encrypted Media Extensions
EPG	Electronic Programme Guide
ETSI	European Telecommunications Standards Institute
FLUTE	File Delivery over Unidirectional Transport
GSE	Generic Stream Encapsulation
HbbTV	Hybrid Broadcast Broadband Television
HEVC	High Efficiency Video Coding
HEM	High Efficiency Mode
HD	High Definition
HDMI	High-Definition Multimedia Interface
HLS	HTTP Live Streaming
HTML	HyperText Markup Language
HTTP	HyperText Transfer Protocol
HTTPS	HyperText Transfer Protocol Secure
IANA	Internet Assigned Numbers Authority
ID	Identifier
IEC	International Electrotechnical Commission
IETF	Internet Engineering Task Force
IP	Internet Protocol
IPTV	Internet Protocol Television
ISI	Input Stream Identifier
ISO	International Standards Organization
ISP	Internet Service Provider
LAN	Local Area Network
LCD	Link Control Data
LCN	Logical Channel Numbering
LNB	Low Noise Block
MABR	Multicast Adaptive Bit Rate
MAC	Media Access Control
MPD	Media Presentation Description
MPE	Multiprotocol Encapsulation
MPEG	Moving Picture Experts Group
NIC	Network Interface Card
NID	Network Identifier
NIF	Network Information File
NIP	DVB Native IP
NIT	Network Information Table
NCD	Network Control Data
NTP	Network Time Protocol
OTT	Over The Top
PES	MPEG Packetized Elementary Stream
PHY	Physical Layer
PLP	Physical Layer Pipe
PTP	Precision Time Protocol
RF	Radio Frequency
RFC	Request For Comments
RoHC	Robust Header Compression
ROUTE	Real-Time Object Delivery over Unidirectional Transport
RTP	Real-Time Transfer Protocol
RX	Receiver
SD	Standard Definition
SDT	Service Description Table
SIF	Service Information File
SLR	DVB-I Service List Registry

STB	Set-Top Box
TCP	Transmission Control Protocol
TLS	Transport Layer Security
TRP	Transponder
TS	MPEG Transport Stream
TX	Transmitter
UDP	User Datagram Protocol
UHD	Ultra High Definition
UI	User Interface
URI	Uniform Resource Identifier
URL	Universal Resource Locator
URN	Universal Resource Name
USB	Universal Serial Bus
UTC	Coordinated Universal Time
UTF-8	Unicode Transformation Format, 8 bit
VoD	Video on Demand
XML	Extensible Markup Language

---

## 4 System Description

### 4.1 Overview

The present document describes a Native IP (NIP) Broadcast System based on existing DVB technologies that have been adapted and complemented for the requirements of network operators and broadcasters that want to leverage IP for the distribution of content.

It is designed to be applicable to DVB-S2X, DVB-S2 and DVB-T2 based broadcast networks.

The Native IP Broadcast System is an end-to-end IP-based system architecture that leverages DVB-I as a contemporary service discovery and programme metadata scheme, state-of-the-art Adaptive Bit Rate (ABR) video coding, packaging and delivery technologies as specified in DVB-DASH [11] and DVB-AVC [10] and multicast file transfer mechanisms as specified in DVB-MABR [8] for the distribution of audio-visual content.

The advantages of this approach are more flexibility, better integration with terrestrial IP infrastructures, the possibility to re-use streams coming from OTT cloud head-ends rather than having to purposely run a DVB-TS Broadcast Head-end for the sole distribution via traditional DVB broadcast networks, better compatibility with contemporary IP devices, such as smartphones, tablets, PCs..., and finally the option to use one and the same Native IP broadcast transmission to simultaneously address several very different B2B and B2C use cases.

Leveraging ABR technologies makes it possible to provide AV assets reliably not only directly to TV sets but also indirectly via gateway functions to any contemporary IP device. Such gateways may sit in provider and telecom networks or directly in consumer's homes as an extension to DVB Home Broadcast [13].

Using the mechanisms defined in DVB-MABR also makes it possible to provide fully and inherently hybrid services in a totally seamless manner with some service components being delivered via broadcast and others via OTT. All this being invisible to the end-user. Applications for this may be live television channels carrying Targeted Advertising wherein the live channel content is provided via broadcast and the Targeted Advertisements are being delivered invisibly via broadband, or services where the lesser watched representations are delivered via broadband and the most common representations/components are delivered via broadcast. All the content seamlessly blends in a single consistent presentation to the end-user.

The mass distribution of identical content is still best served via broadcast and by leveraging contemporary video technologies in a hybrid context, the best of IP unicast and IP multicast distribution can be seamlessly combined.

Finally, the continued use of broadcast technologies in large scale content distribution systems represents a non-negligible contribution by the television industry to making television sustainable and contributing to the preservation of scarce resources.

## 4.2 System Features

The DVB Native IP Broadcast System works in both connected and unconnected scenarios. In unconnected scenarios, i.e. without return path, some features are not available yet.

The core features of the Native IP solution are:

1. Carriage of real-time live linear television and radio services
  - Real-time delivery of assets purely via broadcast.
  - Real-time delivery of assets in a fully hybrid manner some via broadcast and some via broadband.
  - Easier upgrade for the introduction of new audio and video codecs.
2. Professional and Consumer Usage Scenarios
  - Delivered directly from the same head-end to - consumers homes or indirectly – to CDN Edge Caches which make the content available via intermediate LAN or WAN fixed or mobile networks.
  - In professional environments, the possibility to store received content, i.e. "Live to VoD" service.
3. Extended Content Guide
  - All the functionalities provided by DVB-I ETSI TS 103 770 [9].
4. Multiscreen support
  - Addresses Native IP devices with or without built-in broadcast tuner.
5. Content protection
  - Supports content protection with the same DRM solutions that are used on broadband networks (fully connected scenario).
  - Supports proprietary DRM solutions for unconnected client scenarios.
6. Targeted Advertising
  - Uses the advantages of ABR for flexible ad replacement.
7. Accessibility services
  - Supports EBU-defined subtitling.

---

## 5 Overall System Architecture

### 5.1 Introduction

The DVB Native IP (DVB-NIP) specification describes an end-to-end IP delivery architecture leveraging Internet content delivery technologies such as Adaptive Bit Rate (ABR) streaming also for broadcast applications. The DVB-NIP Broadcast System is made up of two major parts (see figure 5.3-1):

- All functions related to the Native IP Headend.
- All functions related to the Native IP broadcast reception and content consumption.

The overall system design and the headend functions are described in the present clause. The receiver functions are described in clause 6.

## 5.2 Layered System Design

### 5.2.1 General

The DVB-NIP Broadcast System relies on a layered system architecture.

At the top of the Native IP stack is a DVB-I based television service discovery and metadata layer according to ETSI TS 103 770 [9]. This layer is responsible for informing receivers about the various services available on the broadcast and broadband networks. DVB-NIP Services may be grouped into different DVB-I Service Lists coming from different Technical or Commercial Operators on the broadcast network. One or more such DVB-I Service List(s) may be present on each broadcast network. The DVB-I Service List Entry Points mechanism is used to announce all the different DVB-I Broadcast Lists available on the network.

Included in each DVB-I service list are DVB-DASH based services according to ETSI TS 103 285 [11]. DVB-DASH based services in DVB-NIP can be carried using the DVB-MABR defined FLUTE/ROUTE protocols via the DVB broadcast network as defined in ETSI TS 103 769 [8]. Alternatively, a receiver might fetch the same services using standard HTTP/HTTPS requests via the broadband network. In addition, some components or representations of the same DASH service may be carried via the broadcast network and others via the broadband network. All this shall happen invisibly to the end-user of such services.

DVB-NIP defines an Announcement Channel mechanism under clause 8.2 and signalling tables called the NIF (Network Information File) and the SIF (Service Information File) under clause 8.4. These two signalling tables enable all the previously mentioned DVB specifications to be run on a broadcast network consisting of several broadcast RF Channels and potentially one or more logical NIP Streams. The NIF provides information about the different Streams and their physical parameters on the broadcast network. The SIF provides information on the location of Services and metadata within those Streams. NIF plus SIF allow broadcast receivers to dynamically re-tune to the Streams and physical Channels carrying the different broadcast Services.

Signalling and A/V Services (using DVB-DASH ETSI TS 103 285 [11]) are carried on the broadcast RF Channel via IP multicast. DVB-NIP IP multicast sessions are carried using the GSE-Lite Profile as defined in clause D.2 of ETSI TS 102 606-1 [4] or Multiple Protocol Encapsulation as defined in ETSI EN 301 192 [7] at the Data Link Layer and DVB-S2X (ETSI 302 307-1 [1], ETSI 302 307-2 [2]), DVB-S2 (ETSI 302 307-1 [1]) and DVB-T2 (ETSI TS 102 755 [3]) at the Physical Layer. See figure 5.2.1-1, below.

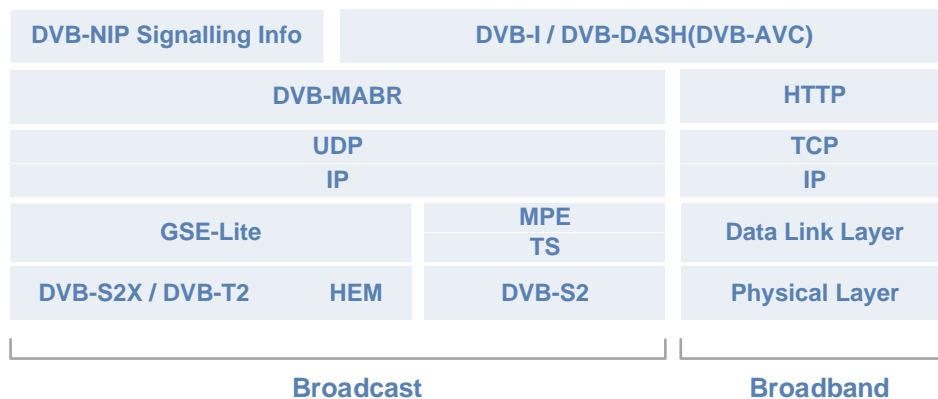

Figure 5.2.1-1: DVB-NIP protocol stack

### 5.2.2 Core DVB Specifications underlying NIP (informative)

The DVB-NIP Broadcast System is based on the following core DVB specifications. This list is purely informative and the exhaustive list is provided in clause 2.

- DVB-I (ETSI TS 103 770 [9]) provides the service discovery and programme metadata scheme for the DVB-NIP Broadcast System. DVB-NIP is designed in such a manner as to allow the re-use of unmodified DVB-I Clients. All features present in DVB-I are also available to DVB-NIP Clients. In particular DVB-I is used in DVB-NIP for announcing the media services that are available via broadcast and/or broadband.

- DVB-DASH (ETSI TS 103 285 [11]) and DVB-AVC (ETSI TS 101 154 [10]) are the underlying specifications for the coding, packaging and distribution of audio-visual services in the context of DVB-NIP.
- DVB-MABR (ETSI TS 103 769 [8]): DVB-NIP leverages the multicast object transport solution(s) provided by DVB-MABR for the carriage of file-based content, including segmented media.
- DVB-GSE (ETSI TS 102 660-1 [4]) and DVB-MPE (ETSI EN 301 192 [7]) are the two link layer protocols selected for the carriage of IP multicast datagrams in DVB-NIP. DVB-GSE is applied to the latest DVB physical layer specifications whereas MPE is used as an S2 compatible solution.
- DVB-S2X (ETSI 302 307-1 [1], ETSI 302 307-2 [2]), DVB-S2 (ETSI 302 307-1 [1]) and DVB-T2 (ETSI TS 102 755 [3]) may be used as the physical layer specifications in the context of an end-to-end DVB-NIP Broadcast System.

## 5.3 End-to-End System Architecture

The DVB-NIP Broadcast System is significantly different from traditional Transport Stream based broadcast architectures. Content sourcing in a NIP context is no longer from a dedicated DVB Encoding Platform but from the same Content Preparation and Hosting Platform that also source(s) OTT platforms. The OTT headend functions can run in the public cloud or on the premises of a Technical Network Operator or Commercial Operator. The interface between the OTT Content Preparation and Hosting Platform and the NIP platform is as described in clause 5.3.3.1 of the DVB-MABR specification [8].

The NIP architecture consists at the top level of NIP Headend and NIP Receiver functions. These NIP Headend and NIP Receiver functions can be subdivided into smaller functions that may themselves be grouped again into logical entities. NIP Headend functions will be described hereunder in clause 5 and the NIP Receiver logical functions are described in clause 6.

Figure 5.3-1 shows the overall NIP architecture. Logical functions are represented as named boxes and these boxes may be nested in cases where a higher-level function is composed of several subfunctions.



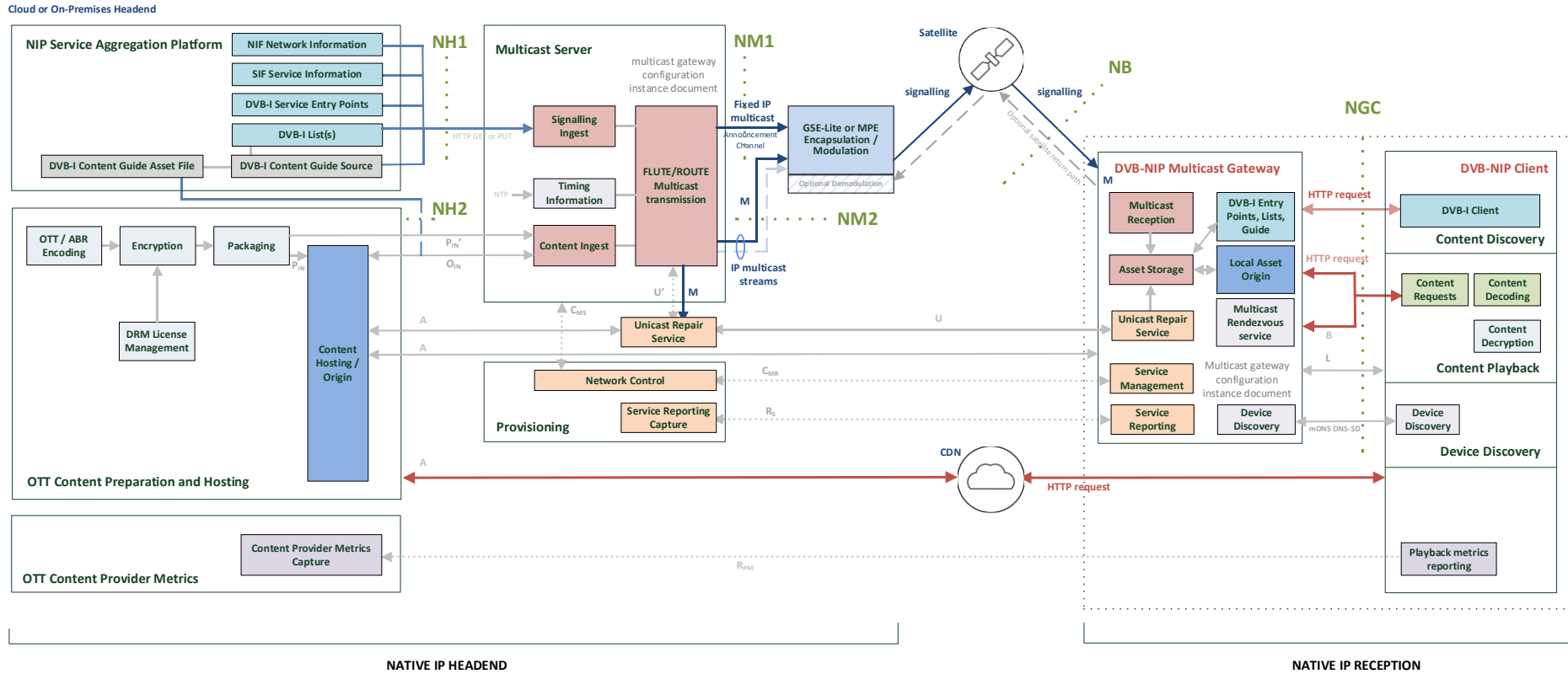

Figure 5.3-1: Architecture of the DVB-NIP Broadcast System

Figure 5.3-1 shows the overall NIP architecture. Logical functions are represented as named boxes and these boxes may be nested in cases where a higher-level function is composed of several lower-level functions.

## 5.4 NIP Headend Functions (informative)

The DVB-NIP Headend is made up of the following high-level functions (each with nested sub-functions):

1. The *OTT Content Preparation and Hosting platform* consists of media encoding, Content Encryption, Content Packaging and Content Hosting functions. It generally provides the same streams for over-the-top content delivery and, in the case of a DVB-NIP system, also for delivery via Native IP broadcasting. The OTT Content Preparation and Hosting platform can run at the premises of the broadcaster or can be run entirely in the cloud. It may be a single fully integrated and co-located headend, or it may comprise a collection of distributed headends, with each headend responsible for a few NIP Services. The OTT Content Preparation and Hosting platform interfaces with the Multicast server function at reference points **O<sub>in</sub>**, **P<sub>in</sub>** or **P<sub>in</sub>'** as defined in clause 5.3.3.1 of ETSI TS 103 769 [8].
2. The *NIP Service Aggregation Platform* is responsible for:
  - The compilation of one or more DVB-I Service List(s).
  - The compilation of a list of DVB-I Service List Entry Points that is conveyed to NIP Gateways via the signalling channel and which helps DVB-I Clients select the corresponding DVB-I Service List that is to be used for receiving NIP services.
  - The creation of the NIF table which associates logical identification of streams and their physical parameters on the broadcast network.
  - The creation of the SIF table which associates services and metadata with their logical location on the broadcast network.
  - The compilation of the broadcast specific DVB-I Content Guide.

The NIP Service Aggregation platform may be operator-specific or can be a shared system running in a private or public cloud.

3. The *Content Provider platform* deals with content acquisition, scheduling and monetisation. It is also in charge of collecting usage analytics from subscribers. It is not further described in the present document.
4. The *NIP Signalling Server* builds the multicast signalling channel specified in clause 8.2. The NIP Signalling Server gets the information from the NIP Service Aggregation platform and generates one or more multicast signalling channels. Each channel, on a fixed multicast IP address, is associated with a particular NIP Stream. The NIP Signalling Server may be a standalone unit or may be part of the modulator(s) generating the DVB-NIP-compliant broadcast stream(s). The NIP Signalling Server provides signalling information regarding the physical and logical parameters of NIP services as well as accurate system time information.
5. The *Multicast server* is specified in ETSI TS 103 769 [8] and is responsible for generating multicast transport sessions carrying one or more DVB-DASH Services. One Multicast server instance is associated with one logical NIP Stream. The Multicast server is responsible for managing, at any time, the bit rate allocation(s) across the generated multicast transport sessions.
6. The *Service Provisioning Platform* represents all operational support systems, handling the platform headend operation and service reporting from *Multicast Gateway* devices.
7. The *Encapsulation and Modulation* function handles the encapsulation of IP multicast datagrams into NIP Streams according to clause 7.3.4 and RF signal modulation according to the Physical Layer Specifications described in clause 7.2. If available, robust header compression as defined in clause 7.4 may be applied to incoming multicast signals.

## 5.5 NIP Reference Points

The following is a listing of logical reference points specific to the DVB-NIP Broadcast System as specified in the present document (see figure 5.3-1):

- NH1:** The interface between the Native IP Service Aggregation platform and the Native IP Signalling Server.
- NH2:** The interface between the Broadcast DVB-I Content Guide Asset File and the Multicast Server.
- NM1:** The interface between the NIP Signalling Server and the GSE/MPE Encapsulator/Modulator. This interface carries the IP multicast Announcement Channel.
- NM2:** The interface between the *Multicast Server* and the GSE/MPE Encapsulator/Modulator. This interface shall be compliant with reference point **M** interface as defined by DVB-MABR in ETSI TS 103 769 [8].
- NB:** Over-the-air interface carrying Native IP Broadcast physical and data link layer signals as specified in clause 7 of the present document. This interface carries the following network layer signals:
- The IP multicast transport sessions originating from the *Multicast Server* as defined in ETSI TS 103 769 [8] and according to clause 8.5 of the present document.
  - The IP multicast Announcement Channel according to clause 8.2 of the present document.
- NGC:** The NIP Gateway to Client Interface specifies the interactions between the NIP Client functions and the NIP Gateway functions. This interface is specified in clauses 8.3, 8.5 and 11.1.

## 6 Receiver Deployment Models (informative)

### 6.1 Introduction

The present specification targets three receiver Deployment Models (DMs) in particular. This listing is not exhaustive, and industry can come up with other Deployments Models, but this particular logical grouping should help implementations of Native IP receivers. Other deployment models not described here may be added in subsequent releases of the present specification.

The intention is that the same DVB Native IP media distribution system can feed all three of the Deployment Models presented here with the same identical broadcast streams.

The first Deployment Model (DM1) represents a professional business-to-business (B2B) scenario with professional edge cache receivers installed at the edge of provider or telecom networks. These edge cache receivers are fed via the DVB broadcast network. Such edges may be telecom nodes for fixed and mobile networks, local CDN caches, broadcast transmitter nodes, caches on board of cruise ships and planes, hotspots in underserved areas etc. These nodes will feed DVB-I clients indirectly via respective intermediary public or private IP networks. Professional edge caches may rely only on a subset of the functions specified in the present document but shall leverage the same transport and stream formats specified herein.

The second (DM2) and third (DM3) deployment models are business-to-consumer (B2C) oriented models.

The second deployment model DM2 is directly addressing next generation TV sets implementing Native IP broadcast reception capabilities as a part of their built-in broadcast stack. Such television sets provide access to Native IP delivered services as they do with DVB Transport Stream based systems, but leverage DVB-I functionality together with latest generation DASH delivery and contemporary video and audio coding technologies. These Native IP television sets enable a full hybridisation of television services with some service components being delivered via broadcast and some via broadband connectivity. Wherever the service components are sourced, this happens entirely invisibly to the end-user who only sees a consistent service presentation.

The third deployment scenario DM3 is for services provided directly to all-IP end-consumer devices at home. Such services will rely on a Native IP Gateway function being available at home. Such Native IP Gateway function may reside in an existing device (e.g. a television set according to DM2 feeding also other mobile devices at home) or may

be a separate device such as a STB, antenna adapter, signal distribution component, ISP router, or a dedicated low-cost server device with broadcast reception functionality.

## 6.2 Generic Receiver Design

### 6.2.1 Introduction

This clause describes the generic virtual functions that are part of NIP Receivers. Not all receivers need to implement all functions. Receiver functions are there to describe and structure the receiver design. Some functions may be combined, or some functions may not exist at all in some receiver implementations. Clause 6.6 describes which receiver functions are mandatory, optional or not applicable in each of the deployment models (DMs) described in this document.

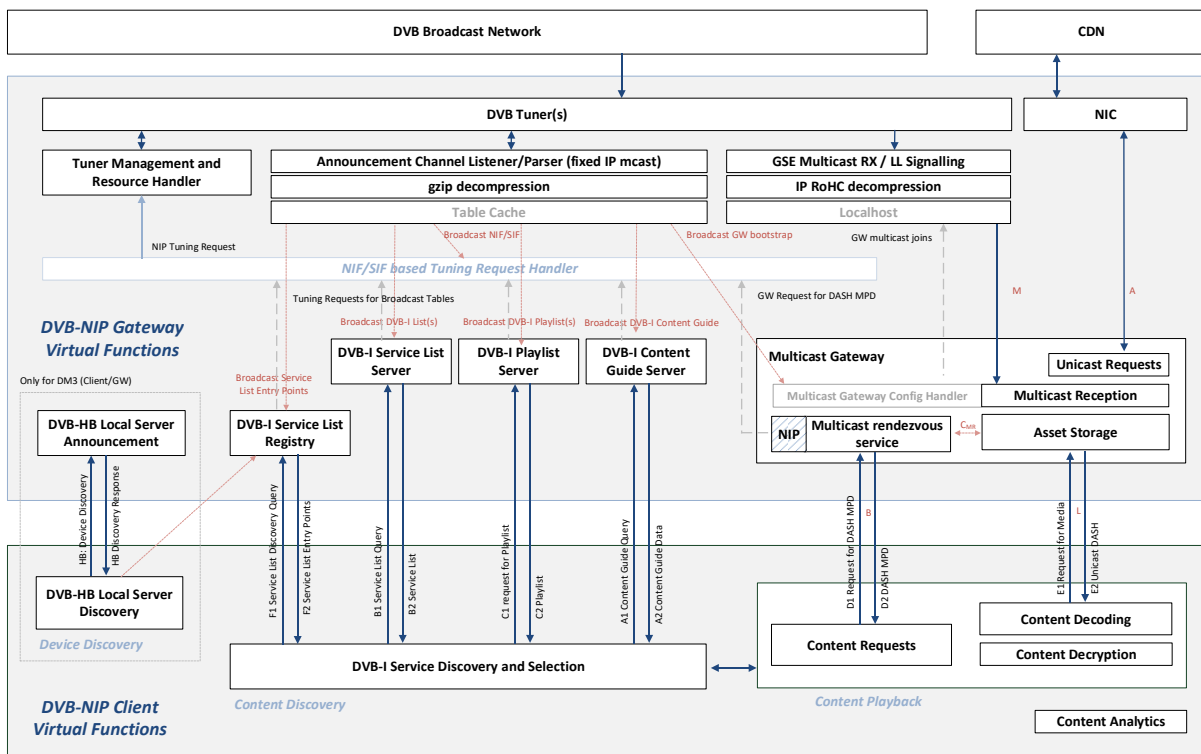

**Figure 6.2.1-1: DVB-NIP Generic Receiver Architecture (informative)**

Functionally NIP Receivers can be split into two parts: A high level NIP Gateway function and a high-level NIP Client function. The gateway function typically contains one or more DVB tuners that physically receive the NIP broadcast transmissions and forwards them onto a logical or physical IP network connection. The NIP Client function is typically an off-the-shelves DVB-I Client and provides access to the actual content transmitted. All interactions between NIP Client and NIP Gateway functions shall be according to ETSI EN 103 770 [9].

### 6.2.2 NIP Gateway Functions

All NIP Gateways shall include the following sub-functions:

- Single or multiple DVB-S2/S2X/T2 tuner(s)/demodulator(s).
- The capability to receive at least one of the two: MPE via TS or GSE-Lite via GSE-HEM.
- The capability to receive IP multicast streams (with and without IP Robust Header Compression applied).
- The capability to receive and parse the NIP announcement channel.
- The capability to temporarily store assets received from the broadcast network.
- The capability to serve assets to clients using HTTP.

- The capability to connect to a broadband network to retrieve content assets or metadata.

Some NIP Gateways may additionally include the following sub-functions:

- The capability to announce themselves on the local network to which they may be connected.
- The capability to answer DVB-I Service List Entry Points Queries.
- The capability to be remotely configured.

### 6.2.3 NIP Client Functions

The NIP Client includes the following sub-functions:

- The capability to interact with a DVB-I Service List Entry Points Registry Server.
- The capability to interact with a DVB-I Service List Server.
- The capability to display a DVB-I Service List to the End User.
- The capability to select the most appropriate instance from a DVB-I List.
- The capability to discover a NIP Gateway.
- The capability to request and display NIP services.

## 6.3 Professional Edge Cache Receiver (DM1)

Professional Edge Cache Receivers according to the present document are deployed at the edge of telecom, CDN or broadcast networks or act as local wireless hotspots. They receive DVB-NIP formatted content from a broadcast network via multicast and make that content available locally to other networks (e.g. CDN, Fixed, Mobile, Wi-Fi Hotspot or DVB networks), which in-turn indirectly feed IP clients wanting to access that content.

Professional Edge Cache Broadcast Receivers are installed when a massive distribution of identical content is required and where the large multiplication effect of broadcast technologies can bring considerable distribution gains.

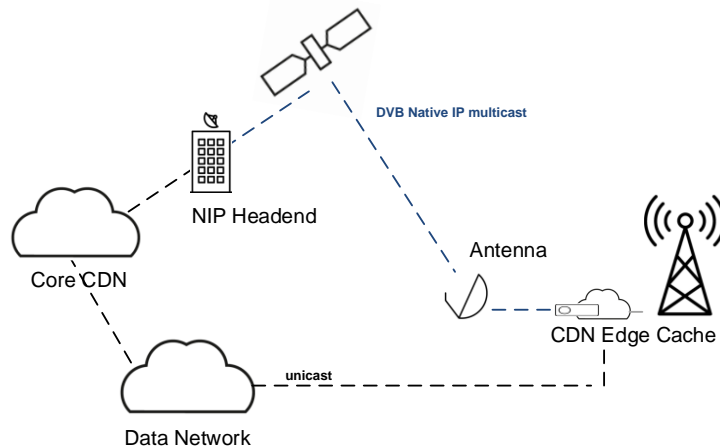

**Figure 6.3-1: Example of a Professional Edge Cache receiver at the edge of a CDN network**

Professional Edge Cache receivers generally feature multi-tuner front-ends for the parallel reception of multiple DVB-NIP Streams and extensive storage space to act as large local data caches. Professional Edge Caches generally act as local http/https web servers with reverse proxy functionality. The exact interaction between such proxies and clients, and the way that clients get re-directed to these caches is outside the scope of the present document. Clause 6.6 lists the functions that are mandatory, optional or not applicable for professional receiver implementations.

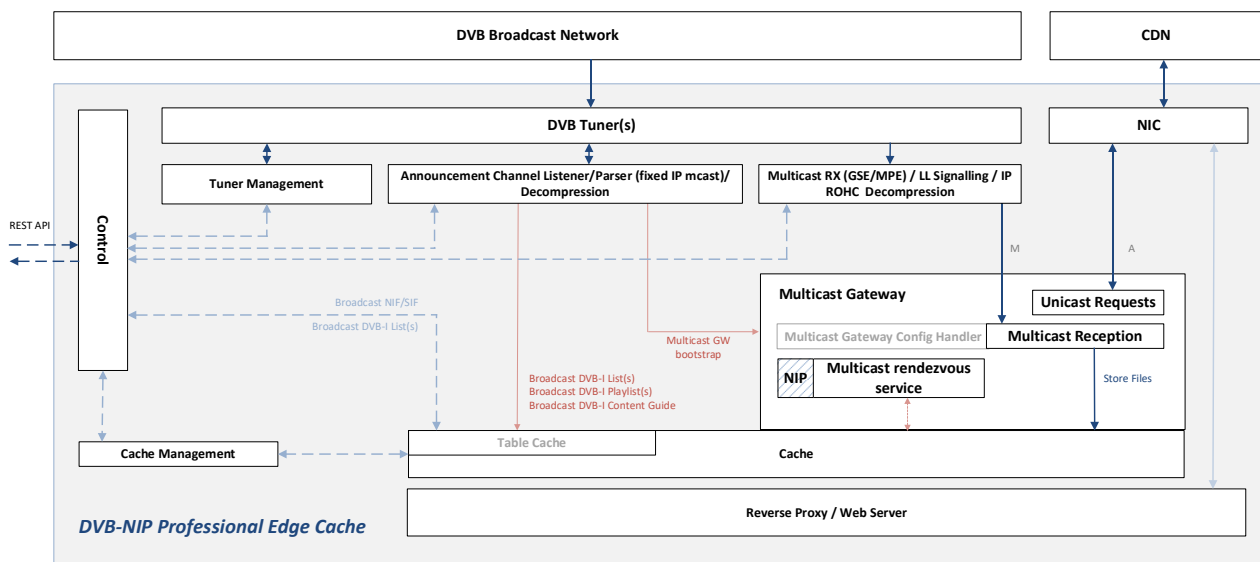

**Figure 6.3-2: DVB-NIP DM1 Receiver Architecture (informative)**

## 6.4 Integrated Native IP TV (DM2)

The same DVB-NIP broadcast streams that are built for feeding professional DM1 receivers can also be used for direct reception at home. The simplest reception solution for consumer applications under the present document is DM2. It refers to a fully integrated smart television set. Television sets according to DM2 might be capable of receiving, in addition to legacy Transport Stream (TS) based television services also, television transmissions that are carried natively in IP over the broadcast network. DM2 receivers may or may not be connected to a broadband network.

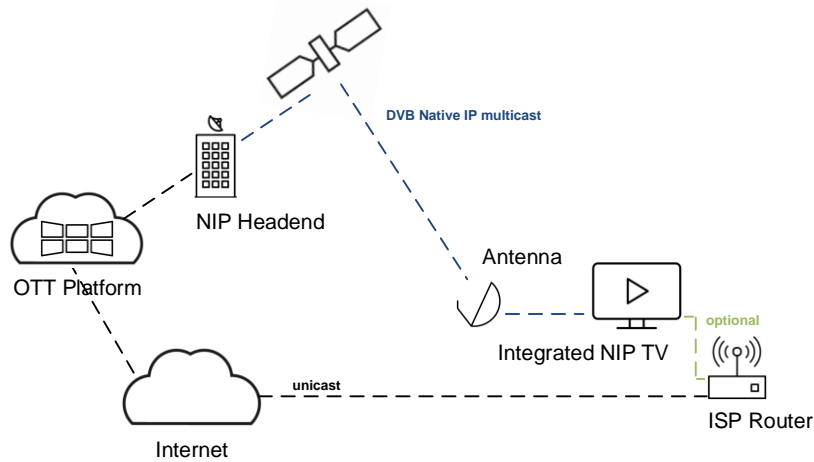

**Figure 6.4-1: Simplified view of Deployment Model 2**

DM2 television sets are capable of receiving via broadcast the same streams that are potentially made available also via OTT platforms and CDN distribution networks. They implement DVB-I and DVB-DASH defined mechanisms. These television sets are also able to seamlessly blend, in a fully hybrid manner, streams that are received via broadcast with streams that are delivered via OTT. As an example, a given DVB-I service may have some DVB-DASH representations and/or components that are available via broadcast and others that are only available terrestrially. Native IP television sets can indistinguishably present such services to end users as one and the same service.

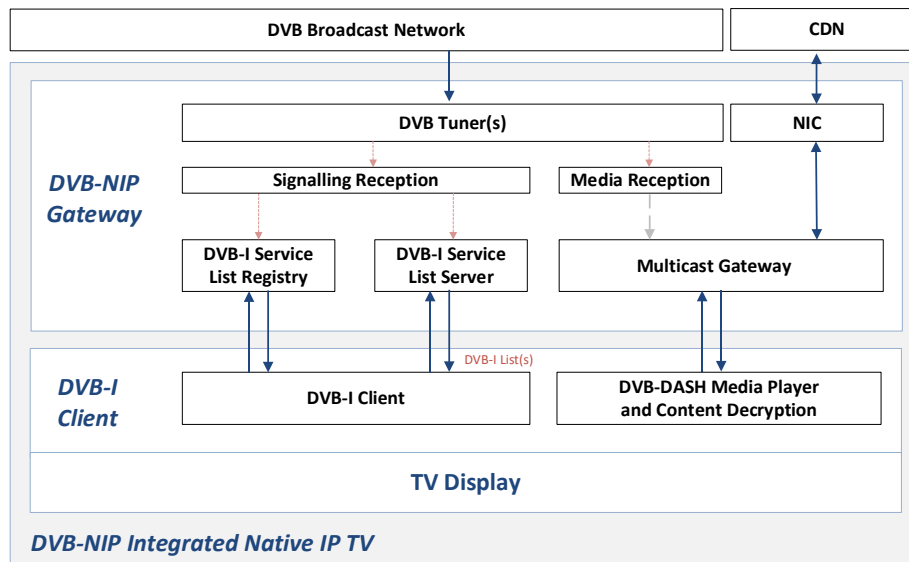

**Figure 6.4-2: DVB-NIP DM2 Integrated Native IP TV Simplified Architecture (informative)**

## 6.5 Home Gateway + IP Client (DM3)

Deployment Model 3 (DM3) is a split model in which the NIP Gateway and the NIP Client functions are implemented in separate devices.

The NIP Gateway may be an additional feature of an existing hardware device such as a TV set, a STB, an antenna multiswitch, etc. or may be a dedicated standalone Gateway device located on the local network. NIP Gateways may or may not be connected to a broadband network.

The NIP Client (typically a client implementing DVB-I according to ETSI TS 103 770 [9]) is generally a software application or component running on a tunerless smart IP device such as a tablet, smartphone, laptop, PC, IP media player, smart television set etc.

In order for a NIP Client and a NIP Gateway to discover themselves on the local network, DM3 implementations according to the present document shall make use of the Network Device Discovery Protocol mechanisms specified in clause 11.1.

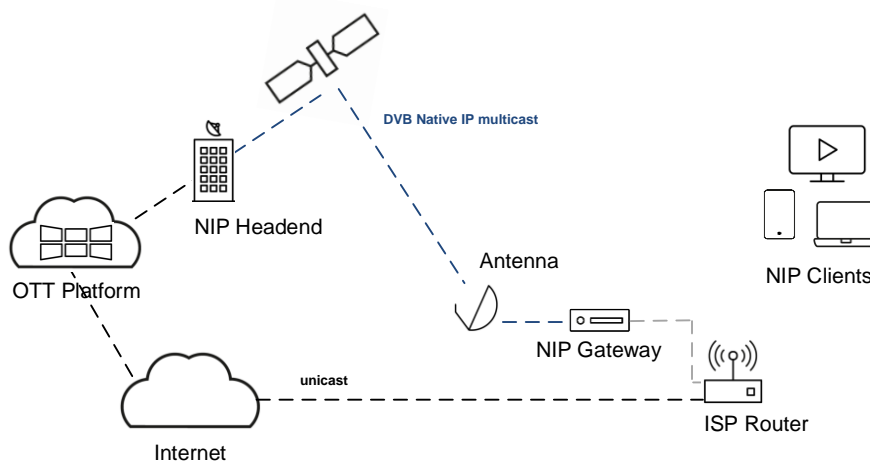

**Figure 6.5-1: Simplified view of Deployment Model 3**

In DM3 all interactions between the DVB-I client and the NIP provided DVB-I server functions shall be according to ETSI TS 103 770 [9]. The NIP specification has been designed so as to allow the use of standard unmodified DVB-I Clients also in a DVB-NIP Broadcast System.

A simplified view of the split NIP Client Gateway architecture is shown below:

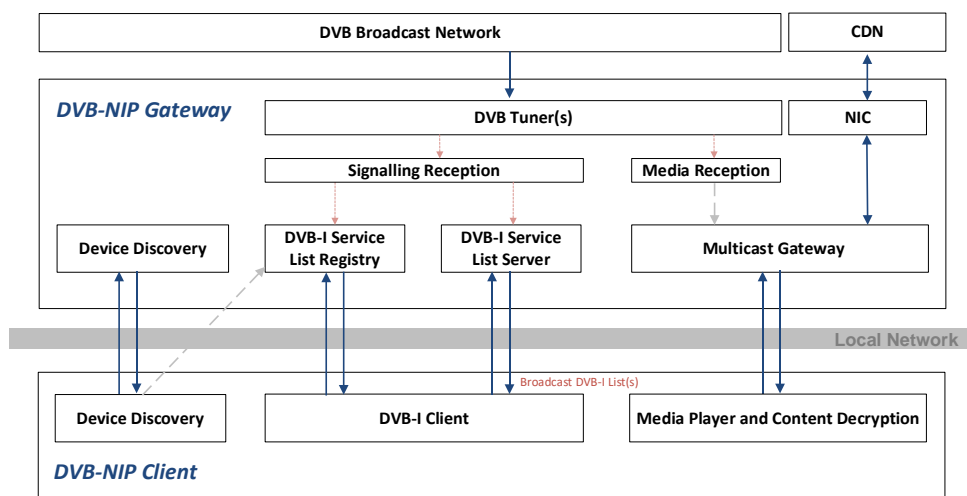

**Figure 6.5-2: DVB-NIP DM3 Split Gateway Client simplified architecture (informative)**



## 6.6 Receiver Configurations and Deployment Models

Depending on the specific deployment model, receiver configurations may require different functions and features to be implemented. The table below associates the receiver functions and the deployment models. At least "Mandatory" subsystems and functionalities shall be implemented in reception equipment to comply with the present document for a specific deployment model.

**Table 6.6-1: Receiver Configurations and Deployment Models**

Receiver configurations	DM1 NIP Edge Cache Receiver	DM2 Integrated NIP TV	DM3 NIP Gateway	DM3 NIP Client
<b>DVB-NIP Functions or Features</b>				
GSE-Lite for S2X and T2 receivers	M <sup>(1)</sup>	M <sup>(1)</sup>	M <sup>(1)</sup>	NA
GSE-HEM mode for S2X and T2 reception	M <sup>(1)</sup>	M <sup>(1)</sup>	M <sup>(1)</sup>	NA
MPE for S2	M <sup>(2)</sup>	M <sup>(2)</sup>	M <sup>(2)</sup>	NA
LL signalling	M <sup>(3)</sup>	M <sup>(3)</sup>	M <sup>(3)</sup>	NA
IP RoHC	M <sup>(3)</sup>	M <sup>(3)</sup>	M <sup>(3)</sup>	NA
Multicast rendezvous service	M	M	M	NA
Multicast gateway function	M	M	M	NA
Multicast GW, bootstrap and config file	M	M	M	NA
FLUTE and ROUTE reception	M	M	M	NA
DVB-I Service List Entry Points Registry	O	M	M	NA
DVB-I Service List Discovery	O	M	NA	M
DVB-I Service Lists	O	M	M	M
DVB-I Content Guide (connected)	O	O	O	O
Announcement Channel reception	M	M	M	NA
NIF Table	O	M	M	NA
SIF Table	O	M	M	NA
Device Discovery: UPnP	NA	NA	M	M <sup>(4)</sup>
Device Discovery: mDNS	NA	NA	M	M <sup>(4)</sup>
Content Decoding	NA	M	NA	M
Content Decryption (connected)	NA	M	NA	M
M = Mandatory, O = Optional, NA = Not Applicable, ND = Not yet defined				
NOTE 1: Not mandatory for DVB-S2 Receivers implementing only Annex A.				
NOTE 2: Mandatory only for deployments supporting Annex A.				
NOTE 3: Not mandatory for receivers only supporting Annex A.				
NOTE 4: DM3 clients shall implement at least one of the Device Discovery Protocol clauses 11.1.2 and/or 11.1.3.				

Within the present document, a number of configurations and mechanisms are defined as "Optional". Configurations and mechanisms explicitly indicated as "optional", for a given deployment model, need not be implemented in the equipment to comply with the present document. Nevertheless, when an "Optional" mode or mechanism is implemented, it shall comply with the specification as given in the present document.

## 7 Native IP Carriage

### 7.1 Introduction

DVB Native IP is designed for deployment on top of the following physical layer systems:

- DVB-S2X (ETSI EN 302 307-2 [2], ETSI EN 302 307-1 [1]),
- DVB-S2 (ETSI EN 302 307-1 [1]) and
- DVB-T2 (ETSI TS 102 755 [3]).

The data link layer in DVB Native IP uses either:

- Generic Stream Encapsulation (GSE), ETSI TS 102 606-1 [4], ETSI TS 102 606-2 [5], ETSI TS 102 606-3 [6]
- Multi-Protocol Encapsulation ETSI EN 301 192 [7], clause 7.

In the case of GSE, the GSE-Lite profile of the GSE specification (ETSI TS 102 606-1 [4], annex D) has been chosen for Native IP purposes. The particular modes and settings of the aforementioned layer 1 and layer 2 specifications to be used for DVB-NIP are described in detail in this clause.

## 7.2 Physical Layer: DVB-S2X, DVB-S2, DVB-T2

### 7.2.1 Overview

There is a high degree of commonality between DVB-S2X (ETSI EN 302 307-2 [2]), DVB-S2 (ETSI EN 302 307-1 [1]) and DVB-T2 (ETSI TS 102 755 [3]) with regards to the mode adaptation, but some settings for NIP purposes are specific to each physical layer system and hence related definitions are described separately in the following clauses 7.2.2 to 7.2.4.

The following mapping of data link layer protocols to physical layer systems applies:

- DVB-S2X: GSE (GSE-Lite profile)
- DVB-S2: MPE
- DVB-T2: GSE (GSE-Lite profile)

### 7.2.2 DVB-S2X

The entirety of DVB-S2X is defined by the two specifications ETSI EN 302 307-1 (DVB-S2, [1]) making up the core part and (ETSI EN 302 307-2 [2]) (DVB-S2X) making up the extension of and the difference to the core part. The whole physical layer system DVB-S2X can be deployed as defined by the two aforementioned specifications – with the attributes and restrictions described below:

System configurations (table 1, clause 4.3 of ETSI EN 302 307-2 [2]):

- The system configuration for Broadcast Services according to clause 4.3, table 1 of ETSI EN 302 307-2 [2] shall be used for consumer applications or applications targeting simultaneously both consumer and professional use cases. Alternatively, the system configuration for Professional Services according to clause 4.3, table 1 of ETSI EN 302 307-2 [2] shall be used for applications purely targeting professional use cases.

Mode adaptation (clauses 5.1 of ETSI EN 302 307-1 [1] and ETSI EN 302 307-2 [2], respectively)

- Physical layer slicing – see ETSI EN 302 307-1 [1], clause 5.1.5 – is applicable.
- Baseband Frame mode shall be set to High Efficiency Mode (HEM) for NIP, see ETSI EN 302 307-2 [2], clause 5.1.7. The following settings (binary indication for all) of the MATYPE-1 field of the BBHEADER have to be selected:

TS/GS: 10 (GSE-HEM)

NPD/GSE-Lite: 1 (GSE-Lite)

- Baseband frame mode shall be set to High Efficiency Mode (HEM) for NIP, see ETSI EN 302 307-2 [2], clause 5.1.7:

MODE (EXORed with CRC-8): 0000 0001 (High Efficiency Mode, HEM)

- A single Input Stream of the format GSE-HEM is transmitted.
- Since NIP makes use of GSE and HEM, ETSI EN 302 307-2 [2], clause 5.1.7 including figure 1 is applicable.
- All other BBHEADER settings are set according to the definitions in ETSI EN 302 307-1 [1] and ETSI EN 302 307-2 [2].

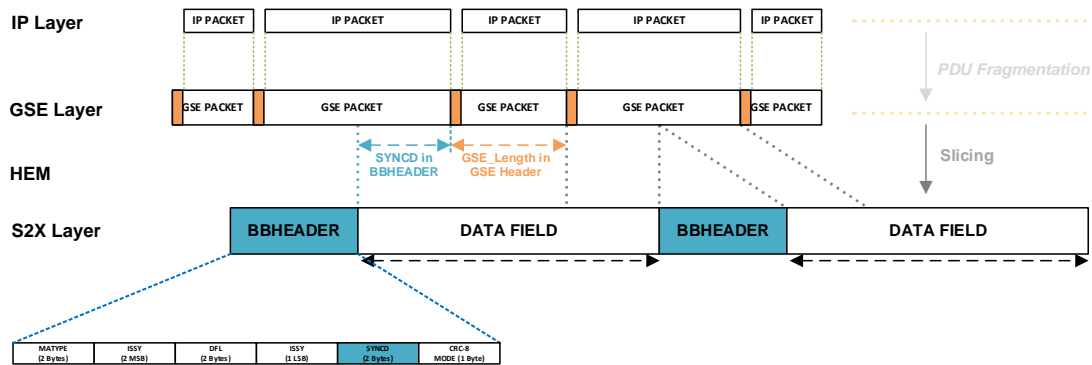

**Figure 7.2.2-1: DVB-S2X High Efficiency Mode for GSE (based on Figure 1 in ETSI EN 302 307-2 [2])**

Due to the deployment of HEM and GSE-Lite for NIP, PDU fragmentation can't be used, i.e. the only packet segmentation approach applicable is physical layer slicing.

### 7.2.3 DVB-S2

DVB-S2 is defined by the specification ETSI EN 302 307-1 [1]. The whole physical layer system DVB-S2 can be deployed as defined by the aforementioned specification – with the following attributes and restrictions:

System configurations (table 1, clause 4.3 of ETSI EN 302 307-1 [1]):

- “Broadcast Services” is used for consumer applications or applications targeting simultaneously both, consumer and professional use cases. Alternatively, the system configuration “Professional Services” shall be used for applications purely targeting professional use cases.

Mode adaptation (clause 5.1 of ETSI EN 302 307-1 [1]):

- Physical layer slicing – see ETSI EN 302 307-1 [1], clause 5.1.5 – is applicable.
- The following setting (binary indication) of the MATYPE-1 field of the BBHEADER – see ETSI EN 302 307-1 [1], clause 5.1.6, table 3, has to be selected:

TS/GS: 11 (Transport Stream)

- A single Input Stream of the format MPEG-2 Transport Stream with Constant Coding and Modulation (CCM) is transmitted. Accordingly, table 4 in ETSI EN 302 307-1 [1], clause 5.1.6, applies.
- All other BBHEADER settings are chosen according to the definitions in ETSI EN 302 307 [1].

### 7.2.4 DVB-T2

DVB-T2 is defined by the specification ETSI TS 102 755 [3]. The whole physical layer system DVB-T2 can be deployed as defined by the aforementioned specifications – with the following attributes and restrictions:

System overview (clause 4.1 of ETSI TS 102 755 [3]):

- It is assumed that the receiver will always be able to decode one data PLP and its associated common PLP – if any – in parallel. See ETSI TS 102 755 [3], clause 4.1.

Mode adaptation (clause 5.1 of ETSI TS 102 755 [3]):

- Physical layer slicing is applicable, see ETSI TS 102 755 [3], clause 5.1.0 and clause 5.1.8, figure 8.
- The following settings (binary indication for all) of the MATYPE-1 field of the BBHEADER have to be selected (see ETSI TS 102 755 [3], clause 5.1.7):

TS/GS: 10 (GSE)

NPD/GSE-Lite: 1 (GSE-Lite profile)

- Baseband frame mode shall be set to High Efficiency Mode (HEM) for NIP, see ETSI TS 102 755 [3], clauses 5.1.7 and 5.1.8:

MODE (EXORed with CRC-8): 0000 0001 (High Efficiency Mode, HEM)

- Since NIP makes use of GSE and HEM, figure 8 as part of clause 5.1.8 in ETSI TS 102 755 [3] and related text is applicable.
- All other BBHEADER settings are chosen according to the definitions in ETSI TS 102 755 [3].

Due to the deployment of HEM and GSE-Lite for NIP, PDU fragmentation can't be used, i.e. the only packet segmentation approach applicable is physical layer slicing.

## 7.3 Data link layer: GSE-Lite, MPE

### 7.3.1 Overview

Depending on the physical layer system deployed, either GSE (ETSI TS 102 606-1 [4], ETSI TS 102 606-2 [5], ETSI TS 102 606-3 [6]) with its GSE-Lite profile or MPE (ETSI EN 301 192 [7], clause 7) is used on the data link layer. Further details are outlined in clauses 7.3.2 and 7.3.3 below.

### 7.3.2 Generic Stream Encapsulation (GSE), GSE-Lite profile

On the data link layer, Generic Stream Encapsulation (GSE, ETSI TS 102 606-1 [4], ETSI TS 102 606-2 [5], ETSI TS 102 606-3 [6]) is used for NIP purposes in conjunction with the physical layer systems DVB-S2X (EN 302 307-1 [1] and EN 302 307-2) and DVB-T2 (EN 302 755 [3]). Of the two available GSE profiles, only the GSE-Lite profile (see ETSI TS 102 606-1 [4], annex D) is used for DVB-NIP as defined by the present document.

Due to the deployment of HEM and GSE-Lite for NIP, PDU fragmentation can't be used, i.e. the only packet segmentation approach applicable is physical layer slicing.

In order to avoid compatibility issues, it is recommended that NIP GSE Encapsulators / Modulators should not use the label re-use mode" (as defined in GSE standard [ETSI TS 102 606-1 v1.2.1 [4], section 4.1.3])

### 7.3.3 Multi-Protocol Encapsulation (MPE)

On the data link layer, Multi-Protocol Encapsulation (MPE, EN 301 192 [7], clause 7) shall be used for NIP purposes in conjunction with the physical layer system DVB-S2 (EN 302 307-1 [1]).

The presence of a Multiprotocol data stream in a DVB Service shall be indicated in the program map section, according to ISO/IEC 13818-1 15 of that service by setting the stream type to the value "0x0D". A given service shall not include more than one MPE section stream. However more than one service carrying an MPE section stream may be present in a given Transport Stream according to ISO/IEC 13818-1 [15]. The table\_id in the header of MPE sections shall be set to "0x3E"

LLC/SNAP is not used. Accordingly, the LLC\_SNAP\_flag field of the datagram section has the value "0" and the datagram section carries an IP datagram.

The MAC to IP mapping in NIP shall be as specified in IETF RFC 1112 [20] for IPv4 and IETF RFC 2464 [21] for IPv6 multicast addresses.

## 7.3.4 NIP Stream Definition

A DVB-NIP broadcast platform carries IP multicast data within NIP Streams. A NIP Stream is a succession of network layer IP packets that are carried via data link layer frames with no specific timing constraints. The data link layer for NIP shall be a GSE-Lite stream according to clause 7.3.2 or an MPE stream according to clause 7.3.3.

A NIP Stream is therefore identical to a GSE-Lite stream or an MPE stream.

In a single input stream DVB-S2X implementation a single GSE-Lite stream shall be carried in a single physical transponder/channel. In a multi-stream implementation, more than one GSE-Lite stream may be carried over a single physical transponder/channel. The same logic applies to single or multiple PLP DVB-T2 implementations.

In the context of DVB-S2 the NIP Stream is carried using an MPE stream declared as the sole component of a DVB Service. A Transport stream may carry more than one DVB Service carrying each a single MPE stream.

The multicast data transmitted over the broadcast channel is generated primarily by the Multicast Server, but also the NIP Signalling Server associated to each NIP Stream. Every NIP Stream shall have only a single Multicast Server associated to it. The Multicast Server generates multicast transport sessions consisting each out of one or more multicast streams.

If on a given physical channel more than one logical Multicast Server function will have to be supported, then use shall be made of the multiple input stream / PLP mechanisms as defined in the corresponding physical layer standards.

A NIP Stream is uniquely identified by the following four parameters: NIPNetworkID, NIPCarrierID, NIPLinkID, NIPServiceID.

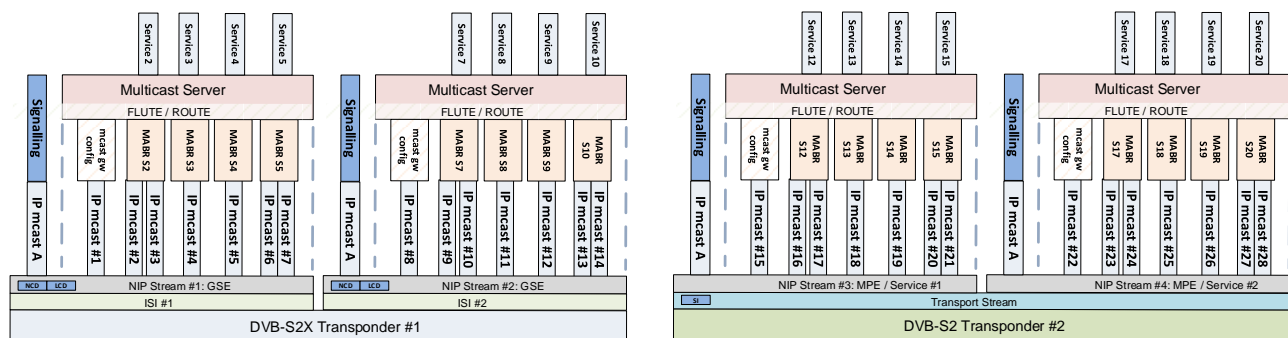

Figure 7.3.4-1: Example Illustration showing NIP Streams on GSE-Lite and MPE Transponders

## 7.4 Network Layer: IP Robust Header Compression (ROHC)

### 7.4.1 Introduction and Principles

DVB-NIP provides support for both uncompressed and compressed IP header transport. When IP header compression is used, the IP header compression scheme shall be ROHC-U as described in GSE-ROHC, ETSI TS 102 606-3 [6].

In the GSE-ROHC framework, multiple header compression profiles are defined. Each profile indicates a specific protocol combination, and the profile identifiers are allocated by the Internet Assigned Numbers Authority (IANA). For DVB-NIP, the profile '0x0002' is used for multicast streams.

In DVB-NIP, signalling information is carried through an announcement channel on a fixed IP multicast address and UDP port number. For the stable reception and fast acquisition of the announcement channel without additional processing, the announcement channel IP headers shall not be compressed.

When DVB-NIP is used in a backwards compatibility mode as described in Annex A using the MPE protocol as defined in ETSI EN 301 192 [7], IP ROHC shall not be applied.

## 7.4.2 ROHC channel mapping

The ROHC framework defines channels to identify the compressed packet flows. In a DVB-NIP system, a single ROHC channel shall be configured per GSE stream. Therefore, the Link ID can be mapped to a ROHC channel ID and the CID is managed separately for each GSE stream.

## 7.4.3 Context ID (CID) assignment

The CID can be assigned for each IP stream based on the combinations of upper layer protocols. An IP stream can be classified based on the IP address and port number. It can be considered as the same IP stream when the IP packet has the same combination of source IP address, destination IP address, source UDP port, and destination UDP port. For the same IP/UDP stream, the same CID can be assigned.

In ROHC, each ROHC channel can define three types of CID configuration: small CID, 1-byte large CID, and 2-byte large CID. Among these configurations, small CID and 1-byte large CID should be configured for DVB-NIP Systems as described in GSE-ROHC, ETSI TS 102 606-TS 102 606-3 [6].

## 7.4.4 Transmission of Context Information

In the case of unidirectional links, if a receiver has no context information, the ROHC decompressor cannot recover the received packet header until it receives full context data. The context information and configuration parameters are sent in the ROHC-U descriptor or ROHC-U multicast descriptor.

Based on the GSE-ROHC specification ETSI TS 102 606-TS 102 606-3 [6], the adaptation module at the transmitter constructs the ROHC-U descriptor or the ROHC-U multicast descriptor using configuration parameters and context information from the ROHC process. The adaptation module at the transmitter can use the previous configuration parameters and context information to transmit the ROHC-U descriptor or ROHC-U multicast descriptor periodically.

DVB-NIP supports the transmission method which sends context information separately from a compressed packet stream. The ROHC-U descriptor or ROHC-U multicast descriptor, including extracted context information, may be transmitted separately from the related ROHC packet flow, along with other signalling data. An updated ROHC-U descriptor or ROHC-U multicast descriptor shall be transmitted when the contained context information changes. The updated ROHC-U descriptor or ROHC-U multicast descriptor shall be sent prior to any GSE packets reflecting the change.

## 7.4.5 Link Layer Signalling

Generally, link layer signalling operates below the IP layer. In the receiver, link layer signalling can be obtained earlier than IP-level signalling such as announcement channel signalling.

Figure 7.4.5-1 shows the data link layer architecture and related identifiers on the transmission side of the DVB-NIP Broadcast System.



**Figure 7.4.5-1: GSE layer architecture for DVB-NIP**

NIP multicast IP streams are generated by both the Multicast Server and the NIP Signalling Server. These are shown as Data Sources in Figure 7.4.5-1 and identified each by a Multicast Stream ID. IP Multicast Streams may or may not be compressed. IP multicast streams which are compressed (`header_compression_flag=1`) pass through the IP ROHC compression module associated to that GSE Stream also referred to as GSE Stream Generator in figure 7.4.5-1. All IP multicast streams destined for a given ISI or PLP are then encapsulated in the corresponding GSE Stream. In DVB-NIP the NIPLinkID and NIPCarrierID are related as described in clause 7.3.4. The `link_id` (as defined in GSE-LLC, TS 102 606-TS 102 606-2 [5]) is identical to NIPLinkID. The NIPLinkIDs are mapped to PHY Stream IDs (as defined in 8.4.5.15 of ETSI EN 301 192 [7]) in the Link Layer. Both these identifiers are mapped to the PLP ID in the case of DVB-T2 (ETSI TS 102 755 [3]) or ISI in the case of DVB-S2 (ETSI EN 302 307-1 [1]) or DVB-S2X (ETSI EN 302 307-1 [1], ETSI EN 302 307-2 [2],) of the corresponding NIP Stream.

Link layer signalling shall be encapsulated into GSE-LLC packets as described in GSE-LLC, TS 102 606-TS 102 606-2 [5]. The GSE-LLC packet can contain multiple descriptors.

## 7.4.6 Descriptors for the NIP system

To support the GSE layer structure above and multicast delivery, the following descriptors can be used for link layer signalling in an NIP system.

- **IP Multicast List descriptor:** This descriptor conveys a list of IPv4 multicasts carried in a physical link. This descriptor also provides additional information for processing the UDP/IPv4 packets carrying the multicasts in the DVB-GSE layer. This descriptor only provides information on UDP/IPv4 multicasts.
- **IPv6 Multicast List descriptor:** This descriptor conveys a list of IPv6 multicasts carried in a physical link. This descriptor also provides additional information for processing the UDP/IPv6 packets carrying the multicasts in the DVB-GSE layer. This descriptor only provides information on UDP/IPv6 multicasts.

- ROHC-U Multicast descriptor: This descriptor conveys configuration parameters for a ROHC channel which uses ROHC for IP as defined in ETSI TS 102 606-3 [6].
- ROHC-U descriptor: This descriptor conveys configuration parameters for the single CID of ROHC as defined in ETSI TS 102 606-3 [6].

### 7.4.7 Link Layer Signalling Example (informative)

Figure 7.4.7-1 shows the construction of link layer signalling using GSE-LLC.

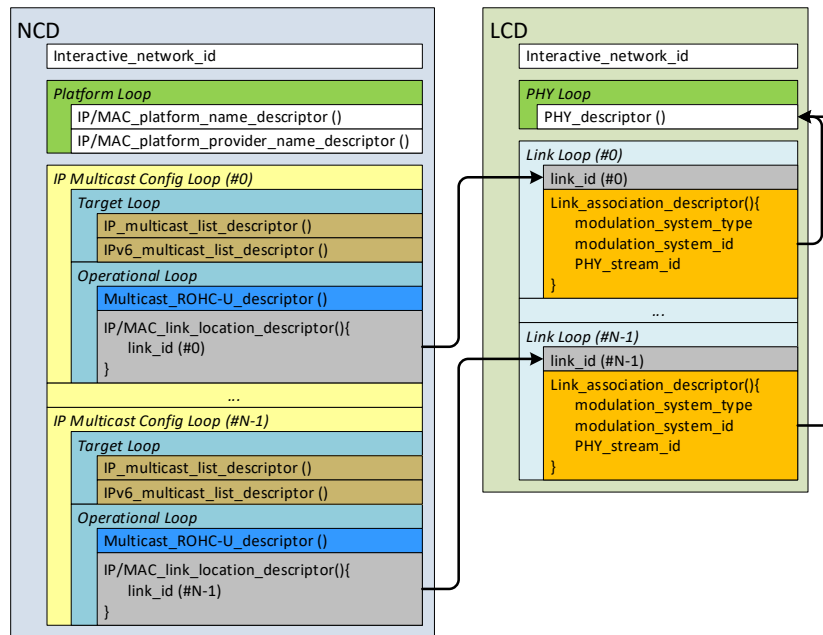

**Figure 7.4.7-1: Mapping to LLC tables and lookup path for DVB-NIP**

Multiple logical IP multicast configuration loops can be considered in a NCD record table. Each IP multicast configuration loop contains a target loop and an operational loop. Multiple descriptors can be configured in a target loop or operational loop. The IP multicast configuration loop can be constructed for each GSE stream. Each GSE stream can be identified by the link\_id in the IP/MAC\_link\_location\_descriptor.

In the target descriptor loop of NCD tables, the IP\_multicast\_list\_descriptor can be configured. If IPv4 multicast and IPv6 multicast streams are conveyed together in the same GSE stream, both the IP\_multicast\_list\_descriptor and the IPv6\_multicast\_list\_descriptor can be contained in a target descriptor loop of NCD.

In an operational descriptor loop of NCD tables, ROHC-U\_multicast\_descriptor and IP/MAC\_link\_location\_descriptor can be configured. In this case, because a single ROHC channel can be configured in a GSE stream, one Multicast\_ROHC-U\_descriptor is configured for a link\_id. If no header compression is used in a GSE stream, Multicast\_ROHC-U\_descriptor is not contained in a descriptor loop.

Each link\_id is mapped to the PHY\_stream\_id of each physical layer as configured in the LCD tables.



Figure 7.4.7-2 shows the relation between `multicast_stream_id` and `rohc_flag` in the NIP Gateway.

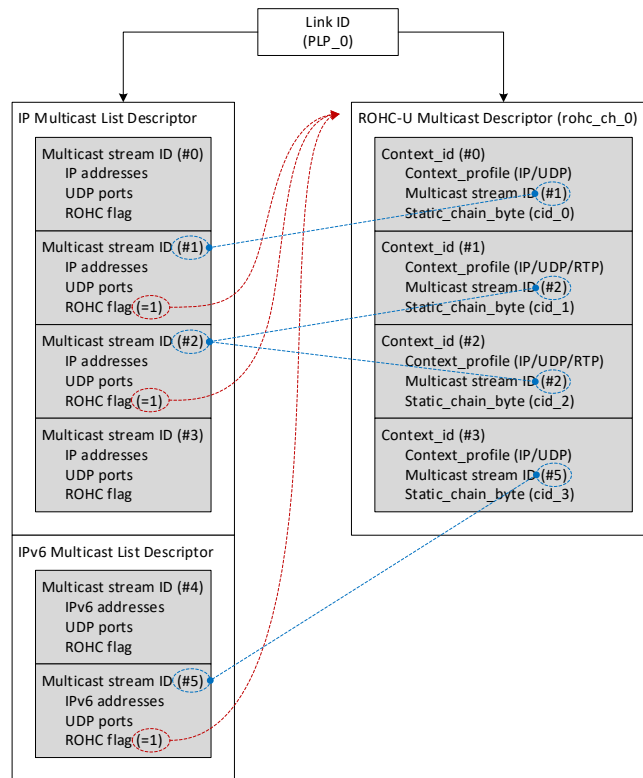

**Figure 7.4.7-2 : Multicast stream ID and ROHC flag mapping**

The multicast stream ID is assigned to each IP/UDP stream based on IP addresses and UDP port numbers. If ROHC is applied to an IP stream, the header compression flag is set for that particular IP stream. Therefore, if the header compression flag is set in the IP Multicast list descriptor, the NIP Gateway needs to check the Multicast ROHC-U descriptor for the IP stream.

When ROHC is applied to an IP stream, the multicast stream ID is mapped to a context ID for each compressed stream. Therefore, the NIP Gateway can find the context information based on the combination of multicast stream ID and context ID.

## 7.5 Transport Layer: DVB-MABR

### 7.5.1 DVB-MABR Scope

NIP according to the present document relies on DVB-MABR for the transport of Media Objects. Every NIP Stream shall have a single Multicast Server function according to ETSI TS 103 769 [8] associated with it, generating all the multicast transport objects for that NIP stream. A single logical Multicast Server function shall not span more than one NIP Stream. A physical server instantiating multiple logical Multicast Server functions may however produce multicast sessions for more than one NIP Stream.

As a consequence of this, every NIP Stream – GSE-Lite or MPE - shall carry only a single multicast gateway configuration instance document as defined in clause 8.5.2.

All protocols defined in DVB-MABR for the transport of Media Objects via multicast are applicable to DVB-NIP under the restrictions depicted in clause 8.5.

## 7.5.2 Data Plane: DVB-MABR

DVB-MABR has been specified to be independent from the underlying transport protocol. ETSI TS 103 769 [8] specifies two multicast media transport protocols in its annexes.

- The FLUTE protocol specified in annexes F and G of [8] is based on 3GPP MBMS FLUTE and may be used for the carriage of NIP Streams.
- The ROUTE-based multicast media transport protocol specified in annexes H and I of [8] is based on ATSC 3.0 ROUTE and may be used for the carriage of NIP Streams.

# 8 Service Signalling Protocols

## 8.1 Signalling Overview

### 8.1.1 Introduction

DVB-NIP Signalling, as defined in the present document, relies on the concept of a broadcast Announcement Channel carrying signalling information under the form of XML Tables to NIP receivers. The Announcement Channel mechanism is defined under clause 8.2.

### 8.1.2 Signalling Data Structures

DVB-NIP signalling information is split across 6 tables. The purpose of these tables is to inform NIP receivers about

- 1) The technical parameters required to access DVB-NIP services.
- 2) The availability of Service Lists, Services and content on the broadcast network and potentially via broadband.

The first table is called NIF: **Network Information File**. This table informs receivers about the logical identification of Streams and their physical parameters. It can be edited by the Technical Operator of the broadcast network providing an overall view of the entirety of a broadcast network or it can be edited by Commercial Operators present on that broadcast network and informing only about the Streams part of their own operations. The NIF table is carried on one or more so-called network Bootstrap Streams and is formatted as an XML file.

The second table is called SIF: **Service Information File**. This table informs receivers about the location of Services across the different NIP Streams and physical Transponders/Channels. It can be edited by the Technical Operator of the broadcast network providing an overall view of the entirety of a broadcast network or it can be edited by Commercial Operators present on that broadcast network and informing only about the location of services part of their own operations. The SIF table is carried on one or more so-called network Bootstrap Streams and is formatted as an XML file.

The third and fourth tables are related to the detailed technical operation of DVB-MABR in the context of NIP. The **Bootstrap Multicast Gateway Configuration Instance Document** is present in the announcement channel on each NIP Stream. It points to the DVB-MABR multicast session carrying the **Multicast Gateway Configuration Instance Document** as specified in DVB-MABR (ETSI TS 103 769 [8]). This latter table shall be present once on each NIP Stream and provides the link between service URLs and the IP multicast addresses in use on the broadcast Stream to convey the Services. It also provides information on other technical mechanisms available in DVB-MABR (ETSI TS 103 769 [8]) such as e.g. unicast repair mechanisms. Both tables are formatted as XML.

The fifth table is called the **DVB-I Service List Entry Points** table and provides information on the presence of DVB-I Service Lists across the broadcast network. This table is fully compliant with the DVB-I Service List Entry Points specification in ETSI TS 103 770 [9] and further described under clause 8.3.2. It is formatted as a dedicated broadcast XML file and lists the DVB-I Service Lists available.

Finally different **DVB-I Service Lists** may be provided by the Technical Operator of the network or Commercial Operators present on the network. These list the Services present on the broadcast network and provide the URLs required to access the services. DVB-I Service Lists are specified in ETSI TS 103 770 [9] and formatted as XML.

The definition and use of all these tables as defined in NIP is described in the corresponding sections below.

### 8.1.3 Service Delivery Model

A DVB-NIP broadcast network is made up of one or more RF Channels (called transponders in a satellite context). Each RF Channel can carry one or multiple input streams (ISIs) as defined in DVB-S2X (ETSI EN 302 307-1 [1], ETSI EN 302 307-2 [2]) or one or more physical layer pipes (PLPs) as defined in DVB-T2 (ETSI TS 102 755 [3]). Each input stream or physical layer pipe shall carry only a single NIP Stream encapsulated in GSE-Lite as defined under clause 7.3.2 or a single Transport Stream carrying one or more MPE streams as defined in clause 7.3.3 of the present document.

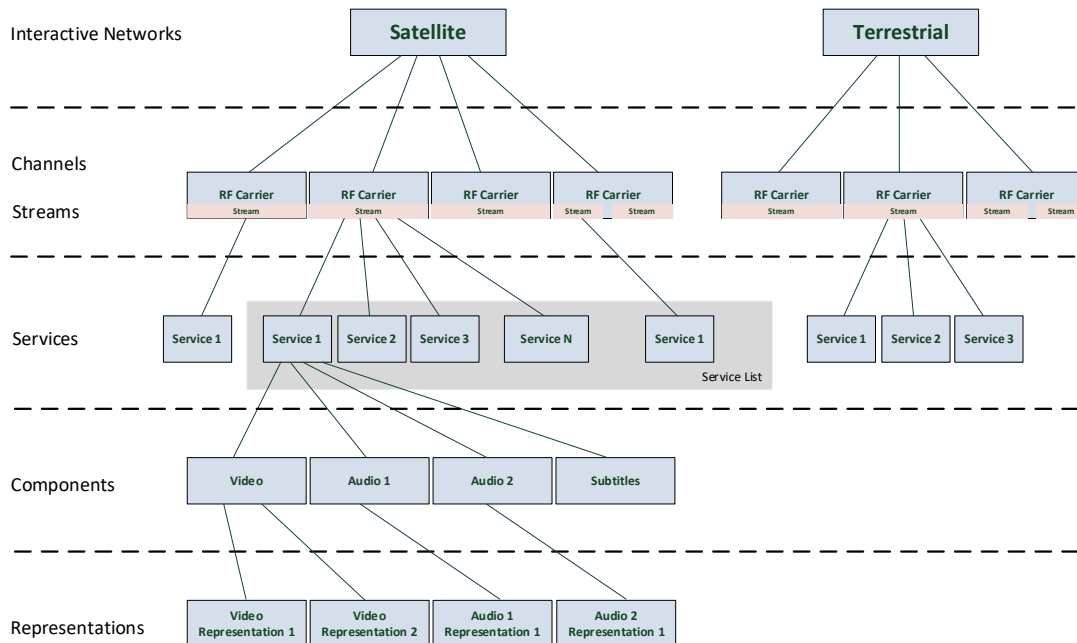

**Figure 8.1.3-1: NIP Service Delivery Model**

### 8.1.4 Bootstrap and Regular NIP Streams

#### 8.1.4.1 Definition

DVB-NIP distinguishes two types of streams: so-called Bootstrap NIP Streams and Regular NIP Streams.

Bootstrap Streams participate in the bootstrap setup phase of receivers and shall carry NIF, SIF and DVB-I Service List Entry Points. If one or more of these documents are missing, the Stream cannot be considered as Bootstrap Stream, as the receiver will not be able to discover the entirety of services.

Regular Streams do not participate in the Bootstrap Process. The Bootstrap Process helps receivers joining a network to learn about the extent of the network and the physical location of all services on that network.

#### 8.1.4.2 NIP Stream Identifiers

NIP Streams are identified by the following 4 parameters:

- NIPNetworkID identifying the network
- NIPCarrierID identifying uniquely the RF Carrier within the network identified with NIPNetworkID
- NIPLinkID identifying the NIP Stream in the context of DVB-GSE (ETSI TS 102 606-2 [5]) or in the context of DVB-S2 Professional services (ETSI EN 302 307-1 [1])
- NIPServiceID identifying the NIP Stream in the context of DVB-MPE (ETSI EN 301 192 [7])

Depending on the Data Link Layer, these respectively correspond to:

- For GSE-Lite encapsulated Streams:
  - NIPNetworkID = interactive\_network\_id as defined in ETSI TS 102 606-2 [5].
  - NIPCarrierID = modulation\_system\_id as defined in ETSI TS 102 606-2 [5].
  - NIPLinkID = link\_id<sup>(1)</sup> as defined in ETSI TS 102 606-2 [5]
  - NIPServiceID = 0 as not relevant in a GSE-Lite context.

Note <sup>(1)</sup>: In the case of single link in GSE (such as the case of Single Input Stream or unique PLP), NIPLinkID = 0.

- For MPE over TS:
  - NIPNetworkID = original\_network\_id as defined in ETSI EN 300 468 [14]
  - NIPCarrierID = transport\_stream\_id as defined in ETSI EN 300 468 [14]
  - NIPLinkID = PHY\_stream\_id<sup>(2)</sup> as defined in ETSI EN 301 192 [7]
  - NIPServiceID = service\_id as defined in ETSI EN 300 468 [14]

Note <sup>(2)</sup>: In the case of Single Input Stream or in the context of DVB-S2 Broadcast services (ETSI EN 302 307-1 [1]), NIP Link Id = 0.

## 8.1.5 Table Generation and Broadcast

DVB-NIP tables are generated as files by the NIP Service Aggregation Platform and broadcast from the NIP Headend. The Signalling Server function of a NIP Headend collects or generates the signalling information and converts it for multicast transmission via the broadcast Announcement Channel. Every NIP Stream shall carry an Announcement Channel on a fixed IP multicast address and port, as specified in clause 8.2.1 of the present document.

## 8.1.6 Signalling Broadcast Location

DVB-NIP tables are carried via the Announcement Channel mechanism described under 8.2. The Announcement Channel shall be present in every NIP Stream.

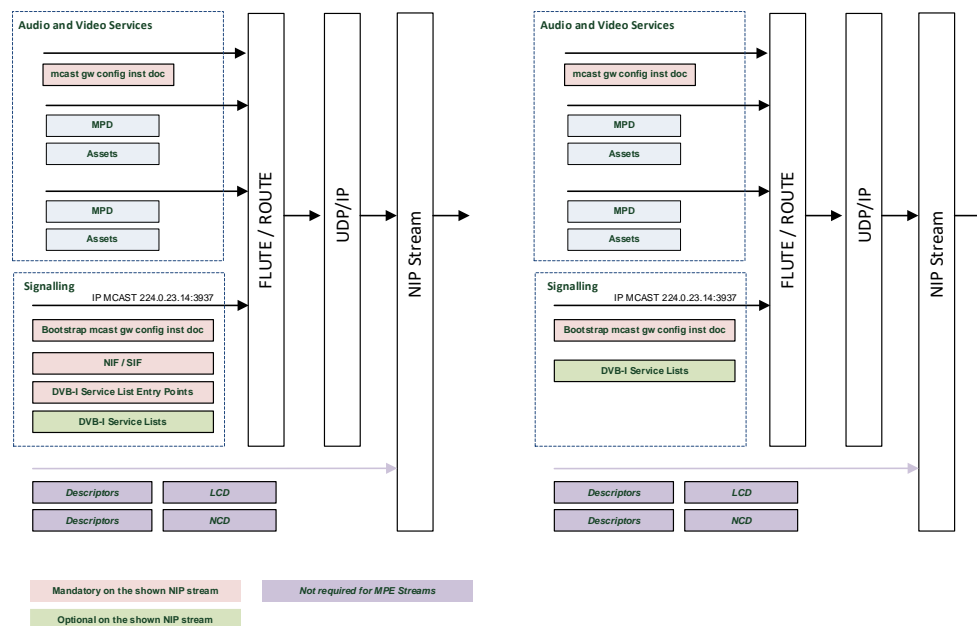

Figure 8.1.6-1: Signalling carriage in NIP Streams

The table below shows which DVB-NIP specified tables are mandatory on the Announcement Channel of the two different stream types as described in clause 8.1.4.

**Table 8.1.6-1: Possible locations of DVB-NIP Tables**

Table	Bootstrap Stream	Regular Stream
Bootstrap multicast gateway configuration instance document	M*1	M*1
NIP NIF	M	N.A.
NIP SIF	M	N.A.
DVB-I Broadcast Service List Entry Points	M	N.A.
DVB-I Broadcast Service Lists	A	A
DVB-I Playlists	O	O
NIP Time Offset Information	M	M
NIP Content Guide Manifest	O	O
NIP Content Protection Manifest	O	O
NIP Private Data Signalling	O	O
M: Mandatory O: Optional N.A.: Not Available A: Alternative but requires one		
NOTE 1: The Bootstrap multicast gateway configuration instance document is only required for Streams carrying DVB-MABR content.		

Bootstrap Streams shall carry at least the following information: NIF, SIF and the DVB-I Service List Entry Points table in addition to the “bootstrap” multicast gateway configuration instance document which is mandatory on each NIP Stream carrying DVB-MABR information, as specified in Annex C.2 of ETSI TS 103 769 [8].

## 8.1.7 Receiver Signalling Usage Sequence

### 8.1.7.1 Introduction

The clauses hereunder describe the different steps that a NIP receiver follows in order to gain access to NIP services.

### 8.1.7.2 Receiver Bootstrapping Mechanism

A NIP receiver, in idle mode, joining a NIP broadcast network initially tunes to the Bootstrap Stream and listens for the NIF, SIF tables and DVB-I Service List Service Entry Points document on the announcement channel of that stream.

A NIP Bootstrap Stream is identified thanks to:

- The NIP Stream identifiers as defined in 8.1.4.2.
- Satellite Orbital Position and West\_East\_flag (for satellite networks only).
- ProviderName.

The NIF/SIF tables inform the broadcast receiver about the location of NIP Services and other Assets available on the different physical channels of the broadcast network and how to access them through their technical parameters.

The NIP broadcast receiver then listens for the DVB-I Service List Entry Points Table. This table informs the receiver about all the DVB-I Service Lists broadcast as part of the current network.

The NIP receiver caches these 3 tables in its memory for later use.

### 8.1.7.3 Device Announcement and Discovery Mechanism

NIP receivers according to Deployment Model 3 (DM3) implement a functional split between the DVB-I Client rendering the services to end users and the NIP Gateway which receives the content from the broadcast network. NIP specifies two main mechanisms in clause 11.1 which allow both NIP Clients and NIP Gateways to announce and discover themselves while part of the same local network.

At the end of the discovery process, as specified in clause 11.1, the NIP Gateway provides the URL to the client through which the DVB-I Client can locally retrieve the DVB-I Service List Entry Points file from the Gateway.

### 8.1.7.4 DVB-I Service List Discovery Mechanism

DVB-I Clients contact the local DVB-I Service List Registry (SLR) function part of the NIP Gateway to get the DVB Service List Entry Points table. That table lists all the DVB-I Service Lists available on the broadcast network.

A DVB-I Client shall request from the NIP Gateway:

- 1.) the entire list that the Gateway received via broadcast and containing all the URLs of all the DVB-I Service Lists or
- 2.) the DVB-I Client may also include as part of its request the DVB-I defined query parameters such as “TargetCountry”, “regulatorListFlag”, “Language”, “Genre” and “ProviderName”. In such a case the NIP Gateway shall compute and return only those DVB-I Service List Entry Points corresponding to the query parameters. This functionality means that the NIP Gateway has to implement a minimum amount of DVB-I (ETSI TS 103 770 [9]) syntax to be able to filter the DVB-I Service List Entry Points table based on query parameters.

### 8.1.7.5 DVB-I Service Discovery Mechanism

Once the DVB-I Client has received the entire or down-filtered list of DVB-I Service Lists available on the broadcast network it can itself or through interaction with the end-user select the DVB-I Service List to use for the selection of DVB-I Services.

The DVB-I Client will request the selected DVB-I Service List from the NIP Gateway. If the NIP Gateway does not have the list in its cache, it will retrieve the DVB-I Service List from the broadcast stream. To locate the corresponding Service List on the broadcast network:

- the NIP Gateway shall match the URL of the DVB-I Service List (originally from the DVB-I Service List Entry Points table) with the DVB-I Service List URLs in the SIF table.
- It will then, using the NIF table, tune to the physical channel to receive the corresponding DVB-I Service List.

To improve the user experience, it is recommended for NIP Gateways to pre-cache as many of the DVB-I tables as possible.

### 8.1.7.6 Service Tuning and Service Access Mechanism

Each time the end-user selects a broadcast service instance from the DVB-I Service List, the DVB-I Client function sends a request for the MPEG-DASH manifest to the NIP Gateway function. These instance requests are automatically sent to the Gateway due to the format of the URLs for such instances.

## 8.2 Signalling Carriage Description

### 8.2.1 Principles

Every NIP GSE-Lite/MPE stream according to the present document shall carry an announcement channel on a fixed IP multicast address, UDP port number. The announcement channel shall use the FLUTE/ROUTE protocol specified in annexes F and G of [8] to carry the signalling information required for a Native IP system to operate.

The fixed IP multicast address and UDP number of the announcement channel shall never be compressed with the RoHC-U algorithm described in clause 7.4.

### 8.2.2 IP Multicast Address, Port and TSI

Signalling information shall be carried as document files in a FLUTE/ROUTE session with a well-known IP address, UDP port number and TSI (LCT) dedicated to this function.

The IP address has been registered by DVB (dvbservdsc) with IANA described in IETF RFC 5328 [19] and is 224.0.23.14 for IPv4 and FFOX:0:0:0:0:0:0:12D for IPv6.

The port number is 3937/udp.

The TSI Transport Session Identifier (LCT) value shall be set to 0.

The same IP multicast destination address shall be used in each GSE/MPE stream and care has to be taken at the headend that each GSE/MPE stream only carries the information relative to the stream in which it resides. The multicast announcement channel signalling stream only exists between the headend signalling server and the NIP Gateway Receiver function.

In addition, in order to allow NIP Gateways to detect a NIP stream change, the source IP address that carries the signalling information shall be unique for each NIP Stream.

### 8.2.3 Announcement Channel Structure

The announcement channel stream consists of a FLUTE/ROUTE session with TSI 0 using the IP multicast address and UDP port specified in clause 8.2.2.

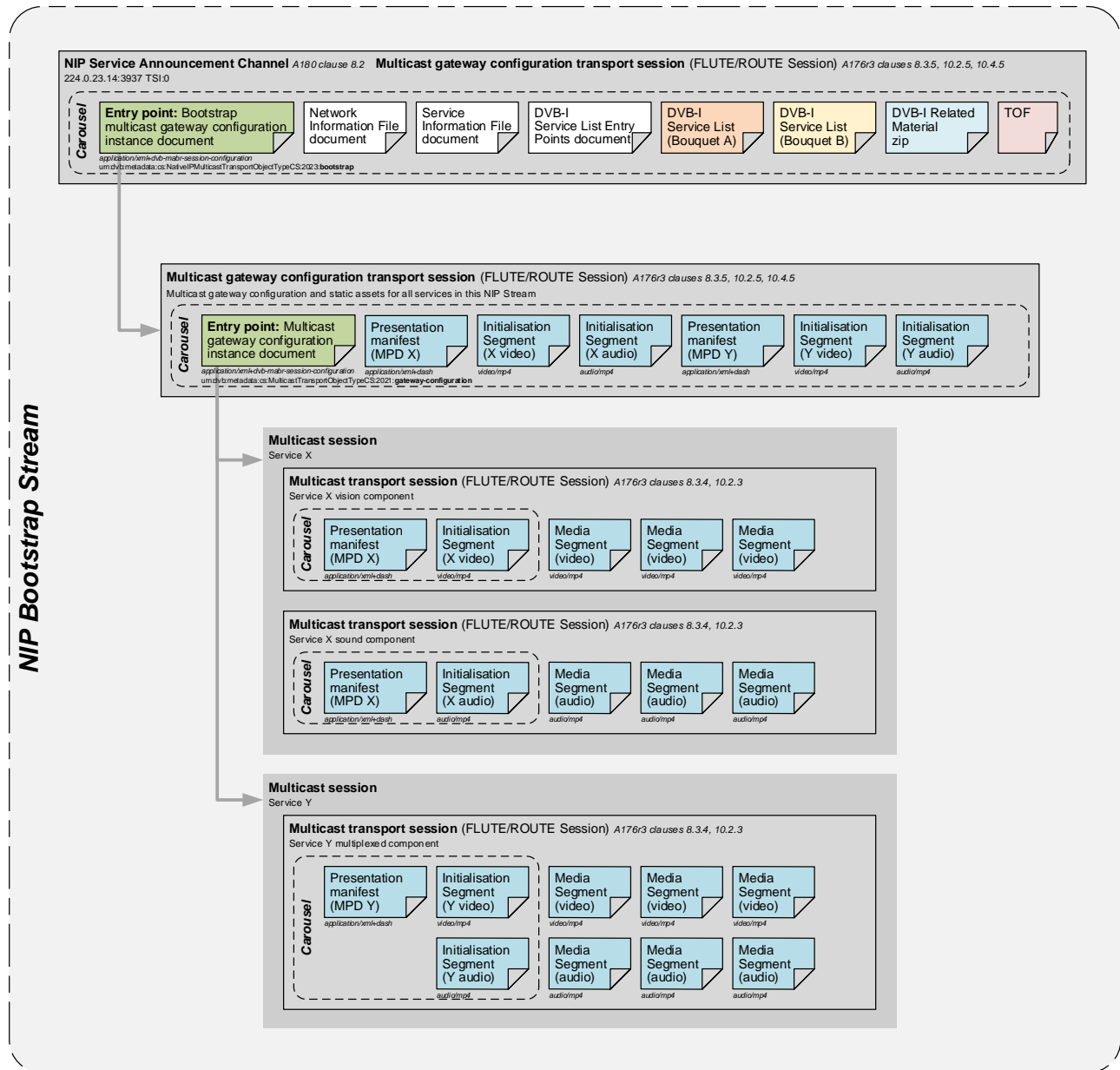

Figure 8.2.3-1 NIP Announcement Channel Example (Bootstrap Stream)

### 8.2.4 Announcement Channel FLUTE/ROUTE File Delivery Table

The announcement channel FLUTE/ROUTE session carries the mandatory FDT (File Delivery Table) as specified in RFC3926. The FDT is used to inform receivers about the files that are being transmitted and their associated metadata. FDT instances are sent in the same session as the files. The FDT itself shall always be sent in data packets with TOI=0. It is recommended to repeatedly transmit FDT instances at a rate sufficient to allow fast access for receivers to the signalling files carried in the announcement channel.

The FDT instance is an XML structure with a single root element “FDT-Instance”. For each announcement channel document file declared there is a single file description entry in the FDT instance. Each entry is declared by the element “File”. Each “File” element shall contain at least the attributes: “Content-Location”, “TOI” and “Content-Type”.

**Content-Location:** is used to convey the name of the corresponding announcement channel document file.

**TOI:** The Transport Object Identifier acts the file identifier labeling packets in the session as belonging to the transmission of a given file object.

**Content-Type:** corresponds to the Media Type (MIME type) of the corresponding document. It shall allow to uniquely identify the announcement channel files being transmitted as belonging to a certain type. The allowed values for “Content-Type” in DVB-NIP are listed in clause 8.2.5.1

```
<FDT-Instance xmlns:xsi="http://www.w3.org/2001/XMLSchema-instance"
  xsi:schemaLocation="urn:ietf:params:xml:ns:fdtietf-flute-fdt.xsd" Expires="2890842807">
  <File Content-Location="urn:dvb:metadata:cs:NativeIPMulticastTransportObjectTypeCS:2023:bootstrap" TOI="1"
  Content-Type="application/xml+dvb-mabr-session-configuration"/>
  <File Content-Location="nif.xml" TOI="2" Content-Type="application/xml+dvb-nip-nif"/>
  <File Content-Location="sif.xml" TOI="3" Content-Type="application/xml+dvb-nip-sif"/>
  <File Content-Location="dvb_i_sl_ep.xml" TOI="4" Content-Type="application/xml" />
  <File Content-Location="dvb_i_sl.xml" TOI="5" Content-Type="application/xml" />
</FDT-Instance>
```

**Figure 8.2.4-1: Example FDT (File Delivery Table)**

## 8.2.5 Announcement Channel Content

### 8.2.5.1 Payload Data

The announcement channel carries the actual signalling documents required by NIP. Signalling information is carried as different XML formatted documents among which the following:

- Bootstrap multicast gateway configuration instance document.
- NIP Network Information File.
- NIP Service Information File.
- DVB-I Broadcast Service List Entry Points.
- DVB-I Broadcast Service Lists.
- DVB-I Playlists.
- NIP Time Offset Information
- NIP Content Guide Manifest.
- NIP Content Protection Manifest
- NIP Private Data Signalling

**Table 8.2.5-1: Announcement Channel Document Media Types**

Description	Media Type (Content-Type)	URN	TOI	NIP Bootstrap Stream	NIP Regular Stream
Bootstrap multicast gateway configuration instance document	application/xml+dvb-mabr-session-configuration	urn:dvb:metadata:cs:NativeIPMulticastTransportObjectTypeCS:2023:bootstrap	Value in FDT	M	M
Multicast gateway configuration instance document	application/xml+dvb-mabr-session-configuration	urn:dvb:metadata:cs:MulticastTransportObjectTypeCS:2021:gateway-configuration	Value in FDT	M	M



NIP NIF	application/xml+dvb-nip-nif	urn:dvb:metadata:nativeip:NetworkInformationFile	Value in FDT	M	N.A.
NIP SIF	application/xml+dvb-nip-sif	urn:dvb:metadata:nativeip:ServiceInformationFile	Value in FDT	M	N.A.
Broadcast DVB-I Service List Entry Points	application/xml+dvb-i-slep	urn:dvb:metadata:servicediscovery:2022b	Value in FDT	M	N.A.
Broadcast DVB-I Service Lists	application/xml+dvb-i-sl	urn:dvb:metadata:servicediscovery:2022b	Value in FDT	A	A
Broadcast DVB-I Playlists	application/xml+dvb-i-pl	urn:dvb:metadata:servicediscovery:2022b	Value in FDT	O	O
Broadcast DVB-I Related Material	application/gzip+dvb-i-rm	urn:dvb:metadata:servicediscovery:2022b	Value in FDT	O	O
NIP Time Offset File	application/xml+dvb-nip-tof	urn:dvb:metadata:nativeip:TimeOffsetFile	Value in FDT	M	N.A.
NIP Content Guide Manifest	application/xml+dvb-nip-cgm	urn:dvb:metadata:nativeip:ContentGuideManifest	Value in FDT	O	O
NIP Content Protection Manifest	application/xml+dvb-nip-cpm	urn:dvb:metadata:nativeip:ContentProtectionManifest	Value in FDT	TBD	TBD
NIP Private Data Signalling Manifest	application/xml+dvb-nip-pds	urn:dvb:metadata:nativeip:PrivateDataSignalling	Value in FDT	M (if applicable)	N.A.
M: Mandatory O: Optional N.A.: Not Applicable A: Alternative but requires one					

### 8.2.5.2 Payload Data Updates

The semantics for any two "File" elements declaring the same "Content-Location" but differing "TOI" is that the element appearing in the FDT Instance with the greater FDT Instance ID is considered to declare a newer instance (e.g. version) of the same "File".

### 8.2.5.3 Payload Data Compression

As the signalling payload information consists of XML files which are verbose, payload data compression may be applied. If compression is applied it shall be signalled as part of the FDT. The attribute "Content-Encoding" shall be used as defined in RFC 2616. When present its value indicates what decoding mechanisms shall be applied in order to obtain the media-type referenced by the Content-Type field.

**Content-Encoding:** specifies the content encoding applied to the corresponding announcement channel document.

## 8.2.6 Announcement Channel Repetition Rates

The table below lists the minimum repetition times for each table carried via the NIP announcement channel.

**Table 8.2.6-1: Minimum table repetition rates**

Description	Table Repetition Rate (at least once every x seconds)
Bootstrap multicast gateway configuration instance document	1
NIP NIF	10
NIP SIF	10
Broadcast DVB-I Service List Entry Points	10
Broadcast DVB-I Broadcast Service Lists	10
Broadcast DVB-I Playlists	10
Broadcast DVB-I Related Material	360
NIP Time Offset File	30
NIP Content Guide Manifest	30

NIP Content Protection Manifest	30
NIP Private Data Signalling Manifest	30

## 8.3 Service Discovery and Programme Metadata: DVB-I

### 8.3.1 Overview

DVB-NIP relies on DVB-I for Service Discovery and Program Metadata as specified in ETSI TS 103 770 [9].

A DVB-NIP broadcast network according to the present document shall carry at least one DVB-I Service List listing the services available on the broadcast network. Larger broadcast networks may carry several DVB-I Service Lists. DVB-I Service Lists may be provided by the Technical Operator of the network (e.g. the satellite or terrestrial network operator) and/or by one or more Commercial Operators present on that technical network. Typically different commercial DVB-I Service Lists only carry a subset of the broadcast services available on that technical network.

### 8.3.2 DVB-I Broadcast List Discovery: Service List Entry Points

#### 8.3.2.1 Principles

For DVB-NIP Receivers to discover all the DVB-I Service Lists available on the broadcast network, the DVB-I Service List Entry Points mechanism as specified in clause 5.3 of ETSI TS 103 770 [9] shall be used.

The DVB-I Service List Entry Points mechanism is used to provide a table to NIP Receivers listing all DVB-I Service Lists of the given broadcast network. The DVB-I Service List Entry Points table shall always be broadcast as part of the signalling information on the bootstrap stream for that network.

A NIP Receiver therefore when tuned to the network bootstrap stream shall acquire the DVB-I Service List Entry Points table to learn about all the DVB-I Service Lists available on the actual network.

Note that the broadcast of the Service List Entry Points table is mandatory even when only a single DVB-I Service List table is provided on that network.

Each DVB-I table available on the broadcast network is referenced in the Service List Entry Points file through a unique URL. By matching the URL for a given Service List with the URL in the SIF table, the receiver can physically locate this table on the broadcast network and tune to the given transponder to listen for that table on the Announcement Channel.

No recommendations are made in the present document as to when the receiver shall acquire a given DVB-I Service List table listed in the Service List Entry Points table. This is normally implementation dependent and may be done automatically at start-up or only when a given client on the network requests a particular table.

The Service List Entry Points table broadcast in a DVB-NIP system shall follow the XML schema defined in clause 5.3 of ETSI TS 103 770 [9].

An example broadcast DVB-I Service List Entry Points table is shown below:

#### Listing 8.3.2.1-1: Example Broadcast List Entry Points Table

```
<?xml version="1.0" encoding="UTF-8"?>
<!DOCTYPE xml>
<!-- Example of ServiceListEntryPoint Table as broadcast over the announcement channel -->
<ServiceListEntryPoints xmlns="urn:dvb:metadata:servicelistdiscovery:2020" xmlns:xsi="http://www.w3.org/2001/XMLSchema-instance" xsi:schemaLocation="urn:dvb:metadata: servicelistdiscovery:2020 ../schemas/dvbi_service_list_discovery_v1.1.xsd" xmlns:dvbhb="urn:dvb:metadata:dvbhb-extensions:2021" xmlns:dvbisd="urn:dvb:metadata:servicediscovery:2020" xmlns:tva="urn:tva:metadata:2019">

  <ServiceListRegistryEntity>
    <Name>Satellite Europe</Name>
  </ServiceListRegistryEntity>
  <ProviderOffering>
    <Provider>
      <Name>Provider A</Name>
    </Provider>
  </ProviderOffering>
</ServiceListEntryPoints>
```

```

</Provider>
<ServiceListOffering>
  <ServiceListName>Service List A1</ServiceListName>
  <ServiceListURI contentType="application/xml">
    <dvbisd:URI>http://dvb.gw/nip/servicelist_A1.xml</dvbisd:URI>
  </ServiceListURI>
</ServiceListOffering>
<ServiceListOffering>
  <ServiceListName>Service List A2</ServiceListName>
  <ServiceListURI contentType="application/xml">
    <dvbisd:URI>http://dvb.gw/nip/servicelist_A2.xml</dvbisd:URI>
  </ServiceListURI>
</ServiceListOffering>
</ProviderOffering>
<ProviderOffering>
  <Provider>
    <Name>Provider B</Name>
  </Provider>
  <ServiceListOffering>
    <ServiceListName>Service List B1</ServiceListName>
    <ServiceListURI contentType="application/xml">
      <dvbisd:URI>http://dvb.gw/nip/servicelist_B1.xml</dvbisd:URI>
    </ServiceListURI>
  </ServiceListOffering>
</ProviderOffering>
</ServiceListEntryPoints>

```

### 8.3.2.2 DVB-I Broadcast Service List Discovery: Service List Registry Function

The Broadcast DVB-I Service List Entry Points file is multicast as a pre-compiled file (listing all the DVB-I broadcast Service Lists on the actual network) within the DVB-NIP Announcement Channel on the bootstrap stream. It is used by the Service List Registry (SLR) function part of the NIP Gateway. The Service List Registry function shall act as a local DVB-I Service List Registry (SLR) as defined in clause 5.1.3.2 of ETSI TS 103 770 [9].

The local Service List Registry function receives the Service List Entry Points table from the broadcast network and exposes the table to DVB-I clients on the network. The local Service List Registry shall accept queries from DVB-I clients.

Queries from DVB-I clients to NIP Gateways may be issued with or without query parameters as specified in ETSI TS 103 770 [9]. Query parameters may take advantage of the DVB-I's client knowledge of location or other preferences. Query Parameters defined in ETSI TS 103 770 [9] are "TargetCountry", "regulatorListFlag", "Language", "Genre" and "ProviderName". Query parameters shall be used in queries in the order presented here and as defined in clause 5.1.3.2 of ETSI TS 103 770 [9].

### 8.3.2.3 URL Coding in DVB-I Broadcast Service List Entry Points Table

In the context of NIP, DVB-I Broadcast Service Lists shall be declared in the Broadcast Service List Entry Points table using the following URL coding convention: Links towards DVB-I Broadcast Service Lists shall always be prefixed with the local domain name 'dvb.gw'.

Example of a DVB-I Broadcast Service List URL in a DVB-I Broadcast Service List Entry Point Table:

```
https://dvb.gw/service-list-provider1/international_channels.xml
```

Such local prefix shall allow NIP Gateways in split deployment models to rapidly parse and replace this particular domain name by the local IP address of a Gateway capable of serving that Service List.

The domain name "dvb.gw" cannot be publicly resolved and is only meant to be used in the context of DVB-NIP table broadcasts.

## 8.3.3 DVB-I Broadcast Service Lists

### 8.3.3.1 Introduction

Services made available via DVB-NIP compliant broadcast networks shall be signalled using the DVB-I Service List mechanism specified in section 5.5 of ETSI TS 103 770 [9]. All syntactical elements specified in ETSI TS 103 770 [9] are also available in NIP. In a DVB-NIP compliant broadcast network, DVB-I service lists are compiled by the –

Technical Operator of the network and/or - one or many Commercial Operators on that network. DVB-I Service Lists shall be broadcast on the NIP Announcement Channel as defined in clause 8.2. DVB-I Service Lists may be broadcast on any stream part of the broadcast network. The physical location of the stream carrying a particular DVB-I Service List can be found from the NIF and SIF tables described in clause 8.4.

DVB-I Service Lists broadcast on a DVB-NIP network contain services that have at least one representation or service component available on the broadcast network.

### 8.3.3.2 NIP Service Instances in DVB-I Service Lists

NIP Broadcast Services shall be declared in DVB-I Service Lists as Service instances according to 5.5.4 of ETSI TS 103 770 [9].

NIP Service declarations shall use the DVB-I declared “DASHDeliveryParametersType” as defined in 5.5.18.6 of ETSI TS 103 770 [9]. The URL within the “URIBasedLocation” shall point towards the manifest file of the service.

NIP Services are uniquely identified through their manifest URL. The manifest URL therefore acts as the **NIP Service Identifier**. The presence of a NIP Service on a broadcast network is defined by the declaration of the NIP Service Identifier in the Service Information File (SIF). Matching of the Service URL between the URL declared in the DVB-I Service List instance and the URL declared in the SIF does not take into account the optional query parameters.

The manifest of the service shall declare all representations and components of a particular service. At least one of these representations or components shall be available via broadcast and some may only be available via broadband delivery. All broadcast representations and inherent broadcast components of a service shall be broadcast within the same NIP Stream as the service manifest.

In operational situations where a particular service representation, e.g. a UHD 4K version of a service made available via broadcast, cannot be conveyed via the same NIP Stream as the other representations then it shall be declared as a different service with a separate service entry in the DVB-I broadcast Service List. The downside of this is that automatic switching between ABR representations is no longer possible.

### 8.3.3.3 URL Coding for NIP Services declared in DVB-I Broadcast Lists

NIP Broadcast Service Instances in DVB-I Service Lists shall follow the following URL convention: NIP broadcast service URLs shall always use the local domain name prefix ‘dvb.gw’.

Example of a NIP Broadcast Service URL in a DVB-I Broadcast List:

<https://dvb.gw/media.bbc.co.uk/simulcast/bbc-one/scotland/manifest.mpd>

Such local prefix, in front of the original domain, which shall be maintained, shall allow NIP receivers in split deployment models to rapidly parse and replace this particular domain name by the local IP address of a NIP Gateway capable of serving that service.

The domain name “dvb.gw” cannot be publicly resolved and is only meant to be used in the context of NIP table broadcasts.

Note that a DASH instance without the “dvb.gw” prefix means that the service is accessible to a DVB-I Client only via broadband.

The listing below shows an example of a NIP DVB-I broadcast list:

#### Listing 8.3.3.3-1: Example of NIP DVB-I broadcast list

```
<?xml version="1.0" encoding="utf-8"?>
<ServiceList xmlns="urn:dvb:metadata:servicediscovery:2019" xmlns:xsi="http://www.w3.org/2001/XMLSchema-instance"
xmlns:tva="urn:tva:metadata:2019" version="201115104525"
xsi:schemaLocation="urn:dvb:metadata:servicediscovery:2019 ../dvbi_v1.0.xsd">
  <Name>Germany FTA</Name>
  <ProviderName>SES</ProviderName>
  <RegionList version="1">
  </RegionList>
  <LCNTableList>
  </LCNTableList>
</ServiceList version="1">
```

```

<UniqueIdentifier>tag:ses.com,2019:DasErste.DasErste</UniqueIdentifier>
<!-- NIP Broadcast Instance HD and below-->
<ServiceInstance priority="1">
  <DisplayName>Das Erste HD</DisplayName>
  <SourceType>urn:dvb:metadata:source:dvb-dash</SourceType>
  <DASHDeliveryParameters>
    <UriBasedLocation contentType="application/dash+xml">
      <URI>https://dvb.gw/ard.de/dash/live/manifestDasErste.mpd</URI>
    </UriBasedLocation>
  </DASHDeliveryParameters>
</ServiceInstance>
<ServiceName>Das Erste HD</ServiceName>
<ProviderName>ARD</ProviderName>
<RelatedMaterial xsi:type="tva:RelatedMaterialType">
  <tva:HowRelated href="urn:dvb:metadata:cs:HowRelatedCS:2019:1001.2"/>
  <tva:MediaLocator>
    <tva:MediaUri contentType="image/jpeg">http://www.tv-logo.com/images/logo/ard_das_erste.jpg
  </tva:MediaUri>
  </tva:MediaLocator>
</RelatedMaterial>
<ServiceType href="urn:dvb:metadata:cs:ServiceTypeCS:2019:linear"/>
</Service>

<Service version="1">
  <UniqueIdentifier>tag:ses.com,2019:ZDF_HD.ZDF_HD</UniqueIdentifier>
  <!-- NIP Broadcast Instance HD and below-->
  <ServiceInstance priority="1">
    <DisplayName>ZDF HD</DisplayName>
    <SourceType>urn:dvb:metadata:source:dvb-dash</SourceType>
    <DASHDeliveryParameters>
      <UriBasedLocation contentType="application/dash+xml">
        <URI>https://dvb.gw/zdf.de/dash/live/manifestZDF.mpd</URI>
      </UriBasedLocation>
    </DASHDeliveryParameters>
  </ServiceInstance>
  <ServiceName>ZDF HD</ServiceName>
  <ProviderName>ZDF</ProviderName>
  <RelatedMaterial xsi:type="tva:RelatedMaterialType">
    <tva:HowRelated href="urn:dvb:metadata:cs:HowRelatedCS:2019:1001.2"/>
    <tva:MediaLocator>
      <tva:MediaUri contentType="image/jpeg">http://www.tv-logo.com/images/logo/zdf_de.jpg
    </tva:MediaUri>
    </tva:MediaLocator>
  </RelatedMaterial>
  <ServiceType href="urn:dvb:metadata:cs:ServiceTypeCS:2019:linear"/>
</Service>
</ServiceList>

```

## 8.3.4 DVB-I Content Guide Metadata

### 8.3.4.1 Connected Receivers

In the context of a NIP receiver (NIP Gateway + DVB-I Client), connected to a bidirectional broadband network, the DVB-I Content Guide metadata according to clause 6 of ETSI TS 103 770 [9] shall be queried through the IP broadband connection.

The DVB-I Content Guide Source URL shall be declared in the DVB-I Service List.

### 8.3.4.2 Unconnected Receivers

The signalling and carriage of DVB-I Content Guide metadata through broadcast means for unconnected receivers will be specified in a later revision of the present document.

## 8.4 Broadcast Network Signalling: NIF and SIF

### 8.4.1 Overview

The main purpose of Broadcast Network Signalling is to describe the broadcast network with its logical streams and their physical channel parameters and the location of services across those streams. DVB-NIP defines two tables that describe the broadcast network:

- NIF: The Network Information File provides logical and physical parameters of declared streams and channels of the broadcast network.

- SIF: The Service Information File, provides information about the location of DVB-I Service List(s), Service manifest files, interactive applications and other metadata (e.g. DVB-I Content Guide) within the logical streams on the broadcast network.

As mentioned in clause 8.1 (Signalling Overview) both NIF and SIF files shall always be present on bootstrap streams. Any stream broadcasting a NIF/SIF couple shall also carry the relevant DVB-I Service List Entry Points .xml file.

## 8.4.2 Network Information File (NIF) Definition

### 8.4.2.1 NIF Purpose

The Network Information File (NIF) describes the broadcast network. It provides information about the logical streams and physical parameters of the different RF Channels in a particular broadcast network. In that sense it is comparable to the function of the NIT in traditional DVB systems.

The NIF table also provides information on the location of bootstrap streams that help DVB-NIP receivers in the initial configuration phase.

A NIF is identified thanks to its NIPNetworkID, as specified in clause 8.1.4.2.

It is mandatory that NIF identified with the same NIPNetworkID shall be identical on any Channel of a Broadcast Network conveying such NIF.

As an option, NIF may declare Channels from any other Broadcast Network.

### 8.4.2.2 Network Information File

#### 8.4.2.2.1 NIF Schema Declaration

```
<?xml version="1.0" encoding="UTF-8"?>
<xs:schema xmlns:xs="http://www.w3.org/2001/XMLSchema" xmlns:ns="urn:dvb:metadata:nativeip:2023" xmlns:mpeg7="urn:tva:mpeg7:2008"
targetNamespace="urn:dvb:metadata:nativeip:2023" elementFormDefault="qualified">
  <xs:import namespace="urn:tva:mpeg7:2008" schemaLocation="tva_mpeg7.xsd"/>
  <xs:element name="NetworkInformationFile" type="ns:NetworkInformationFileType"/>
  ...
</schema>
```

#### 8.4.2.2.2 NetworkInformationFileType

```
<xs:complexType name="NetworkInformationFileType">
  <xs:sequence>
    <xs:element name="VersionUpdate" type="xs:dateTime"/>
    <xs:element name="NIFType">
      <xs:simpleType>
        <xs:restriction base="xs:string">
          <xs:enumeration value="Physical Network"/>
          <xs:enumeration value="Commercial Operator"/>
        </xs:restriction>
      </xs:simpleType>
    </xs:element>
    <xs:element name="ActualBroadcastNetwork" type="ns:BroadcastNetworkType"/>
    <xs:element name="OtherBroadcastNetwork" type="ns:BroadcastNetworkType" minOccurs="0" maxOccurs="unbounded"/>
  </xs:sequence>
</xs:complexType>
```

**Table 8.4.2.2-1: Network Information File Fields**

Name	Semantic Definition	Constraints
VersionUpdate	Used to provide the version number of the NIF. It indicates the date/time of modification of the latest NIF. UTC datetime formatted in Zulu Time Format (yyyy-mm-ddThh:mm:ssZ)	Mandatory
NIFType	Indicates the scope of the NIF. Only two possible values: - “Physical Network” indicates that the present NIF describes the complete physical broadcast network. Such NIF is generated by the Technical Network Operator or the Regulator. - “Commercial Operator” indicates that the present NIF describes streams carrying content for a specific Bouquet, as defined in ETSI EN 300 468 [14]. Such NIF is generated by the Commercial Network Operator or the Content Aggregator.	Mandatory
ActualBroadcastNetwork	Structure describing all NIP Streams of the Broadcast Network carrying the present NIF.	Mandatory
OtherBroadcastNetwork	Structure describing all NIF required parameters of any other Broadcast Networks. There can be as many OtherBroadcastNetwork structures as: - Different NIPNetworkID. - Different orbital position. - Different network type.	Optional 0 .. ∞

### 8.4.2.2.3 BroadcastNetworkType

```

<xs:complexType name="BroadcastNetworkType">
  <xs:sequence>
    <xs:element name="NetworkType">
      <xs:simpleType>
        <xs:restriction base="xs:string">
          <xs:enumeration value="Satellite"/>
          <xs:enumeration value="Terrestrial"/>
        </xs:restriction>
      </xs:simpleType>
    </xs:element>
    <xs:element name="NetworkName" type="xs:string"/>
    <xs:element name="NIPNetworkProviderName" type="sd:ProviderName"/>
    <xs:element name="SatellitePosition" type="ns:SatellitePositionType" minOccurs="0"/>
    <xs:element name="NIPNetworkID">
      <xs:simpleType>
        <xs:restriction base="xs:unsignedShort">
          <xs:minInclusive value="1"/>
          <xs:maxInclusive value="65280"/>
        </xs:restriction>
      </xs:simpleType>
    </xs:element>
    <xs:element name="NIPStream" type="ns:NIPStreamType" maxOccurs="unbounded"/>
  </xs:sequence>
</xs:complexType>

```

**Table 8.4.2.2.3-1: Broadcast Network Fields**

Name	Semantic Definition	Constraints
NetworkType	Indicates the type of broadcast network. Only two possible values: <ul style="list-style-type: none"> <li>- Satellite for S2/S2X</li> <li>- Terrestrial for DVB-T2</li> </ul>	Mandatory
NetworkName	The name of the network in a human readable form as Multilingual_Network_Name_descriptor as specified in ETSI EN 300 468 [14]. Multiple service list names can be specified as long as they have different @xml:lang values.	Mandatory
NIPNetworkProviderName	The name of the provider of this broadcast network. Refers to ProviderName as specified by DVB-I (ETSI TS 103 770 [9]). The operator of the NIF is the NIPNetworkProviderName declared in the Actual Broadcast Network. Formatted in a human readable form. Multiple values for the provider name can be specified as long as they have different @xml:lang values.	Mandatory
SatellitePosition	only mandatory for NetworkType = "Satellite".	Optional
NIPNetworkID	<ul style="list-style-type: none"> <li>- If LinkLayerFormat = "GSE-Lite", then this tag refers to interactive_network_id as specified in ETSI TS 102 606-2 [5]. Value in Decimal, between 1 and 65 280 (0xFF00).</li> <li>- If LinkLayerFormat = "TS", then this tag refers to original_network_id as specified in ETSI EN 300 468 [14]. Value in decimal, between 1 and 65 280 (0xFF00).</li> </ul> <p>These values correspond to the original_network_id/network_id registered at DVB Services Sàrl.</p>	Mandatory
NIPStream	Structure describing logical identifiers, physical parameters of a NIP Stream.	Mandatory 1 .. ∞



#### 8.4.2.2.4 SatellitePositionType

```
<xs:complexType name="SatellitePositionType">
  <xs:sequence>
    <xs:element name="OrbitalPosition">
      <xs:simpleType>
        <xs:restriction base="xs:double">
          <minInclusive value="0.0"/>
          <maxInclusive value="180.0"/>
        </xs:restriction>
      </xs:simpleType>
    </xs:element>
    <xs:element name="West_East_flag">
      <xs:simpleType>
        <xs:restriction base="xs:string">
          <xs:enumeration value="West"/>
          <xs:enumeration value="East"/>
        </xs:restriction>
      </xs:simpleType>
    </xs:element>
  </xs:sequence>
</complexType>
```

**Table 8.4.2.2.4-1: Satellite Position Fields**

Name	Semantic Definition	Constraints
OrbitalPosition	Value in degrees, from 0.0° to 180.0°	Mandatory
West_East_flag	Indicates if the satellite position is in the western or eastern part of the orbit.	Mandatory

#### 8.4.2.2.5 NIPStreamType

```
<xs:complexType name="NIPStreamType">
  <xs:sequence>
    <xs:element name="LinkLayerFormat">
      <xs:simpleType>
        <xs:restriction base="xs:string">
          <xs:enumeration value="GSE-Lite"/>
          <xs:enumeration value="TS"/>
        </xs:restriction>
      </xs:simpleType>
    </xs:element>
    <xs:element name="NIPStreamProviderName" type="sd:ProviderName"/>
    <xs:element name="NIPCCarrierID">
      <xs:simpleType>
        <xs:restriction base="xs:positiveInteger">
          <xs:maxInclusive value="65535"/>
        </xs:restriction>
      </xs:simpleType>
    </xs:element>
    <xs:element name="NIPLinkID">
      <xs:simpleType>
        <xs:restriction base="xs:nonNegativeInteger">
          <xs:minInclusive value="0"/>
          <xs:maxInclusive value="65535"/>
        </xs:restriction>
      </xs:simpleType>
    </xs:element>
    <xs:element name="NIPServiceID">
      <xs:simpleType>
        <xs:restriction base="xs:unsignedShort">
          <xs:minInclusive value="0"/>
          <xs:maxInclusive value="65535"/>
        </xs:restriction>
      </xs:simpleType>
    </xs:element>
    <xs:element name="BootstrapStream" minOccurs="0">
      <xs:complexType>
        <xs:sequence>
          <xs:element name="BootstrapType">
            <xs:simpleType>
              <xs:restriction base="xs:string">
                <xs:enumeration value="Physical Network"/>
                <xs:enumeration value="Commercial Operator"/>
              </xs:restriction>
            </xs:simpleType>
          </xs:element>
        </xs:sequence>
      </xs:complexType>
    </xs:element>
  </xs:sequence>
</complexType>
```

```

</xs:element>
<xs:element name="Status">
  <xs:simpleType>
    <xs:restriction base="xs:string">
      <xs:enumeration value="Active"/>
      <xs:enumeration value="Not Active"/>
      <xs:enumeration value="Deprecated"/>
    </xs:restriction>
  </xs:simpleType>
</xs:element>
</xs:sequence>
</xs:complexType>
</xs:element>
<xs:choice>
  <xs:element name="DVBS2_NIPDeliveryParameters" type="ns:DVBS2_NIPDeliveryParametersType"/>
  <xs:element name="DVBS2X_NIPDeliveryParameters" type="ns:DVBS2X_NIPDeliveryParametersType"/>
  <xs:element name="DVBT2_NIPDeliveryParameters" type="ns:DVBT2_NIPDeliveryParametersType"/>
</xs:choice>
</xs:sequence>
</xs:complexType>

```

Table 8.4.2.2.5-1: NIP Stream Fields

Name	Semantic Definition	Constraints
LinkLayerFormat	Describes the data link layer as: <ul style="list-style-type: none"> <li>- "GSE-Lite": transmission as specified in DVB GSE (ETSI TS 102 606-1 [4])</li> <li>- "TS": transmission based on MPEG-2 TS, conveying MPE services and/or MPEG/PES services.</li> </ul>	Mandatory
NIPStreamProviderName	The name of the operator of the NIPStream. It refers to ProviderName as specified by DVB-I (ETSI TS 103 770 [9]). It is possible that the NIPStreamProviderName differs from NIPNetworkProviderName.  Formatted in a human readable form. Multiple values for the provider name can be specified as long as they have different @xml:lang values.	Mandatory
NIPCarrierID	If LinkLayerFormat = "GSE-Lite", then this tag refers to modulation_system_id as specified in ETSI TS 102 606-2 [5]. Value in Decimal, between 1 and 65 535 (0xFFFF).  If LinkLayerFormat = "TS", then this tag refers to transport_stream_id as specified in ETSI EN 300 468 [14]. Value in Decimal, between 1 and 65 535 (0xFFFF).	Mandatory
NIPLinkID	If LinkLayerFormat = "GSE-Lite", then this tag refers to PHY_stream_id as specified in clause 7.4.5 of present document. Value in Decimal, between 0 and 65535 (0xFFFF).  For a single link in GSE (such as single input stream or single plp), this tag shall be set to "0".  If LinkLayerFormat = "TS", then this tag refers to PHY_stream_id as specified in clause 8.4.5.15 of ETSI EN 301 192 [7]. Value in Decimal, between 0 and 65535 (0xFFFF).  For a single input stream, this tag shall be set to "0".	Mandatory
NIPServiceID	If LinkLayerFormat = "TS", this tag refers to service_id, as specified in ETSI EN 300 468 [14], of the MPE service. Value in Decimal, between 1 and 65 535 (0xFFFF).  If LinkLayerFormat = "GSE-Lite", this tag is not used and shall be set to "0".	Mandatory
BootstrapStream	If present, the declared Stream carries the following documents: NIF, SIF, DVB-I Service List Entry Points.	Optional 0 .. ∞
BootstrapType	Indicates the scope of the NIF carried by the declared Bootstrap Stream. Two possible values: <ul style="list-style-type: none"> <li>- "Physical Network" indicates that the NIF describes the complete physical broadcast network.</li> <li>- "Commercial Operator" indicates that the NIF describes streams carrying content for a specific Bouquet, as defined in ETSI EN 300 468 [14].</li> </ul>	Mandatory

Name	Semantic Definition	Constraints
Status	Describes the bootstrap status as: <ul style="list-style-type: none"> <li>- "Active": bootstrap stream in operation</li> <li>- "Not Active": bootstrap stream not in operation (maintenance or not activated, yet)</li> <li>- "Deprecated": this is not a bootstrap stream anymore.</li> </ul>	Mandatory
DVBS2_NIPDeliveryParameters	Structure providing stream physical parameters as specified in clause 8.4.2.2.6.1.	Mandatory
DVBS2X_NIPDeliveryParameters	Structure providing stream physical parameters as in clause 8.4.2.2.6.2.	Mandatory
DVBT2_NIPDeliveryParameters	Structure providing stream physical parameters as specified in clause 8.4.2.2.6.3.	Mandatory

## 8.4.2.2.6 DeliveryParametersTypes

### 8.4.2.2.6.1 DVBS2\_NIPDeliveryParametersType

```

<xs:complexType name="DVBS2_NIPDeliveryParametersType">
  <xs:sequence>
    <xs:element name="Frequency" type="xs:positiveInteger"/>
    <xs:element name="Polarization" type="string"/>
    <xs:simpleType>
      <xs:restriction base="xs:string">
        <xs:enumeration value="horizontal"/>
        <xs:enumeration value="vertical"/>
        <xs:enumeration value="left circular"/>
        <xs:enumeration value="right circular"/>
      </xs:restriction>
    </xs:simpleType>
    <xs:element name="Modulation_Type" type="string"/>
    <xs:simpleType>
      <xs:restriction base="xs:string">
        <xs:enumeration value="QPSK"/>
        <xs:enumeration value="8PSK"/>
        <xs:enumeration value="16APSK"/>
        <xs:enumeration value="32APSK"/>
      </xs:restriction>
    </xs:simpleType>
    <xs:element name="Roll_off">
      <xs:simpleType>
        <xs:restriction base="xs:string">
          <xs:enumeration value="0.35"/>
          <xs:enumeration value="0.25"/>
          <xs:enumeration value="0.20"/>
        </xs:restriction>
      </xs:simpleType>
    <xs:element name="SymbolRate" type="positiveInteger"/>
    <xs:element name="FEC">
      <xs:simpleType>
        <xs:restriction base="xs:string">
          <xs:enumeration value="1/2"/>
          <xs:enumeration value="2/3"/>
          <xs:enumeration value="3/4"/>
          <xs:enumeration value="5/6"/>
          <xs:enumeration value="7/8"/>
          <xs:enumeration value="8/9"/>
          <xs:enumeration value="3/5"/>
          <xs:enumeration value="4/5"/>
          <xs:enumeration value="9/10"/>
        </xs:restriction>
      </xs:simpleType>
    <xs:element name="scrambling_sequence_index" minOccurs="0">
      <xs:simpleType>
        <xs:restriction base="xs:int">
          <xs:minInclusive value="0"/>
          <xs:maxInclusive value="262143"/>
        </xs:restriction>
      </xs:simpleType>
    </xs:element>
    <xs:element name="input_stream_identifier" type="unsignedByte">
  </xs:sequence>
</xs:complexType>

```

Table 8.4.2.2.6.1-1: DVBS2\_NIP Delivery Parameter Fields

Name	Semantic Definition	Constraints
Frequency	The carrier frequency expressed in units of 10 kHz.	Mandatory
Polarization	Polarization of the transmitted signal. It shall be set with one over the 4 following values, as specified in clause 6.2.13.2 of ETSI EN 300 468 [14]: <ul style="list-style-type: none"> <li>- horizontal</li> <li>- vertical</li> <li>- left circular</li> <li>- right circular</li> </ul>	Mandatory
Modulation_Type	Specifies the modulation scheme. It shall be set with one of the two following values: <ul style="list-style-type: none"> <li>- QPSK</li> <li>- 8PSK</li> <li>- 16APSK (for Professional Services)</li> <li>- 32APSK (for Professional Services)</li> </ul>	Mandatory
Roll_off	Roll-off factor shall be set with one of the 3 following values, as specified in clause 6.2.13.2 of ETSI EN 300 468 [14]: <ul style="list-style-type: none"> <li>- 0.35</li> <li>- 0.25</li> <li>- 0.20</li> </ul>	Mandatory
SymbolRate	Symbol rate value is coded in kS/s.	Mandatory
FEC	FEC value shall be set with one over the 9 following values, as specified in clause 6.2.13.2 of ETSI EN 300 468 [14]: <ul style="list-style-type: none"> <li>- 1/2</li> <li>- 2/3</li> <li>- 3/4</li> <li>- 5/6</li> <li>- 7/8</li> <li>- 8/9</li> <li>- 3/5</li> <li>- 4/5</li> <li>- 9/10</li> </ul>	Mandatory
scrambling_sequence_index	This element, when present, carries the index of the DVB-S2 physical layer scrambling sequence as defined in clause 5.5.4 of ETSI EN 302 307-1 [1].	
input_stream_identifier	Carries the DVB-S2 input_stream_identifier (ISI) as defined in clause 6.2.13.3 of ETSI EN 300 468[14].	Mandatory

## 8.4.2.2.6.2 DVBS2X\_NIPDeliveryParametersType

```

<xs:complexType name="DVBS2X_NIPDeliveryParametersType">
  <xs:sequence>
    <xs:element name="receiver_profiles">
      <xs:simpleType>
        <xs:restriction base="xs:string">
          <xs:enumeration value="Broadcast services"/>
          <xs:enumeration value="Professional services"/>
        </xs:restriction>
      </xs:simpleType>
    </xs:element>
    <xs:element name="S2X_mode">
      <xs:simpleType>
        <xs:restriction base="xs:string">
          <xs:enumeration value="S2X"/>
          <xs:enumeration value="S2X channel bonding"/>
        </xs:restriction>
      </xs:simpleType>
    </xs:element>
    <xs:element name="Frequency" type="positiveInteger" />
    <xs:element name="Polarization">

```

```

<xs:simpleType>
  <xs:restriction base="xs:string">
    <xs:enumeration value="horizontal"/>
    <xs:enumeration value="vertical"/>
    <xs:enumeration value="left circular"/>
    <xs:enumeration value="right circular"/>
  </xs:restriction>
</xs:simpleType>
</xs:element>
<xs:element name="Roll_off">
  <xs:simpleType>
    <xs:restriction base="xs:string">
      <xs:enumeration value="0.35"/>
      <xs:enumeration value="0.25"/>
      <xs:enumeration value="0.20"/>
      <xs:enumeration value="0.15"/>
      <xs:enumeration value="0.10"/>
      <xs:enumeration value="0.05"/>
    </xs:restriction>
  </xs:simpleType>
<xs:element name="SymbolRate" type="positiveInteger"/>
<xs:element name="scrambling_sequence_index" minOccurs="0">
  <xs:simpleType>
    <xs:restriction base="xs:int">
      <xs:minInclusive value="0"/>
      <xs:maxInclusive value="262143"/>
    </xs:restriction>
  </xs:simpleType>
</xs:element>
<xs:element name="input_stream_identifier" type="unsignedByte"/>
</sequence>
</complexType>

```

Table 8.4.2.2.6.2-1: DVBS2X\_NIP Delivery Parameters Fields

Name	Semantic Definition	Constraints
receiver_profiles	This field indicates which receiver profiles are targeted by the stream. It shall be set to one of the following values: - Broadcast services - Professional services	Mandatory
S2X_mode	This field indicates in which DVB-S2X mode the stream is operated. It shall be set to one of the following values: - S2X - S2X channel bonding	Mandatory
Frequency	The carrier frequency expressed in units of 10 kHz.	Mandatory
Polarization	Polarization of the transmitted signal. It shall be set with one of the 4 following values, as specified in clause 6.2.13.2 of ETSI EN 300 468 [14]: - horizontal - vertical - left circular - right circular	Mandatory
Roll_off	Roll-off factor shall be set with one of the 6 following values, as specified in clause 6.4.6.5 of ETSI EN 300 468 [14]: - 0.35 - 0.25 - 0.20 - 0.15 - 0.10 - 0.05	Mandatory
SymbolRate	Symbol rate value is coded in kS/s.	Mandatory
scrambling_sequence_index	This element, when present, carries the index of the DVB-S2X physical layer scrambling sequence as defined in clause 5.5.4 of ETSI EN 302 307-2 [2].	Optional
input_stream_identifier	Carries the DVB-S2 input_stream_identifier (ISI) as defined in clause 6.4.6.5 of ETSI EN 300 468 [14].	Mandatory

NOTE: In the context of NIP the DVB-S2X TS\_GS\_S2X\_mode shall be always set to GSE High Efficiency Mode.

## 8.4.2.2.6.3 DVBT2\_NIPDeliveryParameters

## 8.4.2.2.6.3.1 DVB\_T2NIPDeliveryParametersType

```

<xs:complexType name="DVBT2_NIPDeliveryParametersType">
  <xs:sequence>
    <xs:element name="plp_id">
      <xs:simpleType>
        <xs:restriction base="xs:unsignedShort">
          <xs:minInclusive value="0"/>
          <xs:maxInclusive value="255"/>
        </xs:restriction>
      </xs:simpleType>
    </xs:element>
    <xs:element name="T2_system_id">
      <xs:simpleType>
        <xs:restriction base="xs:unsignedShort">
          <xs:minInclusive value="1"/>
          <xs:maxInclusive value="65535"/>
        </xs:restriction>
      </xs:simpleType>
    </xs:element>
    <xs:element name="long_T2_system_delivery_descriptor" type="ns:long_T2_system_delivery_descriptorType" minOccurs="0"/>
  </xs:sequence>
</xs:complexType>

```

Table 8.4.2.2.6.3.1-1: DVBT2\_NIP Delivery Parameters Fields

Name	Semantic Definition	Constraints
plp_id	it identifies uniquely a PLP within T2_System as specified in clause 6.4.6.3 of ETSI EN 300 468 [14].	Mandatory
T2_system_id	it identifies uniquely the T2 system within the DVB network as specified in clause 6.4.6.3 of ETSI EN 300 468 [14]	Mandatory

#### 8.4.2.2.6.3.2 long\_T2\_system\_delivery\_descriptorType

```

<xs:complexType name="long_T2_system_delivery_descriptorType">
  <xs:sequence>
    <xs:element name="SISO_MISO">
      <xs:simpleType>
        <xs:restriction base="xs:string">
          <xs:enumeration value="SISO"/>
          <xs:enumeration value="MISO"/>
        </xs:restriction>
      </xs:simpleType>
    </xs:element>
    <xs:element name="bandwidth">
      <xs:simpleType>
        <xs:restriction base="xs:string">
          <xs:enumeration value="8 MHz"/>
          <xs:enumeration value="7 MHz"/>
          <xs:enumeration value="6 MHz"/>
          <xs:enumeration value="5 MHz"/>
          <xs:enumeration value="10 MHz"/>
          <xs:enumeration value="1.712 MHz"/>
        </xs:restriction>
      </xs:simpleType>
    </xs:element>
    <xs:element name="guard_interval">
      <xs:simpleType>
        <xs:restriction base="xs:string">
          <xs:enumeration value="1/32"/>
          <xs:enumeration value="1/16"/>
          <xs:enumeration value="1/8"/>
          <xs:enumeration value="1/4"/>
          <xs:enumeration value="1/128"/>
          <xs:enumeration value="19/128"/>
          <xs:enumeration value="19/256"/>
        </xs:restriction>
      </xs:simpleType>
    </xs:element>
    <xs:element name="transmission_type">
      <xs:simpleType>
        <xs:restriction base="xs:string">
          <xs:enumeration value="2k"/>
          <xs:enumeration value="8k"/>
          <xs:enumeration value="4k"/>
          <xs:enumeration value="1k"/>
          <xs:enumeration value="16k"/>
          <xs:enumeration value="32k"/>
        </xs:restriction>
      </xs:simpleType>
    </xs:element>
    <xs:element name="other_frequency_flag" type="xs:boolean"/>
    <xs:element name="tfs_flag" type="xs:boolean"/>
    <xs:element name="cell_idType">
      <xs:complexType>
        <xs:sequence>
          <xs:element name="cell_id">
            <xs:simpleType>
              <xs:restriction base="xs:unsignedShort">
                <xs:minInclusive value="0"/>
                <xs:maxInclusive value="65535"/>
              </xs:restriction>
            </xs:simpleType>
          </xs:element>
          <xs:element name="centre_frequency">
            <xs:simpleType>
              <xs:restriction base="xs:double">
                <xs:minInclusive value="10"/>
                <xs:maxInclusive value="42949672950"/>
              </xs:restriction>
            </xs:simpleType>
          </xs:element>
        </xs:sequence>
      </xs:complexType>
    </xs:element>
  </xs:sequence>
</xs:complexType>

```

```

        </xs:restriction>
      </xs:simpleType>
    </xs:element>
    <xs:element name="cell_id_extension" minOccurs="0">
      <xs:simpleType>
        <xs:restriction base="xs:unsignedShort">
          <xs:minInclusive value="0"/>
          <xs:maxInclusive value="65535"/>
        </xs:restriction>
      </xs:simpleType>
    </xs:element>
    <xs:element name="transposer_frequency" minOccurs="0">
      <xs:simpleType>
        <xs:restriction base="xs:double">
          <xs:minInclusive value="10"/>
          <xs:maxInclusive value="42949672950"/>
        </xs:restriction>
      </xs:simpleType>
    </xs:element>
  </xs:sequence>
</xs:complexType>
</xs:element>
</xs:sequence>
</complexType>

```



Table 8.4.2.2.6.3.2-1: long\_T2\_system delivery descriptor Fields

Name	Semantic Definition	Constraints
SISO_MISO	Indicates one of the following modes: - SISO - MISO	Mandatory
bandwidth	Indicates one of the following bandwidth values: - 8 MHz - 7 MHz - 6 MHz - 5 MHz - 10 MHz - 1712 MHz	Mandatory
guard_interval	Indicates one of the following guard interval values: - 1/32 - 1/16 - 1/8 - 1/4 - 1/128 - 19/128 - 19/256	Mandatory
transmission_type	Indicates the FFT size of the signals transmitted within the associated cell. One of the following modes: - 2k - 8k - 4k - 1k - 16k - 32k	Mandatory
other_frequency_flag	This flag shall be set according to clause 6.4.6.3 of ETSI EN 300 468 [14].	Mandatory
tfs_flag	This flag shall be set according to Table 138 of ETSI EN 300 468 [14].	Mandatory
cell_id	Uniquely identifies a cell_id. Value in decimal, between 0 and 65 535. Cell_id = 0, indicates that no cell_id.	Mandatory
centre_frequency	The carrier frequency expressed in units of 10kHz.	Mandatory
cell_id_extension	Identifies a sub-cell within a cell.	Optional
transposer_frequency	Indicates the centre frequency that is used by a transposer in the sub-cell indicated. Shall be set according to clause 6.4.6.3 of ETSI EN 300 468 [14].	Optional

#### 8.4.2.2.7 NIF Example

The following NIF.xml example depicts a Satellite Technical Operator declaring:

- 2 NIP Streams belonging to the same NIPNetworkID. One of them is declared as Bootstrap Stream.
- 1 NIP Stream, on the same orbital position but with different NIPNewtorkID
- 1 NIP Streams, declared as a Bootstrap, from another orbital position.

```
<?xml version="1.0" encoding="UTF-8"?>
<NetworkInformationFile xmlns:tva="urn:tva:metadata:2019" xmlns:dvbisd="urn:dvb:metadata:servicediscovery:2023"
xmlns="urn:dvb:metadata:nativeip:2023" xmlns:xsi="http://www.w3.org/2001/XMLSchema-instance"
xsi:schemaLocation="urn:dvb:metadata:nativeip:2023 ../dvbnip.xsd">

  <VersionUpdate>2021-12-20T23:00:00Z</VersionUpdate>
  <NIFType>Physical Network</NIFType>

  <ActualBroadcastNetwork>
```

```

<NetworkType>Satellite</NetworkType>
<NetworkName>SES</NetworkName>
<NIPNetworkProviderName>SES</NIPNetworkProviderName>
<SatellitePosition>
  <OrbitalPosition>019.2</OrbitalPosition>
  <West_East_flag>East</West_East_flag>
</SatellitePosition>
<NIPNetworkID>1</NIPNetworkID>
<NIPStream>
  <LinkLayerFormat>GSE-Lite</LinkLayerFormat>
  <NIPStreamProviderName>ARD</NIPStreamProviderName>
  <NIPCarrierID>1021</NIPCarrierID>
  <NIPLinkID>0</NIPLinkID>
  <NIPServiceID>0</NIPServiceID>
  <DVBS2X_NIPDeliveryParameters>
    <receiver_profiles>Broadcast services</receiver_profiles>
    <S2X_mode>S2X</S2X_mode>
    <Frequency>1152300</Frequency>
    <Polarization>horizontal</Polarization>
    <Roll_off>0.25</Roll_off>
    <SymbolRate>22000</SymbolRate>
    <input_stream_identifier>0</input_stream_identifier >
  </DVBS2X_NIPDeliveryParameters>
</NIPStream>
<NIPStream>
  <LinkLayerFormat>TS</LinkLayerFormat>
  <NIPCarrierID>1028</NIPCarrierID>
  <NIPLinkID>0</NIPLinkID>
  <NIPServiceID>100</NIPServiceID>
  <NIPStreamProviderName>SES</NIPStreamProviderName>
  <BootstrapStream>
    <BootstrapType>Physical Network</BootstrapType>
    <Status>Active</Status>
  </BootstrapStream>
  <DVBS2_NIPDeliveryParameters>
    <Frequency>1162700</Frequency>
    <Polarization>vertical</Polarization>
    <Modulation_Type>8PSK</Modulation_Type>
    <Roll_off>0.25</Roll_off>
    <SymbolRate>30000</SymbolRate>
    <FEC>5/6</FEC>
    <input_stream_identifier>0</input_stream_identifier>
  </DVBS2_NIPDeliveryParameters>
</NIPStream>
</ActualBroadcastNetwork>
<OtherBroadcastNetwork>
  <NetworkType>Satellite</NetworkType>
  <NetworkName>SKY Deutschland</NetworkName>
  <NIPNetworkProviderName>SKY</NIPNetworkProviderName>
  <SatellitePosition>
    <OrbitalPosition>019.2</OrbitalPosition>
    <West_East_flag>East</West_East_flag>
  </SatellitePosition>
  <NIPNetworkID>133</NIPNetworkID>
  <NIPStream>
    <LinkLayerFormat>TS</LinkLayerFormat>
    <NIPStreamProviderName>SKY</NIPStreamProviderName>
    <NIPCarrierID>9</NIPCarrierID>
    <NIPLinkID>0</NIPLinkID>
    <NIPServiceID>1339</NIPServiceID>
    <DVBS2_NIPDeliveryParameters>
      <Frequency>1117100</Frequency>
      <Polarization>horizontal</Polarization>
      <Modulation_Type>8PSK</Modulation_Type>
      <Roll_off>0.20</Roll_off>
      <SymbolRate>22000</SymbolRate>
      <FEC>3/4</FEC>
      <Input_stream_identifier>0</Input_stream_identifier>
    </DVBS2_NIPDeliveryParameters>
  </NIPStream>
</OtherBroadcastNetwork>
<OtherBroadcastNetwork>
  <NetworkType>Satellite</NetworkType>
  <NetworkName>Eutelsat</NetworkName>
  <NIPNetworkProviderName>Eutelsat</NIPNetworkProviderName>
  <SatellitePosition>
    <OrbitalPosition>013.0</OrbitalPosition>

```

```

    <West_East_flag>East</West_East_flag>
  </SatellitePosition>
  <NIPNetworkID>318</NIPNetworkID>
  <NIPStream>
    <LinkLayerFormat>GSE-Lite</LinkLayerFormat>
    <NIPStreamProviderName>Eutelsat</NIPStreamProviderName>
    <NIPCarrierID>500</NIPCarrierID>
    <NIPLinkID>0</NIPLinkID>
    <NIPServiceID>0</NIPServiceID>
    <BootstrapStream>
      < BootstrapType >Physical Network</ BootstrapType >
      <Status>Active</Status>
    </BootstrapStream>
    <DVBS2X_NIPDeliveryParameters>
      <receiver_profiles>Broadcast services</receiver_profiles>
      <S2X_mode>S2X</S2X_mode>
      <Frequency>1129600</Frequency>
      <Polarization>horizontal</Polarization>
      <Roll_off>0.25</Roll_off>
      <SymbolRate>27500</SymbolRate>
      <Input_stream_identifier>0</Input_stream_identifier>
    </DVBS2X_NIPDeliveryParameters>
  </NIPStream>
</OtherBroadcastNetwork>
</NetworkInformationFile>

```

## 8.4.3 Service Information File (SIF) Definition

### 8.4.3.1 SIF Purpose

The SIF (Service Information File) describes, for each stream identified logically, the location of:

- DVB-I Service Lists,
- Service manifests
- DVB-I Playlists,
- DVB-I Content Guide Sources
- Interactive Applications not linked directly to a particular service

The SIF is one of the three mandatory tables to be broadcast on a Bootstrap Stream.

The SIF is broadcast by the operator, in charge of the Broadcast Stream. The SIF is identified through the Provider Name as defined in clause 3.1.

The operator can be:

- a Technical Network Operator.
- a Commercial Operator.
- an Aggregator.
- a Regulator.

The SIF lists, for each logically identified NIP Stream, the URLs of all Services carried by the Broadcast Network.

For each NIP Stream declared in the SIF, there shall be a corresponding entry in the NIF table carried on the same Bootstrap Stream.

The SIF table operated by an Operator on one Broadcast Network, can be broadcast on one, at least, or several NIP streams, but shall be identical on all these NIP Streams at any time.

## 8.4.3.2 Service Information File

### 8.4.3.2.1 SIF Schema Declaration

```
<?xml version="1.0" encoding="UTF-8"?>
xs:schema xmlns:xs="http://www.w3.org/2001/XMLSchema" xmlns:ns="urn:dvb:metadata:nativeip:2023" xmlns:mpeg7="urn:tva:mpeg7:2008"
targetNamespace="urn:dvb:metadata:nativeip:2023" elementFormDefault="qualified">
  <xs:import namespace="urn:tva:mpeg7:2008" schemaLocation="tva_mpeg7.xsd"/>
  <xs:element name="ServiceInformationFile" type="ns:ServiceInformationFileType"/>
  ...
</xs:schema>
```

### 8.4.3.2.2 ServiceInformationFileType

```
<xs:complexType name="ServiceInformationFileType">
  <xs:sequence>
    <xs:element name="VersionUpdate" type="xs:dateTime"/>

    <xs:element name="NIPNetworkProviderName" type="sd:ProviderName" />
    <xs:element name="BroadcastMediaStream" type="ns:BroadcastMediaStreamType" minOccurs="1" maxOccurs="unbounded"/>
  </xs:sequence>
</xs:complexType>
```

**Table 8.4.3.2.2-1: Service Information File Fields**

Name	Semantic Definition	Constraints
VersionUpdate	Used to provide the version number of the SIF. It indicates the date/time of modification of the latest SIF. UTC datetime formatted in Zulu Time Format (yyyy-mm-ddThh:mm:ssZ)	Mandatory
NIPNetworkProviderName	The name of the provider of this broadcast network.  The name of the provider of this Service Information File (SIF). Refers to ProviderName as specified by DVB-I (ETSI TS 103 770 [9]). This provider operates the NIP Stream conveying this SIF. Formatted in a human readable form. Multiple values for the provider name can be specified as long as they have different @xml:lang values.	Mandatory
BroadcastMediaStream	Structure of streams carrying content described by the present SIF.	Mandatory 1 .. ∞

NOTE: All NIP streams declared in SIF BroadcastMediaStream shall be declared in the co-located NIF

### 8.4.3.2.3 BroadcastMediaStreamType

```
<xs:complexType name="BroadcastMediaStreamType">
  <xs:sequence>
    <xs:element name="NIPNetworkID">
      <xs:simpleType>
        <xs:restriction base="xs:unsignedShort">
          <xs:minInclusive value="1"/>
          <xs:maxInclusive value="65280"/>
        </xs:restriction>
      </xs:simpleType>
    </xs:element>
    <xs:element name="NIPCarrierID">
      <xs:simpleType>
        <xs:restriction base="xs:positiveInteger">
          <xs:maxInclusive value="65535"/>
        </xs:restriction>
      </xs:simpleType>
    </xs:element>
    <xs:element name="NIPLinkID">
      <xs:simpleType>
        <xs:restriction base="xs:nonNegativeInteger">
          <xs:maxInclusive value="65535"/>
        </xs:restriction>
      </xs:simpleType>
    </xs:element>
  </xs:sequence>
</xs:complexType>
```

```
<xs:element name="NIPServiceID">
  <xs:simpleType>
    <xs:restriction base="xs:unsignedShort">
      <xs:minInclusive value="0"/>
      <xs:maxInclusive value="65535"/>
    </xs:restriction>
  </xs:simpleType>
</xs:element>
<xs:element name="BroadcastMedia">
  <xs:complexType>
    <xs:sequence>
      <xs:element name="URI" type="xs:string" minOccurs="0" maxOccurs="unbounded"/>
      <xs:element name="InteractiveApplications" type="ns:InteractiveApplicationsType" minOccurs="0" maxOccurs="unbounded"/>
    </xs:sequence>
  </xs:complexType>
</xs:element>
</xs:sequence>
</xs:complexType>
```

Table 8.4.3.2.3-1: Broadcast Media Stream Fields

Name	Semantic Definition	Constraints
NIPNetworkID	<p>If LinkLayerFormat = "GSE-Lite", then this tag refers to interactive_network_id as specified in ETSI TS 102 606-2 [5]. Value in Decimal, between 1 and 65 280 (0xFF00).</p> <p>If LinkLayerFormat = "TS", then this tag refers to original_network_id as specified in ETSI EN 300 468 [14]. Value in Decimal, between 1 and 65 280 (0xFF00).</p> <p>These values correspond to the original_network_id/network_id registered at DVB Services Sàrl.</p>	Mandatory
NIPCarrierID	<p>If LinkLayerFormat = "GSE-Lite", then this tag refers to S2_system_id or T2_system_id as specified in ETSI TS 102 606-2 [5]. Value in Decimal, between 1 and 65 535 (0xFFFF).</p> <p>If LinkLayerFormat = "TS", then this tag refers to transport_stream_id as specified in ETSI EN 300 468 [14]. Value in Decimal, between 1 and 65 535 (0xFFFF).</p>	Mandatory
NIPLinkID	<p>If LinkLayerFormat = "GSE-Lite", then this tag refers to refers PHY_stream_id as specified in clause 7.4.5 of present document.</p> <p>Value in Decimal, between 0 and 65535 (0xFF). For a single input stream or single plp, this tag shall be set to "0".</p> <p>If LinkLayerFormat = "TS", then this tag refers to Input Stream Identifier as specified in clause 6.2.13.3 of ETSI EN 300 468 [14], for DVB-S2 (ETSI EN 302 307-1 [1]). Value in Decimal, between 0 and 65535 (0xFF). For a single input stream, this tag shall be set to "0".</p>	Mandatory
NIPServiceID	<p>If DataLinkFormat = "TS", this tag refers to ServiceID, as specified in ETSI EN 300468 [14], of the MPE service carrying the BroadcastMedia or InteractiveApplications. Value in Decimal, between 1 and 65 535 (0xFFFF).</p> <p>If DataLinkFormat = "GSE-Lite", this tag is not used and can be set to "0".</p>	Mandatory
BroadcastMedia	Structure describing the URL of Services and/or Interactive Applications carried by the declared NIP Stream broadcast on the current stream.	Mandatory
URI	<p>Any Media Content URL such as:</p> <ul style="list-style-type: none"> <li>- .../DVB-I_ServiceList.xml</li> <li>- .../DVB-I_ContentGuideSC.xml</li> <li>- .../Service_manifest.mpd</li> <li>- .../Service_manifest.m3u8</li> <li>- ...</li> </ul> <p>This URL shall point to the local NIP Gateway with the Local Network Domain "dvb.gw" as specified in clause 8.3.2.3.</p>	Optional 0 .. ∞
InteractiveApplications	structure describing interactive applications parameters carried by the NIP stream.	Optional 0 .. ∞

#### 8.4.3.2.4 Interactive Applications signalling structure

Interactive applications signalled in a SIF are specific to operators, identified with their ProviderName, e.g: HbbTV OpApp.

Such signalling cannot be used to declare interactive applications linked to a NIP Service, as such mechanism is specified by DVB-I (ETSI TS 103 770 [9]).

```
<xs:complexType name="InteractiveApplicationsType">
  <xs:sequence>
    <xs:element name="ApplicationType">
      <xs:simpleType>
        <xs:restriction base="xs:string">
          <xs:enumeration value="HbbTV"/>
          <xs:enumeration value="MHP"/>
          <xs:enumeration value="MHEG5"/>
          <xs:enumeration value="Proprietary"/>
        </xs:restriction>
      </xs:simpleType>
    <xs:element name="ApplicationID" type="Integer" />
    <xs:element name="ApplicationURI" type="xs:string" />
  </xs:sequence>
</xs:complexType>
```

**Table 8.4.3.2.4-1: Service Information File Fields**

Name	Semantic Definition	Constraints
ApplicationType	ApplicationType as defined in ETSI EN 300 468 [14] Or any Proprietary application type.	Mandatory
ApplicationID	Application_id as defined in ETSI EN 300 468 [14] or Proprietary application identifier.	Mandatory
ApplicationURI	Interactive application URL This URL shall point to the local NIP Gateway and shall be labelled the Local Network Domain as dvb.gw/	Mandatory

#### 8.4.3.4.5 SIF Example

The following SIF.xml example depicts a Satellite Technical Operator declaring:

- 9 broadcast streamed services over 3 NIP streams, from 3 different Providers
- 3 DVB-I Service Lists over 2 NIP Streams
- 1 DVB-I Content Guide Source
- 1 HbbTV Op App

```
<?xml version="1.0" encoding="utf-8"?>
<ServiceInformationFile xmlns="urn:dvb:metadata:nativeip:2022">
<VersionUpdate>2021-12-20T22:00:00Z</VersionUpdate>
<NIPNetworkProviderName>SES</NIPNetworkProviderName>
  <BroadcastMediaStream>
    <NIPNetworkID>1</NIPNetworkID>
    <NIPCarrierID>1028</NIPCarrierID>
    <NIPLinkID>0</NIPLinkID>
    <NIPServiceID>100</NIPServiceID>
    <BroadcastMedia>
      <URI>https://dvb.gw/SES_1_ServiceList#A.xml</URI>
      <URI>https://dvb.gw/SES_1_ServiceList#B.xml</URI>
      <URI>https://dvb.gw/SES_1_ContentGuide.xml</URI>
      <URI>https://dvb.gw/ses.com/1/CNN_International_Europe.mpd</URI>
    </BroadcastMedia>
  </BroadcastMediaStream>
<BroadcastMediaStream>
```

```

<NIPNetworkID>1</NIPNetworkID>
<NIPCarrierID>1021</NIPCarrierID>
<NIPLinkID>0</NIPLinkID>
<NIPServiceID>0</NIPServiceID>
<BroadcastMedia>
  <URI>https://dvb.gw/ARD-digital.de/live-streaming/ARD_ServiceList.xml</URI>
  <URI>https://dvb.gw/ARD-digital.de/live-streaming/WDR_Fernsehen_Köln.mpd</URI>
  <URI>https://dvb.gw/ARD-digital.de/live-streaming/WDR_Studio_Bonn.mpd</URI>
  <InteractiveApplications>
    <ApplicationType>HbbTV</ApplicationType>
    <ApplicationID>12</ApplicationID>
    <ApplicationURI>https://dvb.gw/ARD_Op_App_ait.xml</ApplicationURI>
  </InteractiveApplications>
</BroadcastMedia>
</BroadcastMediaStream>

<BroadcastMediaStream>
  <NIPNetworkID>133</NIPNetworkID>
  <NIPCarrierID>9</NIPCarrierID>
  <NIPLinkID>0</NIPLinkID>
  <NIPServiceID>1339</NIPServiceID>
  <BroadcastMedia>
    <URI>https://dvb.gw/sky.de/livestreaming/sky_one.mpd</URI>
    <URI>https://dvb.gw/sky.de/livestreaming/sky_one.m3u8</URI>
    <URI>https://dvb.gw/sky.de/livestreaming/sky_comedy.mpd</URI>
    <URI>https://dvb.gw/sky.de/livestreaming/sky_comedy.m3u8</URI>
    <URI>https://dvb.gw/sky.de/livestreaming/sky_sport.mpd</URI>
    <URI>https://dvb.gw/sky.de/livestreaming/sky_sport.m3u8</URI>
  </BroadcastMedia>
</BroadcastMediaStream>
</ServiceInformationFile>

```



## 8.5 DVB-MABR Adaptation and Signalling

### 8.5.1 Introduction

The present document relies on the DVB Multicast ABR specification (ETSI TS 103 769 [8]) for transporting ABR-coded Media Objects via multicast streaming over the DVB-NIP Broadcast System.

Figure 8.5.1-1, extracted from ETSI TS 103 769 [8] represents the DVB MABR simplified architecture. This clause describes a unidirectional deployment model and depicts signalling arrangements between the Multicast Server and the Multicast Gateway.

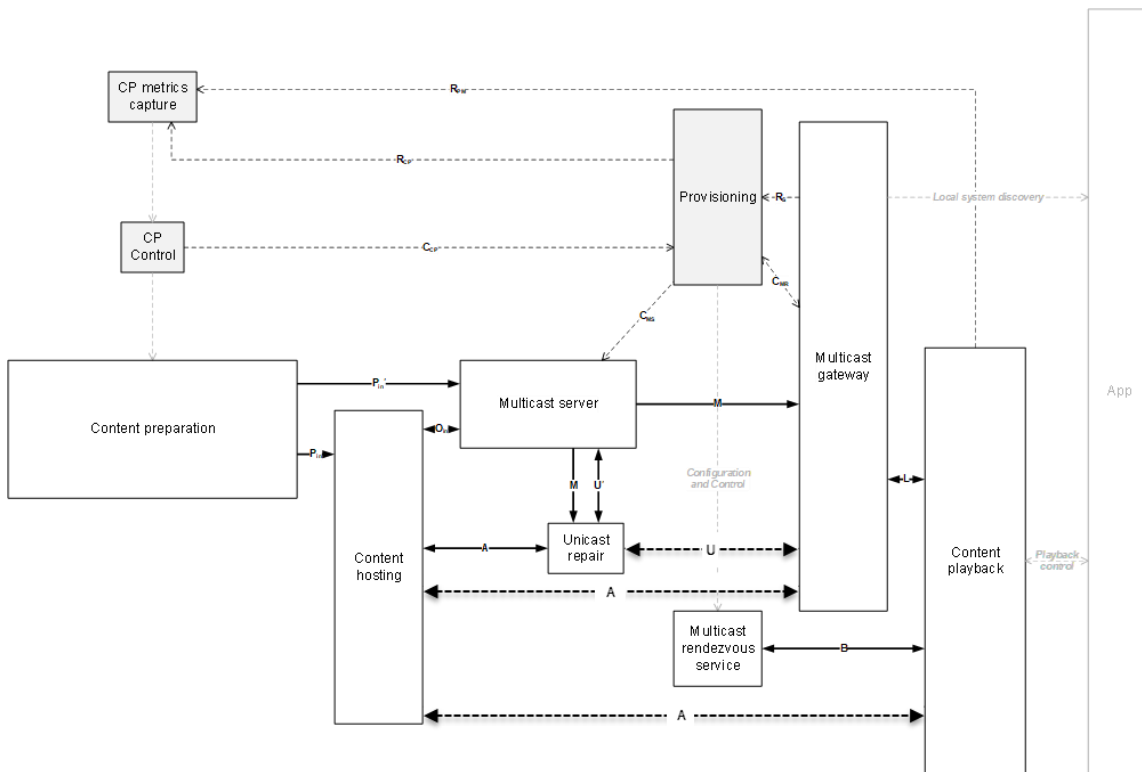

**Figure 8.5.1-1: Simplified DVB-MABR reference architecture**

The unidirectional deployment models defined in clauses 6.2 and 6.3 of ETSI TS 103 769 [8] are applicable to DVB-NIP.

- Clause 6.2 of ETSI TS 103 769 [8] corresponds to Deployment Model DM3 as described in clause 6.5 of the present document.
- Clause 6.3 of ETSI TS 103 769 [8] corresponds to Deployment Model DM2 as described in clause 6.4 of the present document.

Reference point A is optional meaning that the Multicast Gateway may not be able to access the Content hosting function through a bidirectional (unicast) access network. Similarly, the Content playback function may not be able to access the Content hosting function via reference A. Reference point CMR is not available in the absence of a bidirectional (unicast) access network

### 8.5.2 Multicast Gateway Configuration

#### 8.5.2.1 General

The Multicast Gateway is configured through at least one of the four methods defined in clause 10.1.2 of ETSI TS 103 769 [8]. In unidirectional NIP deployments, the Multicast Gateway configuration shall be provided through either the in-band method or the just-in-time method.

The multicast gateway configuration instance document is specified in clause 10.2.1.2 of ETSI TS 103 769 [8].

In the present document, the multicast session itself is identified by the *PresentationManifestLocator URL* (the URL of the manifest).

A multicast session is associated with a NIP Service that is also identified by the @serviceIdentifier attribute (clause 10.2.2 of ETSI TS 103 769 [8]) that shall correspond to the DVB-I service UniqueIdentifier as specified in clause 5.5.2. of ETSI TS 103 770 [9].

As specified in clause 7.5, the *multicast gateway configuration instance document* signals only information about the multicast transport sessions carried over the same NIP Stream (see clause 7.3.4).

As a consequence, as stated in clause 8.3.5 and clause 10.1.2 of ETSI TS 103 769 [8], there shall be one *multicast gateway configuration transport session* and one *multicast gateway configuration instance document* per NIP Stream.

### 8.5.2.2 Bootstrapping: Bootstrap Multicast Gateway Configuration Instance Document

The multicast gateway configuration instance document is transported over a specific multicast gateway configuration transport session as specified in clause 8.3.5 of ETSI TS 103 769 [8]. The characteristics of this specific transport session are declared in the “bootstrap” multicast gateway configuration instance document depicted in clause 10.2.5 of ETSI TS 103 769 [8]. This document shall be carried as part of the NIP Gateway signalling information on the Announcement Channel specified in clause 8.2 of the present document.

An example of a “bootstrap” multicast gateway configuration instance document is shown below:

```
<?xml version="1.0" encoding="UTF-8"?>
<MulticastGatewayConfiguration xmlns="urn:dvb:metadata:MulticastSessionConfiguration:2019"
xmlns:xsi="http://www.w3.org/2001/XMLSchema-instance" validityPeriod="PID">
  <MulticastGatewayConfigurationTransportSession transportSecurity="integrityAndAuthenticity">
    <TransportProtocol protocolIdentifier="urn:dvb:metadata:cs:MulticastTransportProtocolCS:2019:FLUTE" protocolVersion="1"/>
    <EndpointAddress>
      <NetworkSourceAddress>10.1.100.1</NetworkSourceAddress>
      <NetworkDestinationGroupAddress>232.98.1.1</NetworkDestinationGroupAddress>
      <TransportDestinationPort>9999</TransportDestinationPort>
      <MediaTransportSessionIdentifier>1</MediaTransportSessionIdentifier>
    </EndpointAddress>
    <BitRate maximum="200000"/>
  </MulticastGatewayConfigurationTransportSession>
</MulticastGatewayConfiguration>
```

### 8.5.3 DVB-MABR Operation and Workflow

The *NIP Gateway* shall instantiate a *Multicast Gateway* and *Multicast Rendezvous Service* as specified in clause 7.2 of ETSI TS 103 769 [8] and these instantiations shall be compliant with the following specification.

The *NIP Gateway* shall follow the mode of operation specified in clause 7.2 of ETSI TS 103 769 [8]. The following description takes precedence over the steps described in clause 7.2 of ETSI TS 103 769 [8] in case of conflicting statements.

Figure 8.5.3-1 is an adaptation of figure 7.2-1 from ETSI TS 103 769 [8] with the *NIP Gateway* featuring a co-located *Multicast Gateway* and *Multicast Rendezvous Service*, and the *NIP Client* featuring a co-located *DVB-I Client* and *Content playback* function.

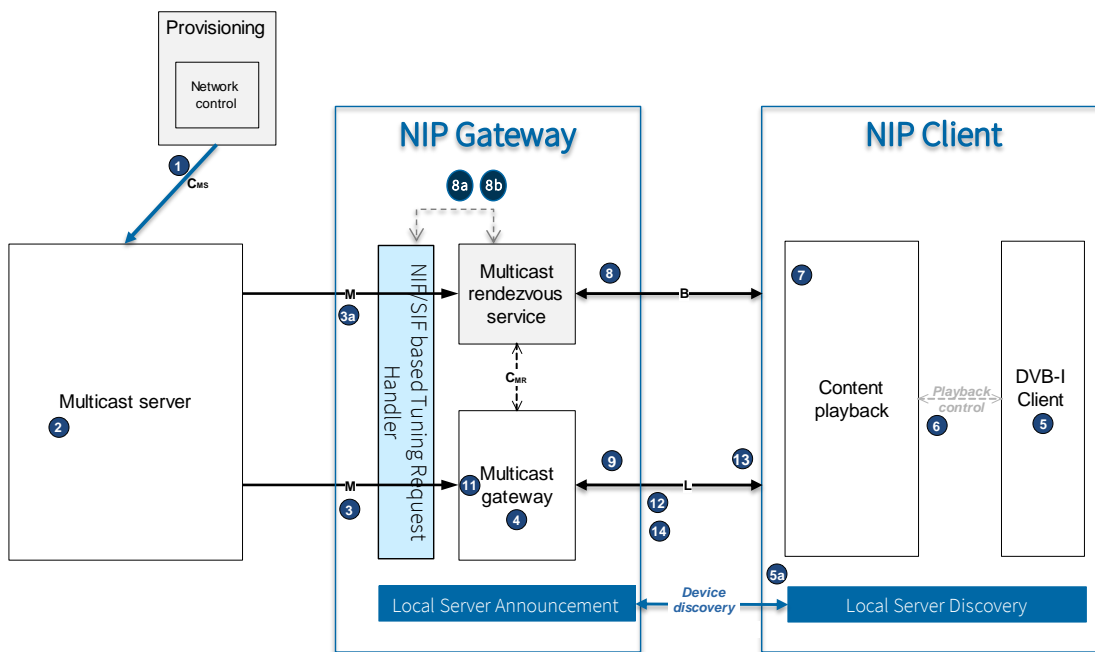

**Figure 8.5.3-1: Co-located deployment workflow**

The steps are as follows:

- 1) The *Network control* subfunction configures the *Multicast server* with the current provisioned set of multicast sessions. The *Multicast server* producing the multicast gateway configuration instance document shall take into account the constraints defined in clause 8.5.2 above.
- 2) The *Multicast server* acquires the presentation manifest and media segments, per the corresponding step in clause 7.2 of ETSI TS 103 769 [8].
- 3) The *Multicast server* sends the presentation manifest(s) as well as the media segments over the *NIP Broadcast Network* according to the multicast server configuration. Each *NIP Stream* conveys one multicast gateway configuration instance document describing the presentation manifests and all media segments carried on that *NIP Stream*.
  - a. The *Multicast server* also sends the multicast gateway configuration instance document in a dedicated multicast gateway configuration transport session at reference point **M**, per the corresponding step in clause 7.2 of ETSI TS 103 769 [8].
  - b. The *Multicast server* may send the manifest and segment initialization files over the dedicated multicast gateway configuration transport session at reference point **M**.
- 4) The *Multicast gateway* is active and discoverable by the *NIP Client* (see clause 11.1).
  - a. The *NIP Client* may discover the *NIP Gateway* by means of local system discovery (see clause 11.1). It can associate the IP address and port number with the *Multicast Rendezvous Service*.
  - b. The *DVB-I Service List Entry Points* and the *DVB-I Service Lists* shall be exposed by the *NIP Gateway* (see clause 8.3) and are therefore accessible by the *DVB-I Client*.
  - c. The *NIP Gateway* shall be capable of handling the associations between this *DVB-I Service List*, the *Service manifest URLs* and the *Service Information file (SIF)* described in clause 8.4.3.

- 5) Once a service has been selected from the DVB-I Service List (ETSI TS 103 770 [9]) exposed by the *NIP Gateway* (see clause 8.3), the *DVB-I Client* obtains the URL of the presentation manifest listed in the selected DVB-I service instance.
- a. The presentation manifest URL shall refer to the *Multicast Rendezvous Service* co-located with the Multicast Gateway.
  - b. The URL shall follow the following syntax (the *serviceId* parameter is optional).  
`http[s]://<NIP Gateway host name>:<Multicast Rendezvous Service port number>://<original targeted domain name>/<manifest path>/<manifest name>[?serviceId=<DVB-I service identifier>]`
- 6) The *NIP Client* launches the *Content playback* function (i.e. the media player) with the presentation manifest URL.
- a. The URL shall refer to the *Multicast Rendezvous Service* co-located with the *Multicast Gateway*.
  - b. The URL may include the optional request query parameters specified in clause 7.5.1 of ETSI TS 103 769 [8].
  - c. The URL may optionally include the DVB-I service identifier as an additional query parameter as specified in step 5b above. For example:  
`“https://my.dvb.gw/media.bbc.co.uk/simulcast/bbc-one/scotland/HDmanifest.mpd?serviceId=tag:bbc?co.uk:2021-12:bbc-one:scotland”.`

NOTE: The *DVB-I Client* may get the presentation manifest either directly from the DVB-I Service instance (*NIP Service Identifier*) as indicated in the previous step or by any other means.

- 7) The *Content playback* function resolves the host name (if any) of the *Multicast Rendezvous Service*.

NOTE: In the case where a domain name is to be resolved, it is assumed that the lookup is processed through a suitable mDNS server located in the *NIP Gateway* conforming to clause 11.1.3.2.

- 8) The *Content playback* function sends an HTTP(S) request to the *Multicast Rendezvous Service* over reference point **B** with the presentation manifest URL corresponding to the selected DVB-I service instance.
- a. The *Multicast Rendezvous Service* relies on the Service Information File (SIF; see clause 8.4) to check whether the service is provided via broadcast (the SIF and NIF tables associate the MPD URL with a NIP Stream on a physical RF Carrier).
    - i. The *Multicast Rendezvous Service* shall compute the NIP Service Identifier from the received requested manifest URL according to the following:
      - Starts the URL with the received URL scheme and adds the prefix “dvb.gw”.
      - Adds the original manifest path without any parameters:  
`<original scheme>://dvb.gw/<original targeted domain name>/<manifest path>/<manifest name>`

Assuming the following received request example:  
`“https://my.nip.dvb.gw/media.bbc.co.uk/simulcast/bbc-one/scotland/HDmanifest.mpd?serviceId=tag:bbc.co.uk:2021-12:bbc-one:scotland”`, The NIP Service Identifier is composed with the path part extracted from after the third ‘/’ character without the query string parameter, and add the prefixed “dvb.gw”: <https://dvb.gw/media.bbc.co.uk/simulcast/bbc-one/scotland/HDmanifest.mpd>.
    - ii. If there is no entry matching the NIP Service Identifier in the SIF table then the *Multicast Rendezvous Service* shall return 404 (Not Found).
  - b. The *Multicast Rendezvous Service* shall check whether the *NIP Gateway* is tuned to the right channel.
    - i. The *NIP Gateway* checks the Network Information File and tunes to the correct NIP Stream if necessary (i.e. not already tuned to).
  - c. The *Multicast Rendezvous Service* may locate and read the multicast gateway configuration instance document to locate the multicast configuration entry related to the service corresponding to the NIP Service Identifier.

- i. The *Multicast Rendezvous Service* may match the NIP Service Identifier (computed during step 8a) with the `PresentationManifestLocator` element attached to the multicast sessions/services.
  - ii. Alternatively, the *Multicast Rendezvous Service* may match the DVB-I Service identifier (possibly present in the received request URL (see step 5).
  - iii. If a match is found then the *Multicast Rendezvous Service* may compile a just-in-time multicast gateway configuration instance document according to clause 7.5.2.1 of ETSI TS 103 769 [8].
  - d. The *Multicast Rendezvous Service* shall redirect the request received at reference point **B** to reference point **L** of the co-located *Multicast Gateway* by means of an HTTP redirect if the corresponding service is present as part of the Service Information File per step 8a) and if the *NIP Gateway* is rightly tuned per step 8b).
    - i. The URL shall refer to the co-located *Multicast Gateway* according to clause 7.5.2.1 of ETSI TS 103 769 [8].
    - ii. The URL may include some of the optional fields specified in clause 7.5.2.1 of ETSI TS 103 769 [8].  
  
 https://dvb.gw:8088/B456789B5CC4FF/media.bbc.co.uk/simulcast/bbc-one/scotland/HDmanifest.mpd
    - iii. The URL may include the DVB-I Service identifier as a query string parameter as shown in step 5).
- 9) The *Content playback* function follows the redirect and requests the presentation manifest from the *Multicast Gateway* per clause 7.2 of ETSI TS 103 769 [8].
- 10) Void: This step is not required in the context of a DVB-NIP Broadcast System.
- 11) The *Multicast Gateway* receives the HTTP request from the *Content playback* function for the presentation manifest. The *Multicast gateway* shall check its *Content storage* cache and return the presentation manifest if it is present in the cache.

NOTE: The cache key used to index content in the *Content storage* subfunction is implementation specific. but the NIP service identifier defined below may, for example, be used for this purpose.

- a. The *Multicast Gateway* shall internally construct a URL called the NIP Service Identifier from the presentation manifest request URL according to the following.
  - Starts the URL with the received URL scheme and targeted domain name.
  - Adds the original manifest path without any parameters.

`<original scheme>://<original targeted domain name>/<manifest path>/<manifest name>`

Assuming the received request with a session identifier (i.e. token):

`"https://dvb.gw:8088/#456789B5CC4F/media.bbc.co.uk/simulcast/bbc-one/scotland/HDmanifest.mpd?serviceId=tag:bbc.co.uk:2021-12:bbc-one:scotland"`, the *NIP Service Identifier* is composed with the path part extracted from after the fourth '/' character without the query string parameter:  
`https://media.bbc.co.uk/simulcast/bbc-one/scotland/HDmanifest.mpd.`

- b) If the requested presentation manifest is not present in *Content storage* cache, the *Multicast gateway* shall retrieve it from the *Content hosting* function via unicast bidirectional access at reference point **A** (if present in the deployment) according to table 8.5.3-1.
- c) If the requested presentation manifest file is not present in the *Content storage* cache, assuming the Multicast Gateway is tuned to the correct NIP Stream (see step 8.b), the *Multicast gateway* inspects the current multicast gateway configuration instance document to check if the *NIP Gateway* is already subscribed to the corresponding multicast transport sessions.
  - i. The *Multicast Gateway* may match the NIP Service Identifier (computed during step 11a) with the URL in the `PresentationManifestLocator` element attached with the multicast session corresponding entry.

- ii. Alternatively, the *Multicast gateway* may match the DVB-I Service identifier (possibly present in the received request as a query string parameter) with the DVB-I Service identifier attached with the multicast session corresponding entry.
- iii. Alternatively, the *Multicast gateway* reads the Multicast Gateway Configuration Instance Document dedicated to the service and received as part of the requested URL (as depicted in clause 7.5.2.1 of ETSI TS 103 769 [8]).
- iv. If a matching is successful then the *Multicast gateway* shall subscribe to all relevant multicast transport session(s) according to the configuration (if not already done).

NOTE: At this stage, the *Multicast gateway* should be receiving media files (including manifest and segments). In case that the requested objects are not yet available, the *Multicast gateway* has several options depending on the availability of a unicast access as expressed in table 8.5.3-1 below.

- v. If/when no matching is possible then the service is not supposed to be delivered by multicast/broadcast. The *Multicast gateway* should rely on the unicast access, if existing, to downstream the manifest and possibly further related media elements.

NOTE: At this stage, the unicast access should exist because the *Multicast Rendezvous Service* has redirected the original request to the co-located *Multicast gateway* due to the presence of the corresponding service in the Service Information File (as explained in step 8d). The *Multicast Gateway* has several options depending on the availability of a unicast access as expressed in table 8.5.3-1.

**Table 8.5.3-1: Manifest request processing options**

Not in cache AND tuned to the right channel	NIP Gateway Unicast available	NIP Gateway NO Unicast (by design or by error)
Multicast session configured in the multicast gateway configuration instance document.	The <i>Multicast gateway</i> forwards the request over the unicast access. If <i>UnicastRepairParameters</i> element (see clause 10.2.3.12 in ETSI TS 103 769 [8]) is present the URL is computed according to clause 10.2.3.13 of ETSI TS 103 769 [8]. Otherwise, the URL is <original scheme>://<original targeted domain name>/<optional session ID>/<manifest path>/<manifest name>	The <i>Multicast gateway</i> waits an implementation-specific time period for the manifest to be received and cached), and returns error 404 ( <i>Not Found</i> ) if the waiting period expires.
Multicast session not configured in the multicast gateway configuration instance document.	The <i>Multicast gateway</i> forwards the request over reference point <b>A</b> . The request URL is <original scheme>://<original targeted domain name>/<optional session ID>/<manifest path>/<manifest name>	The <i>Multicast rendezvous service</i> returns error 404 ( <i>Not Found</i> ) according to clause 7.5.2.2 in ETSI TS 103 769 [8].

- 12) The *Multicast gateway* returns the presentation manifest back to the *Content playback* function via reference point **L**, per clause 7.2 of ETSI TS 103 769 [8].
- 13) The *Content playback* function requests a media segment (or presentation manifest) at reference point **L** per clause 7.2 of ETSI TS 103 769 [8].
- 14) The *Multicast gateway* receives the HTTP(S) request for a media segment. The *Multicast gateway* shall check its *Content storage* cache and return the requested media object if it is present in the cache.

NOTE: The cache key used to index content in the *Content storage* subfunction is implementation-specific, but the NIP Service Identifier defined in step 11a above may, for example, be used for this purpose.

- a. The *Multicast gateway* shall internally construct the NIP Service Identifier from the media segment request URL received at reference point **L** in order to locate the corresponding associated multicast session configuration elements as described in clause 10.2.2 of ETSI TS 103 769 [8].
  - i. If the URL includes a session token then the *Multicast gateway* shall associate the segment request with the NIP Service Identifier corresponding to the most recent presentation manifest request at reference point **L** including the same session token.

- ii. If the URL does not contain a session token, then the *Multicast gateway* shall assume the segment request path contains the related manifest request path. According to the step 11a:

*<original scheme>://<original targeted domain name>/<manifest path>/<segment path>*

For example, assuming the following manifest request has been processed previously:

*https://dvb.gw:8088/media.bbc.co.uk/simulcast/bbc-one/scotland/Hdmanifest.mpd*

the corresponding multicast session identifier would be the following:

*https://media.bbc.co.uk/simulcast/bbc-one/scotland/Hdmanifest.mpd*

Further related segment requests over reference point **L** shall correspond to the following:

*https://dvb.gw:8088/media.bbc.co.uk/simulcast/bbc-one/scotland/<segment path>*

For example:

*https://dvb.gw:8088/media.bbc.co.uk/simulcast/bbc-one/scotland/segment/HD/237.m4s*

- b. If the requested media segment is not in cache, the *Multicast gateway* shall retrieve it from the *Content hosting* function via unicast bidirectional access at reference point **A** (if present in the deployment) according to table 8.5.3-2.

**Table 8.5.3-2: Media segment processing options**

Not in cache	NIP Gateway Unicast available	NIP Gateway No Unicast (by design or by error)	
		NIP Client No Unicast	NIP Client Unicast available
Multicast session configured in the multicast gateway configuration instance document.	The <i>Multicast gateway</i> forwards the request over the unicast access. If <code>UnicastRepairParameters</code> element (see clause 10.2.3.12 in ETSI TS 103 769 [8]) is present the URL is computed according to clause 10.2.3.13 of ETSI TS 103 769 [8]. Otherwise, the URL is <i>&lt;original scheme&gt;://&lt;original targeted domain name&gt;/&lt;optional session ID&gt;/&lt;manifest path&gt;/&lt;manifest name&gt;</i>	The <i>Multicast gateway</i> waits an implementation-specific time period for the media segment to be received and cached, and returns error <i>404 (Not Found)</i> if the waiting period expires.	The <i>Multicast gateway</i> waits an implementation-specific time period for the media segment to be received and cached, and returns error <i>404 (Not Found)</i> if the waiting period expires. or The <i>Multicast gateway</i> redirects (code 302 or 307) the request to the <i>Content hosting</i> function (see clause 7.3 step 14 of ETSI TS 103 769 [8]). The request URL is <i>&lt;original scheme&gt;://&lt;original targeted domain name&gt;/&lt;optional session ID&gt;/&lt;manifest path if no session ID&gt;/&lt;segment path&gt;/&lt;segment name&gt;</i>
Multicast session not configured in the multicast gateway configuration instance document.	The <i>Multicast gateway</i> forwards the request over reference point <b>A</b> . The request URL is <i>&lt;original scheme&gt;://&lt;original targeted domain name&gt;/&lt;optional session ID&gt;/&lt;manifest path if no Session ID&gt;/&lt;segment path&gt;/&lt;segment name&gt;</i>	The <i>Multicast gateway</i> returns error <i>404 (Not Found)</i> .	The <i>Multicast gateway</i> returns error <i>404 (Not Found)</i> .

- i. If the requested media segment is not present in the *Content storage* cache, the *Multicast gateway* shall match the NIP session identifier (computed during step 14a) with the URL in the `PresentationManifestLocator` element of a multicast session declared in the current multicast gateway configuration.
- ii. Alternatively, the *Multicast gateway* may match the DVB-I Service identifier (if present in the received media segment request as a query string parameter) with the `@serviceIdentifier` attribute of a multicast session in the current multicast gateway configuration.
- iii. If matching is successful, the *Multicast gateway* shall subscribe to all relevant multicast transport session(s) declared by the matched multicast session (if this is not already the case).

NOTE: At this stage, the *Multicast gateway* should be receiving media objects (including the presentation manifest and media segments). However, it may take time to populate the *Asset storage* cache due to acquisition latency. The *Multicast gateway* has several options depending on the availability of unicast access to a *Content hosting* function via reference point **A**, as expressed in table 8.5.3-2 above.

- iv. If/when no matching is possible then the service is not delivered by multicast/broadcast. The *Multicast gateway* should rely on the unicast access at reference point **A** (if available in the deployment) to acquire the requested media segments.

NOTE: At this stage, the unicast access exists because the *Multicast rendezvous service* has redirected the original request to the co-located *Multicast gateway* due to the presence of the corresponding service in the Service Information File (as explained in step 8). The *Multicast gateway* has several options depending on the availability of unicast access, as expressed in table 8.5.3-2.

## 8.6 Time synchronisation

### 8.6.1 NIP Wall Clock

#### 8.6.1.1 EXT\_TIME Header Extension

The Multicast Server shall broadcast its current time using the Network Time Protocol (NTP) format as specified in RFC1305 [25]. The NTP time shall be delivered in the EXT\_TIME LCT extension header of LCT packets as defined in clause 5.2.2 of RFC5651 [26].

EXT\_TIME shall provide Sender Current Time (SCT) where both SCT-High and SCT-Low are set.

To ensure a consistent end-user experience, all head-end functions shall be synchronized via NTP or PTP servers with an accuracy to within 500ms of UTC.

#### 8.6.1.2 Carriage of Timing Information

EXT\_TIME shall be included in each LCT packet with TOI=0. These packets are used to carry the FDT (File Delivery Table).

Each FLUTE/ROUTE transport session shall convey the NTP reference time.

Receivers shall use the NTP information received from the current FLUTE/ROUTE transport session to calculate the expiration time (Expires) of the FDT.

#### 8.6.1.3 Global Time Reference

NTP time as carried by the NIP Announcement Channel FLUTE/ROUTE carousel of the bootstrap stream shall be used as the global time reference.

### 8.6.2 Local Time Offset

#### 8.6.2.1 Time Offset File

The Time Offset File (TOF) is used to convey all possible time offset values and date saving flags and related parameters.

#### 8.6.2.2 TOF Schema Declaration

```
<?xml version="1.0" encoding="UTF-8"?>
<xs:schema xmlns:xs="http://www.w3.org/2001/XMLSchema" xmlns:ns="urn:dvb:metadata:nativeip:2023" xmlns:mpeg7="urn:tva:mpeg7:2008"
targetNamespace="urn:dvb:metadata:nativeip:2023" elementFormDefault="qualified">
  <import namespace="urn:tva:mpeg7:2008" schemaLocation="tva_mpeg7.xsd"/>
  <xs:element name="TimeOffsetFile" type="ns:TimeOffsetFileType"/>
  ...
</xs:schema>
```

#### 8.6.2.3 TimeOffsetFileType

```
<xs:complexType name="TimeOffsetFileType">
```



```

<xs:sequence>
  <xs:element name="VersionUpdate" type="xs:dateTime"/>
  <xs:element name="country_code">
    <xs:simpleType>
      <xs:restriction base="xs:string">
        <xs:pattern value="[A-Z][A-Z][A-Z]"/>
      </xs:restriction>
    </xs:simpleType>
  </xs:element>
  <xs:element name="country_region_Id" minOccurs="0">
    <xs:simpleType>
      <xs:restriction base="xs:nonNegativeInteger">
        <xs:minInclusive value="0"/>
        <xs:maxInclusive value="63" />
      </xs:restriction>
    </xs:simpleType>
  </xs:element>
  <xs:element name="local_time_offset_polarity" type="xs:boolean"/>
  <xs:element name="local_time_offset_value">
    <xs:simpleType>
      <xs:restriction base="xs:nonNegativeInteger">
        <xs:minInclusive value="0"/>
        <xs:maxInclusive value="43119"/>
      </xs:restriction>
    </xs:simpleType>
  </xs:element>
  <xs:element name="time_of_change" type="xs:dateTime" minOccurs="0"/>
  <xs:element name="next_time_offset_value" type="xs:nonNegativeInteger" minOccurs="0"/>
</xs:sequence>
</xs:complexType>

```

Table 8.6.2.4-1: Time\_Offset Fields

Name	Semantic Definition	Constraints
VersionUpdate	Used to provide the version number of the TOF. It indicates the date/time of modification of the latest TOF. UTC datetime formatted in Zulu Time Format (yyyy-mm-ddThh:mm:ssZ)	Mandatory
country_code	As specified in local_time_offset_descriptor in clause 6.2.20 of ETSI EN 300 468 [14]	Mandatory
country_region_Id	As specified in local_time_offset_descriptor in clause 6.2.20 of ETSI EN 300 468 [14]	Optional
local_time_offset_polarity	As specified in local_time_offset_descriptor in clause 6.2.20 of ETSI EN 300 468 [14]	Mandatory
local_time_offset_value	Contains offset time from UTC time in seconds.	Mandatory
time_of_change	UTC time of change, if applicable, formatted in Zulu time format.	Optional
next_time_offset_value	Contains next offset time from UTC time in seconds.	Optional

#### 8.6.2.4 TOF Example

```

<?xml version="1.0" encoding="UTF-8"?>
<TimeOffsetFile xmlns="urn:dvb:metadata:nativeip:2022" xmlns:xsi="http://www.w3.org/2001/XMLSchema-instance" xsi:schemaLocation="urn:dvb:metadata:nativeip:2022 ../TimeOffsetFile.xsd">
  <VersionUpdate>2021-12-20T23:00:00Z</VersionUpdate>
  <country_code>FRA</country_code>
  <local_time_offset_polarity>0</local_time_offset_polarity>
  <local_time_offset_value>3600</local_time_offset_value>
  <time_of_change>2022-03-26T03:00:00Z</time_of_change>
  <next_time_offset_value>7200</next_time_offset_value>
</TimeOffsetFile>

```

#### 8.6.3 Time Synchronisation between DVB-I Client and NIP Gateway

The NIP Gateway shall expose the NIP Wall Clock via <http://dvb.gw/time>

The default time format shall be xs:dateTime as defined in W3C XML Schema Part 2 [i.4].

The following additional queries shall be supported:

- iso: time value formatted according to ISO time code as defined in ISO/IEC 8601
- xsdate: time value formatted according to xs:dateTime as defined in W3C XML Schema Part 2 [i.4].
- ms : time value with millisecond precision

Example:

- <http://dvb.gw/time?xsdate&ms>
- 2023-06-07T13:00:51.561Z

## 9 Application and Presentation Layer

### 9.1 Audio and Video Coding Standards

DVB-NIP only requires a single mandatory system format for the carriage of audio–visual presentations: MPEG-DASH Profile for Transport of ISO BMFF Based DVB Services over IP Based Networks ETSI TS 103 285 [11][11].

Audio Video Coding and Packaging for Native IP Adaptive Bit Rate applications shall be according to ETSI TS 103 285 [11][11].

### 9.2 Captions and Subtitles

NIP Clients shall be able to correctly render TTML based subtitles according to clause 7 of DVB-DASH (ETSI TS 103 285 [11][11]).

### 9.3 Time Shifting

Timeshifting for connected receivers shall be according to ETSI TS 103 285 [11][11].

Timeshifting for unconnected receivers is outside the scope of the present document.

### 9.4 Service Usage Reporting

Service Usage Reporting for connected receivers shall be according to clauses 5.3.6.1, 5.3.8.4, 10.2.2.3 and 11 of ETSI TS 103 769 [13]. Service Usage Reporting for unconnected receivers is outside the scope of the present document.

## 10 Content Protection

### 10.1 Introduction

Content protection signalling shall be according to clause 8.4 of ETSI TS 103 285 [11]. DVB NIP does not specify a full end-to-end content protection system (DRM).

DVB NIP re-uses the content protection principles set out by DVB-DASH [11]. Such principles are the usage of specific parameters that are defined within the MPEG DASH ISO/IEC 23009-1 [i.1] MPD and within the ISO Common Encryption “CENC” (ISO/IEC 23001-7 [i.2]). This enables multiple DRMs to protect the content, sharing information (such as KeyIDs and ivs), and then using an opaque container for each DRM to carry DRM specific data (such as licence or licence acquisition information).

The protection of content is optional in DVB NIP but if used, it shall be in accordance with clause 8 of DVB-DASH [11].

### 10.2 Connected Receivers

In the case of DVB-I Clients connected to a NIP Gateway and/or to an IP network via broadband, the DVB-I Client secure player shall comply to content protection mechanisms as specified in DVB-DASH ETSI TS 103 285 [11].

## 10.3 Unconnected Receivers

The signalling and the carriage of secure key assets and processes in a non-IP connected environment will be specified in a subsequent version of the present document.

---

# 11 Deployment Specific Protocols

## 11.1 NIP Gateway Announcement and Discovery Protocol

### 11.1.1 Introduction

Consumer NIP Gateways according to DM3 shall support DNS-SD/mDNS as network device discovery protocol.

This guarantees that network clients can easily discover the presence of a NIP Gateway on the local network and discover the services provided by the NIP Gateway.

NIP clients shall support the DNS-SD/mDNS Network Device Announcement and Discovery Protocol as specified under clause 11.1.2.

### 11.1.2 DNS-SD/mDNS

#### 11.1.2.1 General

The method described in the present clause is intended to be applicable in DVB-NIP and DVB-HB [13] contexts. In particular, the term DVB Gateway indicates a device which may provide functions of a DVB-NIP Local Server as defined in the present document, a DVB-HB Gateway as defined in DVB-HB [13], or both.

A DVB Gateway shall announce its presence on the LAN and answer DVB client host query requests using the DNS-SD mechanism defined in IETF RFC 6763 [18] in conjunction with mDNS as defined in IETF RFC 6762 [17] and according to the following:

- A registered DVB Gateway service;
- At least three Domain Name System (DNS) records: a Pointer (PTR) record, a Service (SRV) record and a Text (TXT) record.

A client implementing this method shall support the DVB Gateway discovery according to IETF RFC 6763 [18] and IETF RFC 6762 [17], taking into account the information exposed in the DNS records as described in clause 11.1.2.2, clause 11.1.2.3 and clause 11.1.2.4.

#### 11.1.2.2 Pointer Record (PTR)

The PTR record is used to point clients looking for a DNS-SD service to the devices providing that service. The PTR record format is as follows:

```
<Service Type>.<Domain> <TTL> PTR <Instance Name>.<Service Type>.<Domain>
```

where:

<Service Type> is the combination of a standard IP protocol name and a transport protocol name both prefixed with the underscore ‘\_’ character. The DVB Gateway shall use the following Service Type: `_dvbservdsc._tcp`. Additionally, the DVB Gateway should use the Service Type `_http._tcp` if the exposed service is also an HTTP server.

<Domain> shall be set to `local`.

<TTL> is the value in seconds of Time To Live in cache.

<Instance Name> is the instance name of the service. It may be up to 63 bytes.

Information on how to build Instance Names is provided in IETF RFC 6763 [18]. A recommendation is to provide short, descriptive and human-readable names. Unicode characters including spaces are allowed by IETF RFC 6763 [18].

Below are three examples of a DVB Gateway PTR record:

```
_dvbservdsc._tcp.local. 86400 PTR DVB Gateway Manufacturer A Model B._dvbservdsc._tcp.local.
_dvbservdsc._tcp.local. 86400 PTR Live TV Airport Lounge 2._dvbservdsc._tcp.local.
_dvbservdsc._tcp.local. 86400 PTR dvb:gw:35:7B:12:48:DE:01._dvbservdsc._tcp.local.
```

### 11.1.2.3 Service Record (SRV)

The SRV record has the following structure, as defined in IETF RFC 6763 [18] and IETF RFC 2782 [24]:

```
<Instance Name>.<Service Type>.<Domain> <TTL> IN SRV <Priority> <Weight> <Transport Port> <IP addresses>
```

It associates the name of a service (structured as <Instance Name>.<Service Type>.<Domain>) with the IP address and port number of a server (host device) that offers that service, allowing a client to discover the local DVB Gateway service.

Below is an example of a DVB Gateway SRV record:

```
DVB Gateway Model A._dvbservdsc._tcp.local. 86400 IN SRV 0 0 80 192.168.1.101.
```

### 11.1.2.4 Text Record (TXT)

The TXT record is intended to convey a small amount of useful additional information about a service. It is a concatenated list of "key=value" pairs separated by semicolons, with the following structure:

```
<Instance Name>.<Service Type>.<Domain> <TTL> TXT "<key_1>=<value_1>[;<key_n>=<value_n>]"
```

Available keys for the TXT record are given in table 1.

Table 1: TXT record keys

Key	Semantic Definition	Constraints
txtvers	Decimal version number of the TXT record, as defined in IETF RFC 6763 [18].	Optional
dvbi_sep	URL of the Service List Entry Points exposed by the DVB Gateway. It can be local or remote.	Either dvbi_sep or dvbi_sl is mandatory
dvbi_sl	URL of the DVB-I Service List exposed by the DVB Gateway. It can be local or remote.	Either dvbi_sep or dvbi_sl is mandatory
priv_loc	URL of private signalling data for DVB Gateways not implementing DVB-I functionality.	Optional
cprot_ep	URL pointing to content protection server.	Optional
manuf	Manufacturer's name.	Optional
model	Model name of the device.	Optional
sn	Serial number of the device.	Optional
tuners	List of pairs of supported modulation types and respective numbers of tuners. Multiple pairs are separated by " ". Modulation type and number of tuners of that kind are separated by "/". Possible values of modulation type are: "DVB-T", "DVB-T2"; ", "DVB-S", "DVB-S2", "DVB-S2X" "DVB-C". Example: tuners=DVB-T2/4 DVB-S2/2	Optional
orb_pos_A	First received orbital position, expressed in positive or negative degrees representing East and West directions respectively. Relevant only if the DVB Gateway also includes satellite tuners.	Optional
orb_pos_B	Second received orbital position, expressed in positive or negative degrees representing East and West directions respectively. Relevant only if the DVB Gateway also includes satellite tuners.	Optional
orb_pos_C	Third received orbital position, expressed in positive or negative degrees representing East and West directions respectively. Relevant only if the DVB Gateway also includes satellite tuners.	Optional
orb_pos_D	Fourth received orbital position, expressed in positive or negative degrees representing East and West directions respectively. Relevant only if the DVB Gateway also includes satellite tuners.	Optional

Optional parameters are intended for filtering at client-side in case several DVB Gateway are available on the LAN. However, according IETF RFC 6763 [18], the TXT record is intended to be small, i.e., it should be kept below 1300 bytes to fit into a single Ethernet packet.

Below are two examples of a DVB Gateway TXT record.

DVB Gateway Model A.\_dvbservdsc.\_tcp.local. 86400 IN TXT "txtvers=1;dvbi\_sep=http://192.168.1.101:80/ServiceListEntryPoints.xml"

Live TV Airport Lounge 2.\_dvbservdsc.\_tcp.local. 86400 IN TXT "dvbi\_sl=https://www.example.com/dvb-i/sl/Service-List\_France\_1.xml;tuners=DVB-S2/16;orb\_pos\_A=-5;orb\_pos\_B=19.2"

## 11.2 Professional Edge Cache Receiver Configuration

### 11.2.1 Control API

A REST Control API for professional Edge Cache Receivers will be provided in a subsequent version of this document.

---

## Annex A (normative): Transport Stream based carriage

### A.1 Introduction

Receivers deployed with hardware that cannot be upgraded to the use of GSE-Lite according to ETSI TS 102 606-1 [4] may nevertheless support DVB Native IP transmissions with adapted software. In such deployments, the data link layer protocol to be used shall be Multi-Protocol Encapsulation (MPE) as specified in ETSI EN 301 192 7 [7] and based on data section transport using Transport Stream Packets according to ISO/IEC 13818-1 [15].

---

### A.2 Multi-Protocol Encapsulation (MPE)

Using Multi-Protocol Encapsulation, IP datagrams are encapsulated in datagram\_sections that are mapped into Transport Stream packets as defined in MPEG-2 systems ISO/IEC 13818-1 [15]. MPE datagram sections are specified in clause 7 of ETSI EN 301 192 [7]. The LLC-SNAP\_flag in Table 3 of clause 7 of ETSI EN 301 192 [7] shall be set to “0”.

In DVB-NIP, MPE datagram sections are carried as part of a DVB defined Service within a Transport Stream. MPE sections are identified through their table\_id in the section header (set to “0x3E”) and their stream\_type 0x0D in the PMT. A given service shall carry not more than one MPE stream. However within a transport stream multiple services, each carrying an MPE stream may coexist.

Services carrying MPE shall be identified in their TS as specified in ETSI EN 301 192 [7] and ETSI EN 300 468 [14]. At NIP level MPE services shall be described in the SIF table via their service\_id, transport\_stream\_id and network\_id.

All NIP Stream related features specified in the current document equally apply between GSE-Lite and MPE Streams with a single exception: IP ROHC according to clause 7.4 shall not be applied when carrying IP datagrams within MPE Streams.

---

### A.3 MPE Signalling

#### A.3.1 In the Network Information File

Signalling mechanisms described under clause 8 of the present document shall also apply for Streams carried using MPE. In particular the use of MPE for the transport of all or some of the Streams part of DVB-NIP platforms shall be indicated in the Network Information File (NIF) <LinkLayerFormat> element carried as part of the NIP Announcement Channel.

#### A 3.2 Linkage descriptor in a Transport Stream NIT or BAT

NIP receivers supporting MPE may locate the presence of a NIP platform by following the linkage descriptor specified under this clause. Such linkage descriptor may be provided in the NIT of a TS based network in order to facilitate access to a NIP platform, where the bootstrap streams of a certain provider platform cannot be located through other means. This descriptor shall be carried in the first loop of the NIT or BAT. Several instances of this descriptor may be present on a given network linking to different Operators. If the same descriptor for the same provider\_name appears in both the NIT and BAT, the BAT takes precedence.

An MPE based NIP receiver shall follow the provider name linkage for which it was designed or present to the user a choice of available provider names. At the end of the process a NIP compliant MPE based receiver shall tune to the Transport Stream and service\_id indicated in the corresponding linkage\_descriptor and that carries the Bootstrap Stream information as part of its Announcement Channel (clause 8.1.5).

Table A3.2-1 defines a User Defined Linkage Descriptor pointing from a NIT or BAT to the Bootstrap Stream of a NIP platform provider\_name.

**Table A3.2-1: Syntax for the linkage descriptor of type 0x21**

Syntax	No. of bits	Identifier
linkage_descriptor() {		
descriptor_tag	8	uimsbf
descriptor_length	8	uimsbf
transport_stream_id	16	uimsbf
original_network_id	16	uimsbf
service_id	16	uimsbf
linkage_type	8	uimsbf
if (linkage_type == 0x21) {		
provider_name_length	8	uimsbf
for (i=0; i<provider_name_length; i++) {		
text_char	8	uimsbf
}		
BootstrapType	1	bslbf
reserved_zero_future_use	7	uimsbf
for (j=0; j<N; j++) {		
private_data_byte	8	uimsbf
}		
}		
}		

#### Semantics of the private data bytes for linkage type 0x21:

**transport\_stream\_id:** This is a 16-bit field which identifies the TS containing the NIP Bootstrap Stream.

**original\_network\_id:** This 16-bit field gives the label identifying the network\_id of the originating delivery system of the transport stream carrying the NIP Bootstrap Stream.

**service\_id:** This is a 16-bit field which identifies the service containing the NIP Bootstrap Stream.

**linkage\_type:** This is an 8-bit field specifying the type of linkage, and shall be set to 0x21.

**provider\_name\_length:** This 8-bit field specifies the total length in bytes of the following provider\_name.

**text\_char:** This is an 8-bit field. A string "text\_char" fields specifies the platform name as described above. Text information is coded using the character sets and methods described in annex A of ETSI EN 300 468 [14].

**BootstrapType:** This 1-bit field indicates the scope of the NIF carried by the declared Bootstrap Stream. A value "0" indicates that the NIF describes the complete physical broadcast network from a "Technical Operator". A value "1" indicates that the NIF describes streams from a "Commercial Operator" carrying content for a specific Bouquet, as defined in ETSI EN 300 468 [14].

**private\_data\_byte:** This is an 8-bit field, the value of which is privately defined.

---

## A.4 Simultaneous GSE-Lite and MPE operation

Operation with some streams being carried via MPE using DVB-S2 according to clause 7.2.3 and others via GSE-Lite using DVB-S2X according to clause 7.2.2 may be supported as part of some NIP deployments.

# Annex B (informative): Sequence Diagram

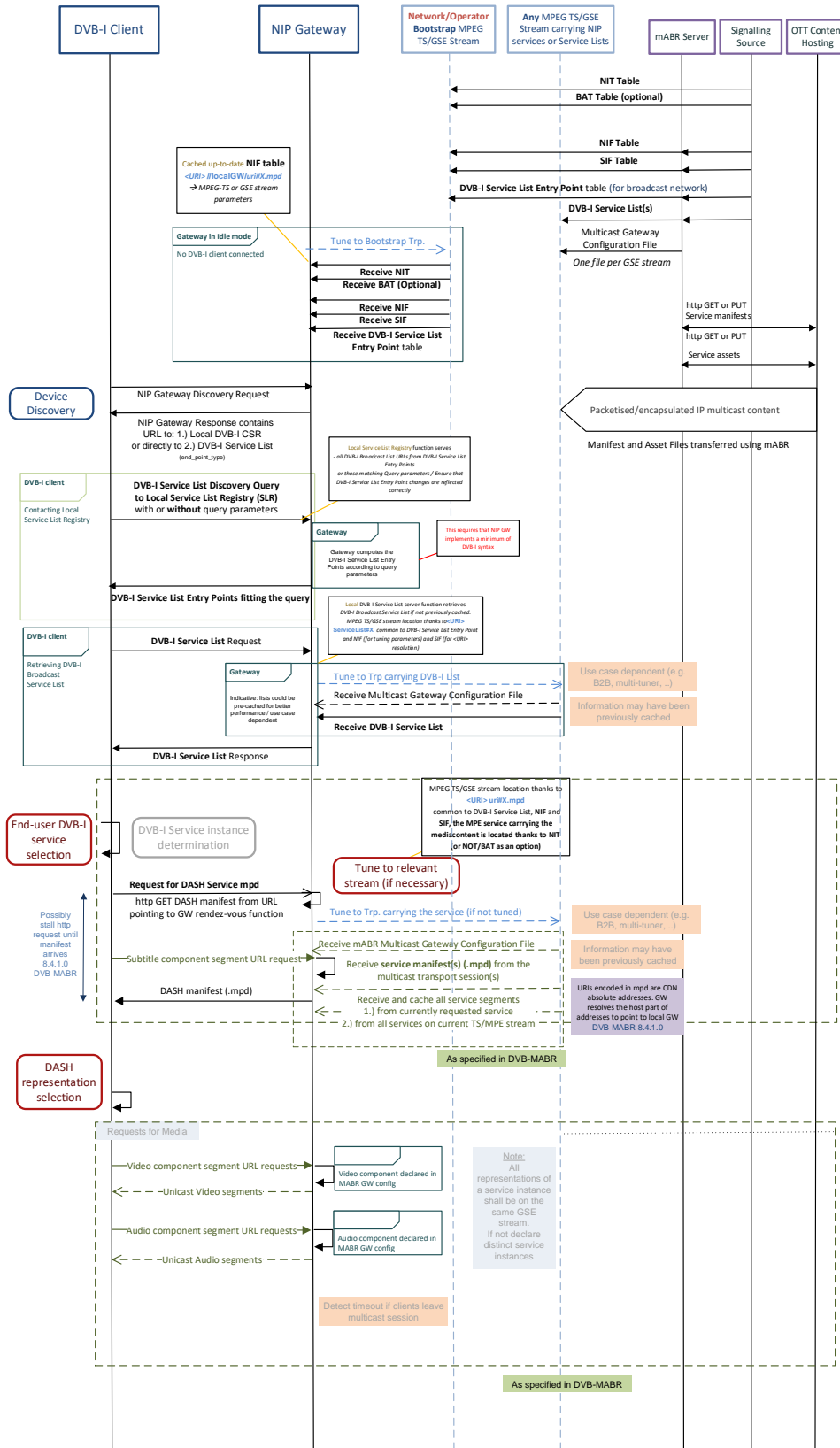



---

## Annex C (informative): System Operation and Implementation Guidelines

### C.1 Introduction

This chapter provides informative recommendations to Operators and Manufacturers in order to help optimize the implementation of end-to-end NIP deployments. In particular this chapter provides best practices for broadcasters and for manufacturers developing NIP Gateways designed for horizontal or vertical markets defined as:

- Horizontal Markets describe those NIP deployments which are not linked to any specific Commercial Operator. Such deployments rely on standardised receivers which are distributed through open retail channels and are capable of receiving any compliant broadcast signal.
- Vertical Markets describe deployments in relation to a particular Commercial Operator.

---

### C.2 Horizontal versus vertical market deployments

A NIP Gateway designed for Horizontal Markets should provide access to any broadcast network, independently of any proprietary features related to any specific Commercial Operator.

Such NIP Gateways will target, as a preference, Bootstrap Streams tagged with BootstrapType value = “Physical Network”.

This should not preclude any DVB-I Client connected to such NIP Gateway to access a Commercial Operator or an Aggregator Bootstrap Stream, present on the Broadcast Network, as described hereafter under clause C.4.2.

A NIP Gateway designed for a particular Vertical Market may integrate proprietary features and specific Bootstrap Stream(s) presets.

---

### C.3 Recommendations to content originators

As specified in clause 8.3.2, Broadcast Service List Entry Points should reflect Broadcast Service Lists as proposed on the current Broadcast Network.

DVB-I Service Lists carried over the Broadcast Network should be optimized for that network.

As specified in clause 8.3.1, all representations of a given Service and declared in the service MPD are present on the current Broadcast Stream or available via broadband. Therefore, the service manifest should be designed on purpose for the actual broadcast network.

---

### C.4 Recommendations to NIP Gateway manufacturers

#### C.4.1 Discovery of Bootstrap Streams

NIP Gateways should integrate a list of pre-stored settings of Bootstrap Streams – In the case of Horizontal Market Gateways, those are the Bootstrap Streams provided by Technical Network Operators and in the case of Vertical Markets those are the Bootstrap Stream(s) provided by the Commercial Operator or Aggregator.

In the event of obsolete pre-stored settings – see clause 8.1.4.1, there should be a fallback method based on physical scanning of the broadcast network. For each frequency locked, the receiver should attempt to tune to and parse the Announcement Channel for NIF, SIF and DVB-I Service List Entry Points.

- Horizontal Market receivers should target the NIF, SIF and co-located DVB-I Service List Entry Points searching for Bootstrap Streams tagged with BootstrapType value = “Physical Network”.
- Gateways designed for Vertical Market Operators identified by their ProviderName should target the NIF, SIF and co-located DVB-I Service List Entry Points searching for Bootstrap Streams tagged with BootstrapType value = “Commercial Operator”.

## C.4.2 Switching between Provider Bootstrap Streams

A NIP Gateway designed for horizontal markets and installed thanks to the Physical Network Bootstrap Stream, should still be capable of providing access to any Bootstrap Stream of any Commercial Operator or Aggregator, present on the current Broadcast Network, if requested by a DVB-I Client.

It is indeed possible, as specified in ETSI TS 103 770 [9] that a DVB-I client during the discovery phase queries a DVB-I service list for a particular ProviderName.

The NIP Gateway should then parse the NIF, searching for a Bootstrap Stream declared for that particular ProviderName and subsequently tune to this Bootstrap Stream. The NIP Gateway should download NIF, SIF and DVB-I Service List Entry Points for that Provider. The rest of the process remains identical as nominal one.

The flexibility described here requires that the Commercial Operator or Aggregator provides up-to-date Bootstrap Stream parameters to the Technical Network Operator.

## C.4.3 Caching of Signalling Information

DVB-NIP signalling relies on the download and parsing of multiple files to discover the broadcast network topology. Some of these files are only broadcast on the dedicated bootstrap streams. In order to optimize the end-user experience it is recommended that NIP Gateways cache the following files and perform regular update checks:

- NIF.
- SIF.
- Service List Entry Points.

And for each NIP Stream, the corresponding Multicast Gateway Configuration Instance Document.

In order to propose a maximum amount of content to End-Users, a NIP Gateway should concatenate cached DVB-I Service List Entry Points.

## C.5 Support of MPEG/PES based services

### C.5.1 DVB-I Service List signalling

The broadcast DVB-I Service Lists may also include signalling of services provided by a DVB TS-broadcast head-end, by indicating the relevant DVBSDeliveryParameters or DVBTDeliveryParameters elements according to ETSI TS 103 770 [9].

### C.5.2 Integrated Native IP TVs (DM2)

Support of MPEG/PES based services is feasible for any Integrated Native IP TV featuring an MPEG demultiplexer and Audio-Video decoder.

### C.5.3 Home Gateway + IP Clients (DM3)

Support of MPEG/PES based services is feasible for NIP Gateways implementing DVB-HB Profile B according to DVB document A179 [13].

## Annex D (informative): Amendments to existing DVB specifications

The following specifications will need amendments for the implementation of DVB-NIP:

Specification, Reference and Version	Clause	Amendment
DVB-S2X ETSI EN 302 307-1 [1] V1.3.1 (2021-07)	5.1.7	UPs can be sliced except if ISSY is active.
DVB-GSE Part 1 ETSI TS 102 606-1 [4] V1.2.1 (2014-07)	Annex D.2.2	Remove following paragraph: " For maximum efficiency and to provide a simple receiver mode where PDU fragmentation is not necessary, it is required that when HEM (High Efficiency Mode) is used on the physical layer, the maximum number of concurrent GSE fragments is 1, which means that PDU fragmentation is not performed on the GSE layer. In this case it is expected that physical layer slicing will be performed as necessary.
DVB-GSE Part 2 ETSI TS 102 606-2 [5] V1.2.1 (2016-12)	5.1 5.2.1 5.2.2.10 5.2.2.15 5.2.2.16 5.2.2.17 Annex A.3 Annex A.4.3 (Figure A.8)	Record Structures Descriptor Identification and Location Modified Descriptor: ROHC-U descriptor Additional Descriptors: IP multicast list descriptor IPv6 multicast list descriptor ROHC-U multicast descriptor Underlying data model Example of multicast transport
DVB-GSE Part 3 ETSI TS 102 606-3 [6] V1.1.1 (2014-07)	4.1.2 4.1.3 4.2 5	ROHC parameters ROHC Rules of Operation Adaptation Module Transport in GSE
DVB-SI ETSI EN 300 468 [14] V1.16.1 (2019-08)	Figure 60 clause 6.2.19	Add linkage_type 0x21 pointing towards a DVB-NIP bootstrap stream.

## Annex E (informative): Change History

Date	Version	Information about changes
February 2022	A180	First BlueBook publication
		<ul style="list-style-type: none"> <li>- §8.1.4.2/§8.4.2.2.5/§8.4.2.2.6.1/§8.4.2.2.6.2/§8.4.2.2.3.1: fixing NIPLinkID definition</li> <li>- §8.2.4: CRC8 -&gt; CRC32</li> <li>- §8.4.2.6 (3 times): Frequency expression (delivery parameters) → in 10kHz steps (positiveinteger)</li> <li>- §8.4.2.2.6 (2 times): Symbol rate expression in kS/s (positive integer)</li> <li>- §8.4.2.3: interactiveApplication (misalignment fixed)</li> <li>- Note that .xsd and examples have been updated accordingly.</li> </ul> <hr/> <ul style="list-style-type: none"> <li>- §7.3.2: added GSE label usage recommendation</li> </ul> <hr/> <ul style="list-style-type: none"> <li>- §8.4.2.2.2 / §8.4.3.2.2 / §8.6.2.2 / §8.6.2.3: fixing the limitation of ZuluTime datetime format based on DVB-I restricted definition by applying W3C/XML schema/datetime type.</li> <li>- §8.6.2.1: removal of DVB-I declaration from NTI</li> </ul> <hr/> <ul style="list-style-type: none"> <li>- §8.1.4.2: editorial fix of missing word "single" defining NIPLinkId value in the case of single link in a GSE stream.</li> <li>- §8.4.2.2.2.2 / §8.4.3.2.2.2: editorial precision about VersionUpdate field meaning.</li> <li>- Renumbering §8.6.2.3 → §8.6.2.4 and §8.6.2.4 → §8.6.2.5</li> <li>- §8.6.2.3: new simple type NTI_DateTime with a precision of 1ms.</li> <li>- §8.6.2.2 §8.6.2.5: UTC_Time referencing new simple type NTI_DataTime.</li> <li>- §8.6.2.5: editorial fixing (upper cases alignment with schema).</li> </ul>
July 2023	A180r1	<ul style="list-style-type: none"> <li>- §2.1: new references according to Device Discovery protocol and NIP Wall Clock</li> <li>- §2.1 new references according to W3C Language1.1</li> <li>- §2.2: NIP Wall Clock definition</li> <li>- §Figure 5.2.1-1: DVB-NIP protocol stack</li> <li>- §Figure 5.3.1: architecture of the DVB-NIP system update</li> <li>- §8.1.6: schemes modification to reflect the use of DVB-MABR carousel to convey NIP Announcement Channel</li> <li>- §8.2: complete rework to use DVB-MABR carousel to convey NIP Announcement Channel</li> <li>- §8.2.2: NIP Announcement Channel filtering mechanism at NIP stream change</li> <li>- §8.2.5.2: NIP Announcement Channel file update detection</li> <li>- §8.4.2.2.1: NIF schema fix</li> <li>- §8.4.2.6.6.1/§8.4.2.6.6.2: input_stream_identifier as unsignedByte.</li> <li>- §8.4.2.2.7: NIF example fixes <ul style="list-style-type: none"> <li>o Fix &lt;PLS&gt; element replaced with &lt;scrambling_sequence_index&gt;</li> <li>o Editorial fix: &lt;InputStreamIdentifier&gt; replaced with &lt;input_stream_identifier&gt;</li> </ul> </li> <li>- §8.4.3.2.1: SIF schema fix</li> <li>- §8.4.3.2.2: removal of variable "NetworkName"</li> <li>- §8.4.3.2.5: SIF example fixes</li> <li>- §8.6.: complete rework of Time management mechanism <ul style="list-style-type: none"> <li>o NIP Wall Clock definition</li> <li>o Removal of NTI document</li> <li>o Adding Time Offset File document <ul style="list-style-type: none"> <li>▪ &lt;VersionUpdate&gt;</li> </ul> </li> <li>o NIP Gateway NIP Clock Wall time exposure to Client</li> </ul> </li> <li>- §11.1. removal of UPnP Device Discovery protocol</li> <li>- §11.1.: full revision of DNS/SD-mDNS Device Discovery specification</li> <li>- Annex B: sequence diagram reflecting the use of DVB-MABR carousel to convey NIP Announcement Channel</li> </ul>