



**Digital Video Broadcasting (DVB);
Frame Compatible Plano-Stereoscopic 3DTV
(DVB-3DTV)**

DVB Document A154

February 2011



Contents

Intellectual Property Rights	4
Foreword.....	4
Introduction	5
1 Scope	6
2 References	6
2.1 Normative references	6
2.2 Informative references	6
3 Definitions, symbols and abbreviations	7
3.1 Definitions	7
3.2 Abbreviations.....	8
4 Frame compatible plano-stereoscopic 3DTV services in DVB delivery systems.....	8
4.1 3DTV services	9
4.2 3DTV IRDs.....	10
5 Video and audio codecs usage	12
5.1 Video	12
5.2 Audio	14
6 Signalling	14
6.1 Programme Specific Information.....	15
6.2 Service Information	15
6.2.1 Service type.....	15
6.2.2 Component type	16
6.2.3 Content descriptor	16
6.2.4 Linkage descriptor.....	16
6.2.5 Video depth range descriptor	16
6.3 Service Signalling scenarios	17
6.4 Video stream signalling	18
6.5 Video format transitions	19
7 Graphics and captions display (informative).....	21
7.1 On-screen graphics	21
7.2 Subtitles	22
Annex A: Frame compatible plano-stereoscopic 3DTV video formats (informative).....	23
A.1 Side-by-Side frame compatible video format	23
A.2 Top-and-Bottom frame compatible video format	24
Annex B: HDTV service compatibility (informative)	26
History	28

Intellectual Property Rights

IPRs essential or potentially essential to the present document may have been declared to ETSI. The information pertaining to these essential IPRs, if any, is publicly available for ETSI members and non-members, and can be found in ETSI SR 000 314: "*Intellectual Property Rights (IPRs); Essential, or potentially Essential, IPRs notified to ETSI in respect of ETSI standards*", which is available from the ETSI Secretariat. Latest updates are available on the ETSI Web server (<http://webapp.etsi.org/IPR/home.asp>).

Pursuant to the ETSI IPR Policy, no investigation, including IPR searches, has been carried out by ETSI. No guarantee can be given as to the existence of other IPRs not referenced in ETSI SR 000 314 (or the updates on the ETSI Web server) which are, or may be, or may become, essential to the present document.

Foreword

This Technical Specification (TS) has been produced by Joint Technical Committee (JTC) Broadcast of the European Broadcasting Union (EBU), Comité Européen de Normalisation ELECTrotechnique (CENELEC) and the European Telecommunications Standards Institute (ETSI).

NOTE: The EBU/ETSI JTC Broadcast was established in 1990 to co-ordinate the drafting of standards in the specific field of broadcasting and related fields. Since 1995 the JTC Broadcast became a tripartite body by including in the Memorandum of Understanding also CENELEC, which is responsible for the standardization of radio and television receivers. The EBU is a professional association of broadcasting organizations whose work includes the co-ordination of its members' activities in the technical, legal, programme-making and programme-exchange domains. The EBU has active members in about 60 countries in the European broadcasting area; its headquarters is in Geneva.

European Broadcasting Union
CH-1218 GRAND SACONNEX (Geneva)
Switzerland
Tel: +41 22 717 21 11
Fax: +41 22 717 24 81

The Digital Video Broadcasting Project (DVB) is an industry-led consortium of broadcasters, manufacturers, network operators, software developers, regulatory bodies, content owners and others committed to designing global standards for the delivery of digital television and data services. DVB fosters market driven solutions that meet the needs and economic circumstances of broadcast industry stakeholders and consumers. DVB standards cover all aspects of digital television from transmission through interfacing, conditional access and interactivity for digital video, audio and data. The consortium came together in 1993 to provide global standardisation, interoperability and future proof specifications.

Introduction

Plano-stereoscopic imaging systems deliver two images (left and right) that are arranged to be seen simultaneously, or near simultaneously, by the left and right eyes. Viewers perceive increased depth in the picture, which becomes more like the natural binocular viewing experience. Since 2010 many 3DTV capable consumer products have been launched in the market.

The present document specifies the delivery system for frame compatible plano-stereoscopic 3DTV services, enabling service providers to utilise their existing HDTV infrastructures to deliver 3DTV services that are compatible with 3DTV capable displays already in the market. This system covers both use cases of a STB delivering 3DTV services to a 3DTV capable display device via an HDMI connection, and a 3DTV capable display device receiving 3DTV services directly via a built-in tuner and decoder.

1 Scope

The present document specifies the methods to encode and deliver DVB frame compatible plano-stereoscopic 3DTV services over conventional HDTV broadcast infrastructures, and their decoding by a digital receiver. This includes the selection of frame compatible plano-stereoscopic 3DTV formats, the definition of frame compatible plano-stereoscopic 3DTV service signalling information, and the handling of graphics and captions overlays in the receiver during the reception of a frame compatible plano-stereoscopic 3DTV service. Some elements are contained in amendments and extensions to the appropriate existing DVB specifications.

The production and contribution of frame compatible plano-stereoscopic 3DTV content prior to delivery, as well as the method of rendering the frame compatible plano-stereoscopic 3DTV content to the viewer at the 3DTV capable display device after its reception and decoding, are outside the scope of the present document.

2 References

References are either specific (identified by date of publication and/or edition number or version number) or non-specific. For specific references, only the cited version applies. For non-specific references, the latest version of the referenced document (including any amendments) applies.

Referenced documents which are not found to be publicly available in the expected location might be found at <http://docbox.etsi.org/Reference>.

NOTE: While any hyperlinks included in this clause were valid at the time of publication ETSI cannot guarantee their long term validity.

2.1 Normative references

The following referenced documents are necessary for the application of the present document.

- [H222_MP2TS] ITU-T Recommendation H.222.0 (2006)/ ISO/IEC 13818-1:2007: "Information Technology - Generic Coding of moving pictures and associated audio information: Systems".
- [H222_TSVC] ITU-T Recommendation H.222.0 (2006)/ ISO/IEC 13818-1:2007, Amendment 3: "Transport of Scalable Video over ITU-T Rec. H.222.0 / ISO/IEC 13818-1".
- [H222_TMVC] ITU-T Recommendation H.222.0 (2006)/ ISO/IEC 13818-1:2007, Amendment 6: "Extension to AVC video descriptor and signaling of operating points for MVC".
- [H264_AVC] ITU-T Recommendation H.264 / ISO/IEC 14496-10:2010: "Information technology - Coding of audio-visual objects - Part 10: Advanced Video Coding".
- [TS101154] ETSI TS 101 154 V1.10.1 (2011-XX), "Digital Video Broadcasting (DVB); Specification for the use of Video and Audio Coding in Broadcasting Applications based on the MPEG-2 Transport Stream".
- [EN300468] ETSI EN 300 468 V1.12.1 (2011-XX), "Digital Video Broadcasting (DVB); Specification for Service Information (SI) in DVB systems".
- [EN300743] ETSI EN 300 743 V1.4.1 (2011-XX), "Digital Video Broadcasting (DVB) – Subtitling systems".

2.2 Informative references

The following referenced documents are not necessary for the application of the present document but they assist the user with regard to a particular subject area.

- [HDMI14a] HDMI LLC, High-Definition Multimedia Interface Specification Version 1.4a. March 4, 2010. <http://www.hdmi.org/manufacturer/specification.aspx>

- [BT2160] ITU-R BT.2160 (11/2009), “Features of three-dimensional television video systems for broadcasting”.
- [TS101211] ETSI TS 101 211 V1.x.1 (2011-XX), “Digital Video Broadcasting (DVB); Guidelines on implementation and usage of Service Information (SI)”.

3 Definitions, symbols and abbreviations

3.1 Definitions

For the purposes of the present document, the following terms and definitions apply:

3DTV: DVB frame compatible plano-stereoscopic three-dimensional television.

3DTV compliant IRD: An IRD that is both 3DTV cognisant and that is able to render frame compatible plano-stereoscopic 3DTV video content correctly, being either a 25 Hz plano-stereoscopic 3DTV IRD or a 30 Hz plano-stereoscopic 3DTV IRD as defined in [TS101154].

3DTV cognisant IRD: An IRD that is able to identify frame compatible plano-stereoscopic 3DTV services via the corresponding Service Information (DVB-SI), and the frame compatible plano-stereoscopic 3DTV video format, but that is not necessarily able to render frame compatible plano-stereoscopic 3DTV video content correctly.

3DTV incognisant IRD: An IRD that is not able to identify frame compatible plano-stereoscopic 3DTV services via the corresponding Service Information (DVB-SI), nor the frame compatible plano-stereoscopic 3DTV video format.

Captions: Text and visual elements intended to be overlaid on the picture as an optional feature, e.g., subtitles for foreign language source material, or for viewers with impaired hearing.

Disparity: Difference between the horizontal positions of a pixel representing the same point in space in the right and left views. Positive disparity (horizontal right coordinate greater than horizontal left coordinate) implies a position behind the plane of display, and negative disparity implies a position in front of the display.

Frame Compatible: The arrangement of the Left and Right images in a spatial multiplex which results in an image which can be treated like a normal HDTV image by the receiver demodulator and compression decoder.

HD ready, HD 1080: Labels authorised by Digital Europe to classify HDTV TV displays.

HDMI: The High-Definition Multimedia Interface consortium, which has specified the digital connection between HD video source devices and displays.

Natural binocular viewing: The process of viewing with two eyes, as is done by most people.

Pixel arrangements: The arrangement of horizontal and vertical image samples. This has an impact on vertical, horizontal, or diagonal resolution.

Plano-stereoscopic: A three-dimensional picture that uses two single pictures, Left and Right, displayed on a single plane surface (the TV screen in the case of 3DTV).

Polarisation planes: An optical filter system used to direct the left and right eye images to the appropriate eye.

Side-by-Side (SbS): The arrangement of the Frame Compatible spatial multiplex such that the horizontally anamorphic Left eye picture is placed in a spatial multiplex to occupy the first half of each line, and the Right eye picture is placed in the spatial multiplex to occupy the second half of each line.

Service Compatible: The arrangement of the Left and Right images such that an existing HDTV receiver is able to extract a 2D version of the video content from a frame compatible plano-stereoscopic 3DTV service.

Service Guide: Usually information on programme choice displayed on the screen, and often derived from now and next information broadcast in the multiplex.

Simulcast: Parallel broadcasting of the same programme, often in different forms or formats.

Top-and-Bottom (TaB): The arrangement of the Frame Compatible spatial multiplex such that the vertically anamorphic Left eye picture is placed in the spatial multiplex to occupy the first (top) half of a single HD video frame, and the Right eye picture is placed in the spatial multiplex to occupy the second (bottom) half of a single HD video frame.

Titles: Usually all forms of text and graphics that appear on top of a TV scene or another background, intended to be visible for all TV viewers.

3.2 Abbreviations

For the purposes of the present document, the following abbreviations apply:

EPG	Electronic Programme Guide
ES	Elementary Stream
NOTE:	As defined in [H222_MP2TS].
FC	Frame Compatible
HD	High Definition
HDMI	High-Definition Multimedia Interface
IDR	Instantaneous Decoding Refresh
NOTE:	As defined in [H264_AVC].
IRD	Integrated Receiver Decoder
PMT	Programme Map Table
NOTE:	As defined in [H222_MP2TS].
PSI	Programme Specific Information
NOTE:	As defined in [H222_MP2TS].
RAP	Random Access Point
SbS	Side-by-Side
SC	Service Compatible
SEI	Supplemental Enhancement Information
NOTE:	As defined in [H264_AVC].
SI	Service Information
TaB	Top-and-Bottom

4 Frame compatible plano-stereoscopic 3DTV services in DVB delivery systems

Figure 1 depicts the scope of the present document, highlighted by the grey area, and the general concept of the compatibility of DVB frame compatible plano-stereoscopic 3DTV services with HDTV services over the encoding, transmission, and decoding stages of operation in a DVB delivery system. It shows, as a hypothetical example, a frame compatible plano-stereoscopic 3DTV service being multiplexed with a conventional HDTV service into a single MPEG-2 Transport Stream for delivery to a population of IRDs, some of which are 3DTV capable (as defined in the present document), and some of which are HDTV capable, i.e. not 3DTV capable.

The present document defines signalling for frame compatible plano-stereoscopic 3DTV services and deals with the handling of DVB subtitles for use with these services.

The delivery system for frame compatible plano-stereoscopic 3DTV services defined in the present document is intended to be applicable for any broadcast or delivery channel that uses the DVB MPEG-2 Transport Stream to carry DVB services, as specified in [TS101154], hence no delivery-system specific features are defined.

The features of HDTV services and IRDs, as defined in [TS101154], are not impacted by the present document. They are depicted in the scope diagram due to the fact that frame compatible plano-stereoscopic 3DTV service delivery utilises the same HDTV infrastructure, in certain valid use cases even including a HDTV IRD that has no 3DTV service cognisance.

While the compatibility with HDTV infrastructure and content formats enables the rapid and convenient roll-out of 3DTV services due to the transparent re-use of the existing HDTV delivery infrastructure, there are potentially also complications that need to be addressed around 3DTV service configuration and their co-existence with HDTV services within the delivery system.

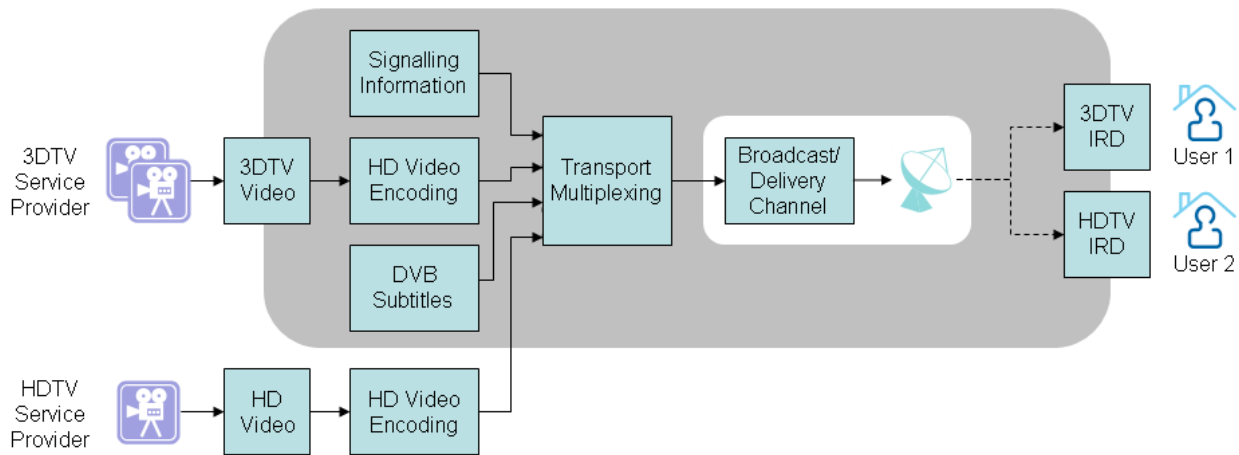

Figure 1 Scope of the frame compatible plano-stereoscopic 3DTV specification

The following sub-sections discuss informatively various aspects of frame compatible plano-stereoscopic 3DTV services and compliant IRDs.

Subsequent sections specify normatively the features of the frame compatible plano-stereoscopic 3DTV delivery system, also referring to revised versions of relevant existing DVB specifications that have been updated to include tools for frame compatible plano-stereoscopic 3DTV service delivery. These are the codecs usage specification for services that use the MPEG-2 Transport Stream ([TS101154]), the DVB SI specification ([EN300468]), and the DVB subtitles specification ([EN300743]).

4.1 3DTV services

A frame compatible plano-stereoscopic 3DTV service differs from an HDTV service in that the video component of the 3DTV service is a frame compatible plano-stereoscopic video format bitstream, and that the 3DTV service carries the 3DTV service signalling as specified in the present document. The frame compatible plano-stereoscopic 3DTV video bitstream conforms to HDTV video format requirements, so that the video frame encoder does not necessarily need to be cognisant of the frame compatible plano-stereoscopic 3DTV video format, apart from the video layer signalling. Associated audio and ancillary content streams are in the same formats as with DVB HDTV services.

For the purpose of discussing the various service configuration and co-existence scenarios, various generic forms of 3DTV service are defined informatively:

- The “24/7” 3DTV service, i.e. a 3DTV service that operates permanently in 3DTV mode;
- The “time-exclusive” 3DTV service, i.e. a 3DTV service that operates for only a certain fixed time (e.g. daily, weekly), and whose network resources are relinquished for use by another service at other times;
- The “predominant” 3DTV service, i.e. a service that contains predominantly 3DTV format content, but occasionally switches to HDTV mode;
- The “composite” 3DTV service, i.e. a service that has an arbitrary mix of HDTV and 3DTV format content;
- The “occasional” 3DTV service, i.e. a service that contains predominantly HDTV content, but occasionally switches to 3DTV mode.

The present document provides signalling tools (see section 6) to cater for all of these types of 3DTV service when they are in the form of frame compatible plano-stereoscopic 3DTV services.

Figure 2 depicts a hypothetical timeline of various types of DVB service, carrying various types of events, for the purposes of introducing the aspects specified in the present document, and the issues around the co-existence of frame compatible plano-stereoscopic 3DTV services with HDTV services.

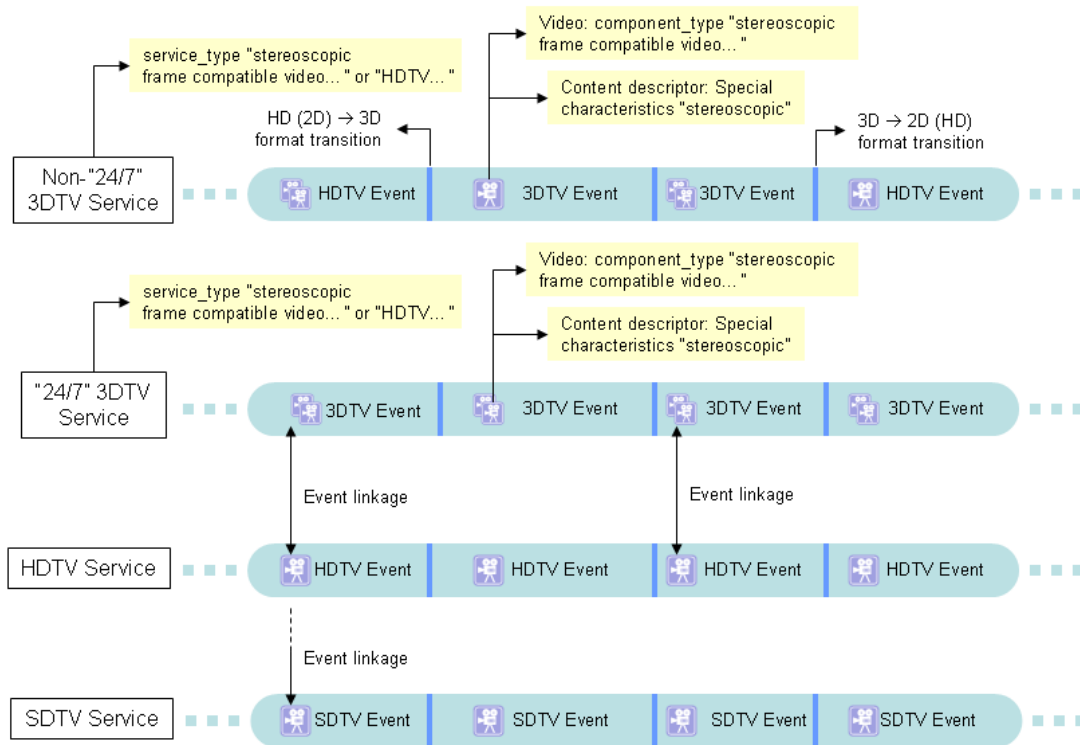

Figure 2 Frame compatible plano-stereoscopic 3DTV service scenarios

A 3DTV service is defined as a DVB service that is able to carry 3DTV events. Although new service_type code values are specified for frame compatible plano-stereoscopic 3DTV services, it should be noted that a 3DTV service may be signalled instead with a service_type code allocation of “advanced codec HD” service under certain circumstances, at the discretion of the service provider, as described in section 6.3.

A 3DTV event is defined as a DVB service event that contains a frame compatible plano-stereoscopic 3DTV format video stream, as specified in section 5.1. The permitted HD video encoding parameters (codec, resolution, and frame rate) for frame compatible plano-stereoscopic 3DTV services are also specified below in section 5.1.

Signalling for frame compatible plano-stereoscopic 3DTV services is described in section 6.

For the 3DTV service types that switch between 3DTV and HDTV modes, the video format transitions that occur when such a switch is performed (from a frame compatible plano-stereoscopic 3DTV video format to an HDTV video format, or vice versa) should be signalled as specified in section 6.5, in order to ensure consistent and reliable behaviour in the 3DTV IRD.

As well as the 3DTV specific service signalling per se, the existing event linkage SI has been extended to allow more convenient event linkage signalling scenarios with the increased number of different service types, i.e. now including 3DTV services. This aspect is specified in section 6.3.

In addition to the normal modes of operation of frame compatible plano-stereoscopic 3DTV services, Annex B provides informative guidelines on possible modes of operation of frame compatible plano-stereoscopic 3DTV services that give service compatible operation with HDTV services under certain conditions.

4.2 3DTV IRDs

At the time of publication of the present document there is already a significant population of frame compatible plano-stereoscopic 3DTV capable display devices in the field, enabling their users to enjoy 3DTV content from sources other than DVB delivery systems. These displays are not (yet) 3DTV IRDs themselves, because they are not cognisant of the 3DTV service signalling. Some of these devices will be able to be upgraded to be 3DTV service cognisant, but it is likely that many will not be upgraded, or not be able to be upgraded.

It can be expected that, with time, more and more HDTV display devices that support the frame compatible plano-stereoscopic 3DTV video formats and signalling will be introduced into the market, thereby gradually increasing the

proportion of frame compatible plano-stereoscopic 3DTV capable displays among the total population of HDTV displays. This timeline might play a part in service providers' decisions about how to manage frame compatible plano-stereoscopic 3DTV service signalling, in particular whether such services adopt a 3DTV or an HDTV service_type code, as described in section 6.4.

Due to the various capabilities with respect to 3DTV, and the different forms of IRD (e.g. STB or integrated TV), there are several scenarios for the reception of frame compatible plano-stereoscopic 3DTV services, and the co-existence of frame compatible plano-stereoscopic 3DTV compliant IRDs with existing HDTV (i.e. non-3DTV) equipment. Figure 3 depicts the predominant scenarios.

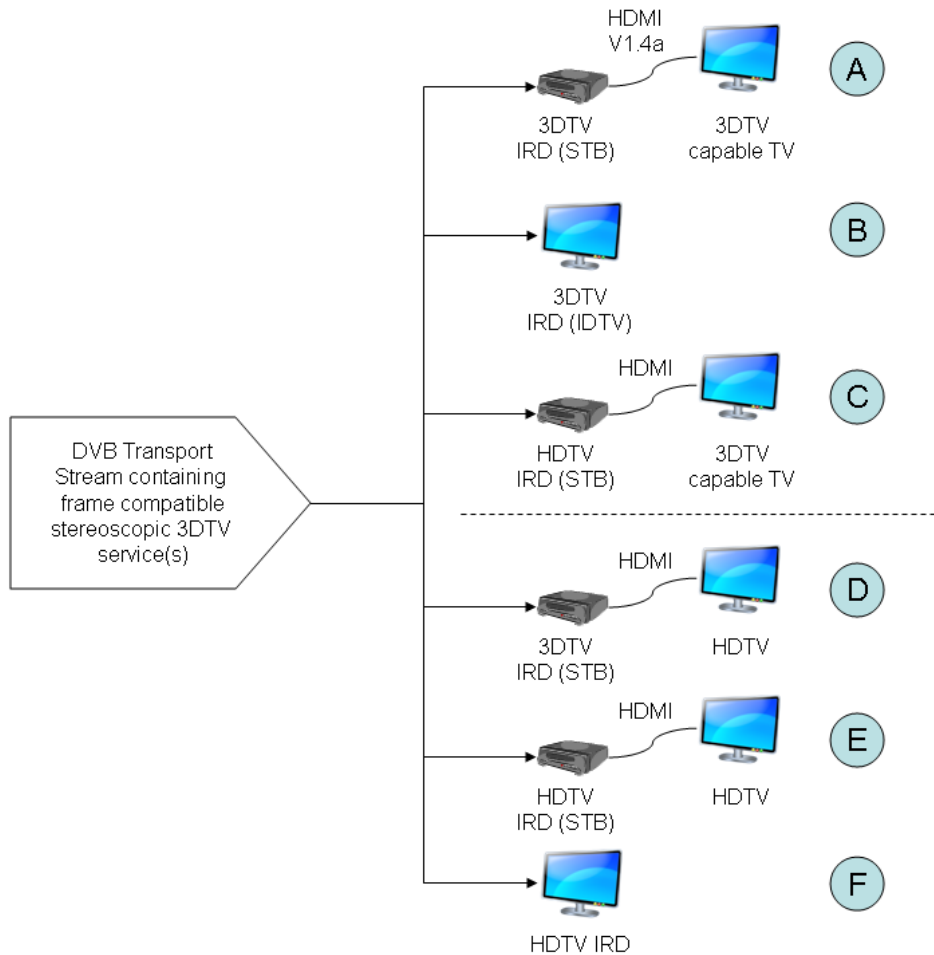

Figure 3 Frame compatible plano-stereoscopic 3DTV IRD scenarios

3DTV IRD scenario A: The user has a 3DTV compliant IRD (STB) connected to a 3DTV capable display device via HDMI V1.4a. The user receives 3DTV services via the STB.

3DTV IRD scenario B: The user has a 3DTV compliant IRD in the form of an IDTV, which receives 3DTV services directly from the delivery channel.

3DTV IRD scenario C: The user has an HDTV, i.e. non-3DTV compliant IRD (STB), connected via HDMI to an 3DTV capable display device. The user receives 3DTV services via the STB, even though the STB is not 3DTV cognisant itself. Unless the STB is able to be upgraded to be 3DTV cognisant, i.e. capable of recognising frame compatible plano-stereoscopic 3DTV services and signalling the carriage of the corresponding 3DTV video formats on the HDMI output, the STB is not able to signal the reception of a 3DTV service via its HDMI output, and the user must switch the TV to 3DTV viewing mode manually.

IRD scenarios A, B and C are the meaningful scenarios for the delivery of frame compatible plano-stereoscopic 3DTV services to the consumer. Further scenarios are described in order to highlight some 3DTV and HDTV service co-existence issues.

3DTV IRD scenario D: The user has a 3DTV compliant IRD (STB), connected via HDMI to a non-3DTV compliant HDTV set. Naturally it is not possible for the user to properly render the 3DTV services that might be able to be

received on the 3DTV capable STB. The 3DTV compliant IRD (STB) may be able to extract a 2D version of the 3DTV service for display on the HDTV display device by selectively cropping and upscaling the left view of the frame compatible plano-stereoscopic 3DTV service video content.

3DTV IRD scenario E: The user has an HDTV compliant, i.e. non-3DTV compliant IRD (STB), connected via HDMI to a non-3DTV compliant HDTV set. Again, in this scenario it is not possible for the user to receive the 3DTV services.

3DTV IRD scenario F: The user has an HDTV, i.e. non-3DTV compliant IRD (IDTV). Again, in this scenario it is not possible for the user to receive the 3DTV services, but this scenario is included in order to highlight some 3DTV and HDTV service co-existence issues.

In IRD scenarios E and F, if the HDTV IRD is made to be 3DTV cognisant, i.e. is able to identify frame compatible plano-stereoscopic 3DTV services and the frame compatible video format used, then it could selectively crop and upscale the left view of the frame compatible plano-stereoscopic 3DTV service video content and output a 2D video signal that is appropriate for its own display capabilities, or for the capabilities of the connected display.

5 Video and audio codecs usage

This section profiles [TS101154] to specify the video and audio codecs usage for frame compatible plano-stereoscopic 3DTV services.

5.1 Video

This section specifies the video formats for frame compatible plano-stereoscopic 3DTV services and the requirements on frame compatible plano-stereoscopic 3DTV IRDs.

Since HDMI V1.4a [HDMI] sets a precedent on frame compatible plano-stereoscopic 3DTV formats already supported by consumer display devices in the field, the formats specified for 3DTV services match the specified formats able to be carried by the HDMI connection, subject to the constraints of the existing HDTV delivery system.

Frame compatible plano-stereoscopic 3DTV services shall apply video coding according to the following clauses:

- a) *Frame compatible plano-stereoscopic 3DTV services shall use the H.264/AVC video codec [H264_AVC] for the coding of video content.*
- b) *The frame compatible plano-stereoscopic video format used for 3DTV services shall be either the Side-by-Side (SbS) or Top-and-Bottom (TaB), as specified below in combination with the allowed frame rates and picture resolutions.*

NOTE 1: Annex A provides an informative definition of the 3DTV frame compatible video formats, the pre-processing of source 3DTV video material in order to generate these formats, and of the post-processing required in the IRD in order to regenerate the left-eye and right-eye views from the decoded frame compatible video stream.

- c) *Frame compatible plano-stereoscopic 3DTV services shall apply sub-sampling (horizontal sub-sampling for the SbS frame compatible format, and vertical sub-sampling for the TaB frame compatible format) to the original full-resolution left-eye and right-eye views in order to generate the half-resolution left and right views.*

NOTE 2: These are the only sub-sampling methods mandated by [HDMI], hence they can be relied upon to be supported by 3DTV capable display devices when connected to a frame compatible plano-stereoscopic 3DTV IRD via an HDMI connection.

- d) *Frame compatible plano-stereoscopic 3DTV service video content shall be with 16:9 aspect ratio.*
- e) *Frame compatible plano-stereoscopic 3DTV services and IRDs shall comply with the common specifications for all H.264/AVC IRDs and bitstreams as defined in section 5.5 of [TS101154], and with the extension on frame compatible plano-stereoscopic 3DTV as defined in Annex H of [TS101154].*
- f) *Frame compatible plano-stereoscopic 3DTV services are divided into those applicable to 25Hz and to 30Hz video system environments, as is the case with the existing SD and HD format specifications in [TS101154].*

- 25Hz 3DTV services and IRDs shall comply with the specifications of 25Hz H.264/AVC HDTV IRDs and bitstreams as defined in section 5.7 of [TS101154], and with the provisions on 25Hz 3DTV services and IRDs in the extension on frame compatible plano-stereoscopic 3DTV in Annex H of [TS101154].
- 30Hz 3DTV services and IRDs shall comply with the specifications of 30Hz H.264/AVC HDTV IRDs and bitstreams as defined in section 5.7 of [TS101154], and with the provisions on 30Hz 3DTV services and IRDs in the extension on frame compatible plano-stereoscopic 3DTV in Annex H of [TS101154].

g) 25Hz frame compatible plano-stereoscopic 3DTV services may use the following video formats:

- 720p @ 50Hz Top-and-Bottom (TaB);
- 720p @ 50Hz Side-by-Side (SbS);
- 1080i @ 25Hz Side-by-Side (SbS).

NOTE 3: The 720p @ 50Hz Side-by-Side format is an optional format for compliance with [HDMI]. Some 3DTV capable display devices might not support this 3DTV video format.

h) 30Hz frame compatible plano-stereoscopic 3DTV services may use the following video formats:

- 720p @ 59,94 / 60 Hz Top-and-Bottom (TaB);
- 720p @ 59,94 / 60 Hz Side-by-Side (SbS);
- 1080i @ 29,97 / 30 Hz Side-by-Side (SbS);
- 1080p @ 23,98 / 24 Hz Top-and-Bottom (TaB);
- 1080p @ 23,98 / 24 Hz Side-by-Side (SbS).

NOTE 4: The 720p @ 59,94 / 60 Hz Side-by-Side format and the 1080p @ 23,98 / 24 Hz Side-by-Side format are optional formats for compliance with [HDMI]. Some 3DTV capable display devices might not support these 3DTV video formats.

NOTE 5: As described in the previous section, the 3DTV video content, in the form of a frame compatible video sequence, is encoded with an HDTV video encoder that does not need to be cognisant of the frame compatible format of the video stream. The 3DTV video content may pass through the same picture encoding, transmission and picture decoding stages as a conventional HDTV video stream.

i) Video layer signalling as specified in section 6.4 shall be applied in order to differentiate frame compatible plano-stereoscopic 3DTV video streams from conventional HDTV video streams.

Frame compatible plano-stereoscopic 3DTV compliant IRDs shall comply with the following clauses:

- a) 3DTV IRDs shall support 16:9 aspect ratio for the reception of frame compatible plano-stereoscopic 3DTV services.
- b) the 25Hz frame compatible plano-stereoscopic 3DTV IRD shall support the following video formats:
- 720p @ 50Hz Top-and-Bottom (TaB);
 - 720p @ 50Hz Side-by-Side (SbS);
 - 1080i @ 25Hz Side-by-Side (SbS).

NOTE 6: The 720p @ 50Hz Side-by-Side format is an optional format for compliance with [HDMI]. Some 3DTV capable display devices might not support this 3DTV video format.

c) the 30Hz frame compatible plano-stereoscopic 3DTV IRD shall support the following video formats:

- 720p @ 59,94 / 60 Hz Top-and-Bottom (TaB);
- 720p @ 59,94 / 60 Hz Side-by-Side (SbS);
- 1080i @ 29,97 / 30 Hz Side-by-Side (SbS);

- 1080p @ 23,98 / 24 Hz Top-and-Bottom (TaB);
- 1080p @ 23,98 / 24 Hz Side-by-Side (SbS).

NOTE 7: The 720p @ 59,94 / 60 Hz Side-by-Side format and the 1080p @ 23,98 / 24 Hz Side-by-Side format are optional formats for compliance with [HDMI]. Some 3DTV capable display devices might not support these 3DTV video formats.

5.2 Audio

No particular usage requirements for frame compatible plano-stereoscopic 3DTV services exist for audio, so that the same audio codec usage applies for frame compatible plano-stereoscopic 3DTV as for HDTV services as specified in [TS101154].

6 Signalling

This section specifies the signalling associated with frame compatible plano-stereoscopic 3DTV services. This signalling consists of the following components:

- Signalling in the transport layer, using MPEG-2 PSI and DVB Service Information (SI);
- Signalling in the video stream, using the H.264/AVC Supplemental Enhancement Information (SEI);
- Signalling in the subtitles, as defined in an extension to the DVB subtitles specification [EN300743].

Figure 4 shows the various aspects of signalling specified for the carriage of frame compatible plano-stereoscopic 3DTV services in DVB delivery systems.

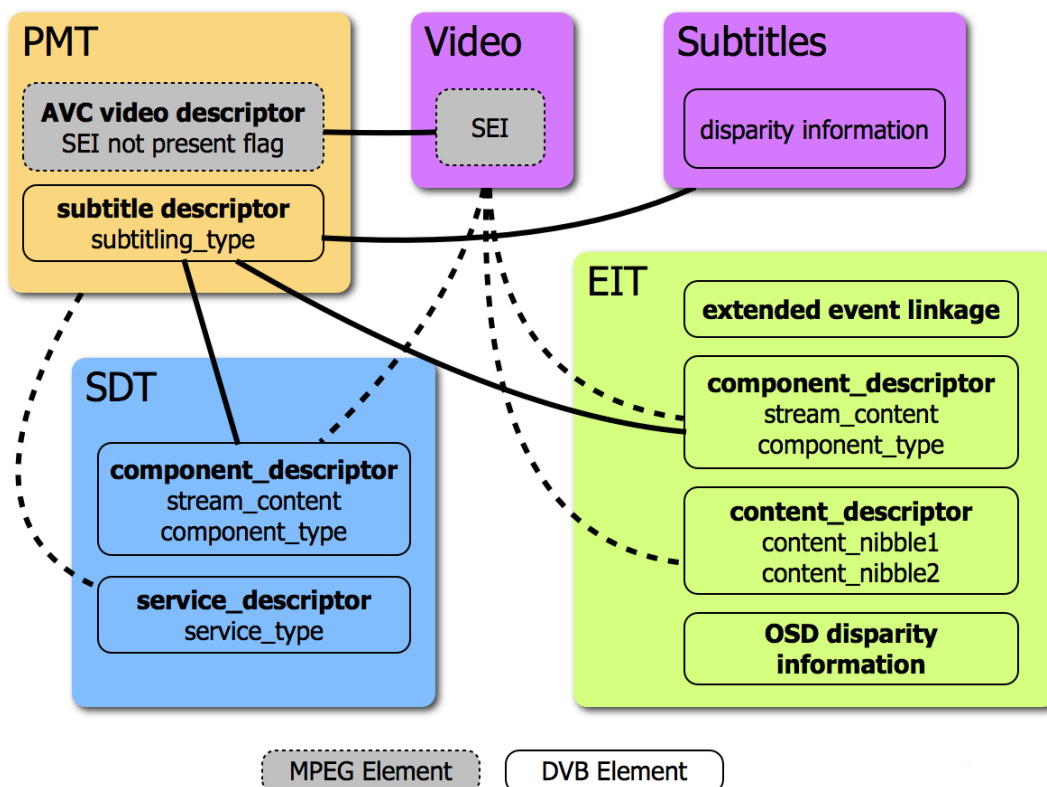

Figure 4 Elements of frame compatible plano-stereoscopic 3DTV signalling

Since, by definition, frame compatible plano-stereoscopic 3DTV services are carried in the same way as an HDTV service, frame compatible plano-stereoscopic 3DTV services and IRDs shall comply with the system layer specifications related to all H.264/AVC IRDs and bitstreams as defined in section 4 of [TS101154].

PSI and SI shall be used to signal the presence of 3DTV services in the MPEG-2 TS according to the normative statements expressed in the present section and using the referenced 3DTV related extensions as specified in [EN300468].

6.1 Programme Specific Information

A frame compatible plano-stereoscopic 3DTV service shall include the AVC_video_descriptor in the descriptor loop for the respective elementary stream entry in the PMT of the Transport Stream carrying that service.

The Frame_Packing_SEI_not_present_flag in the AVC_video_descriptor carried in the PMT, as specified in [H222_TMVC], shall be set according to the presence of the frame packing arrangement SEI message in the coded video sequence. The usage of the frame packing arrangement SEI message in the coded video sequence is specified in section 6.4.

The Frame_Packing_SEI_not_present_flag in the AVC_video_descriptor shall be set to 0 to signal the presence of frame packing arrangement SEI message in the coded video sequence during carriage of a frame compatible plano-stereoscopic 3DTV video format.

The Frame_Packing_SEI_not_present_flag in the AVC_video_descriptor may be set to 0 to signal the presence of frame packing arrangement SEI message in the coded video sequence also during carriage of an HDTV video format.

The Frame_Packing_SEI_not_present_flag in the AVC_video_descriptor may be set to 1, to signal that no frame packing arrangement SEI messages are being conveyed in the coded video sequence, only when an HDTV video format is in use, and when no format transition to a frame compatible plano-stereoscopic 3DTV video format is about to occur, and when no format transition to a frame compatible plano-stereoscopic 3DTV video format has just occurred. Section 6.5 specifies the detailed behaviour of PSI and video layer signalling around such video format transitions.

6.2 Service Information

The DVB SI specification [EN300468] has been extended to include several signalling features required for the implementation of frame compatible plano-stereoscopic 3DTV services and delivery systems. This section summarises this set of extensions while formulating normatively their usage in conjunction with frame compatible plano-stereoscopic 3DTV services.

In case of any doubt about the consistency between normative statements in [EN300468] and the repeated statements herein, the corresponding normative statement [EN300468] shall take precedence.

6.2.1 Service type

Dedicated SI service types have been defined in section 6.2.33 of [EN300468] for use with SDT associated with frame compatible plano-stereoscopic 3DTV services, for:

- Advanced codec frame compatible plano-stereoscopic HD digital television service (service_type code 0x1C);
- Advanced codec frame compatible plano-stereoscopic HD NVOD time-shifted service (service_type code 0x1D);
- Advanced codec frame compatible plano-stereoscopic HD NVOD reference service (service_type code 0x1E).

While these newly defined service type codes are intended for use with 3DTV services, there are use cases whereby 3DTV services would rather adopt the existing service type codes for “advanced codec HD services” (types 0x19, 0x1A, and 0x1B). The decision whether to use the newly defined “advanced codec frame compatible plano-stereoscopic HD” service type codes or the existing “advanced codec HD” service type codes lies with the service provider, as it depends on the use case for the 3DTV service.

IRDs may use this information to highlight frame compatible plano-stereoscopic 3DTV services in the EPG.

Usage of the new service types with the various types of frame compatible plano-stereoscopic 3DTV services introduced in section 4.1, and the impact on the various IRD scenarios introduced in section 4.2 is discussed in section 6.3.

6.2.2 Component type

The component descriptor has been extended to include the frame compatible plano-stereoscopic 3DTV video format definitions, as specified in section 6.2.8 of [EN300468].

New SI component types, for stream content type 0x05, have been defined for the frame compatible video component formats available for use with frame compatible plano-stereoscopic 3DTV services. These are:

- H.264/AVC plano-stereoscopic frame compatible high definition video, 16:9 aspect ratio, 25 Hz, Side-by-Side (component type code 0x80);
- H.264/AVC plano-stereoscopic frame compatible high definition video, 16:9 aspect ratio, 25 Hz, Top-and-Bottom (component type code 0x81);
- H.264/AVC plano-stereoscopic frame compatible high definition video, 16:9 aspect ratio, 30 Hz, Side-by-Side (component type code 0x82);
- H.264/AVC plano-stereoscopic frame compatible high definition video, 16:9 aspect ratio, 30 Hz, Top-and-Bottom (component type code 0x83).

Frame compatible plano-stereoscopic 3DTV services should carry the component_descriptor in the EIT and apply the appropriate component_type according to the video format being used.

24Hz frame rate video content shall use the appropriate frame compatible video component type as defined for 30Hz content.

Further aspects around the usage of the new component types with the various types of frame compatible plano-stereoscopic 3DTV services introduced in section 4.1, and the impact on the various IRD scenarios introduced in section 4.2 is discussed in section 6.3.

6.2.3 Content descriptor

The content descriptor has been extended to enable 3DTV services to signal that an event is in a plano-stereoscopic 3DTV format, as specified in section 6.2.9 of [EN300468].

The “special characteristics” content class has been extended to include the following event characteristic for 3DTV events:

- Stereoscopic (content_nibble_level_2 code 0x4).

Frame compatible plano-stereoscopic 3DTV services may apply this event characteristic in the content_descriptor in the EIT.

Frame compatible plano-stereoscopic 3DTV IRDs may use this information to highlight such events in the EPG.

6.2.4 Linkage descriptor

The SI linkage descriptor, specified in section 6.2.19 of [EN300468], has been extended to include an additional linkage type “extended event linkage”. This is specified in section 6.2.19.3 of [EN300468].

6.2.5 Video depth range descriptor

The video depth range descriptor, specified in section 6.4.12 of [EN300468], is designed to accommodate a choice of methods to convey depth or disparity information for 3DTV content. This information may be used by the 3DTV IRD for the depth positioning of any of its own on-screen graphics overlays on top of the 3DTV content currently being displayed. General aspects of the placement of on-screen graphics on top of 3DTV video content are outlined in section 7.

In the current version of [EN300468] only one method is specified, namely the production disparity hint information, consisting of minimum and maximum disparity values occurring with the associated 3DTV video content event or service.

In the production disparity hint, disparity is measured as a number of pixels on a reference screen with a horizontal resolution of 11520 pixels.

Table 1 shows how the disparity on the reference screen is converted to the disparity on an actual screens corresponding to the horizontal resolutions of the frame compatible plano-stereoscopic 3DTV video formats.

$(\text{DISPARITY} / 11520) \times$	Horizontal screen resolution	=	Pixel disparity
	1280		$\text{DISPARITY} / 9$
	1440		$\text{DISPARITY} / 8$
	1920		$\text{DISPARITY} / 6$

Table 1 Conversion of disparity on reference screen

Knowledge of both the minimum and maximum disparity may be used for purposes other than the display of on-screen graphics. This information may also be used by the receiver to improve the 3DTV viewing experience by shifting the 3DTV image to a position that is optimal for the screen and the viewer.

The usage of the video depth range descriptor with frame compatible plano-stereoscopic 3DTV services is optional, and its support in the frame compatible plano-stereoscopic 3DTV IRD is optional.

This descriptor may be present in the SDT or EIT. If present in the SDT, then it identifies the video depth range type for the service. If present in the EIT, then it overrides the same video depth range type that may be present in the SDT of that service.

The video depth range descriptor should not be included in the service signalling if the minimum and maximum disparity values are either unknown or unreliable. If a receiver uses incorrect values, the results can be uncomfortable for the viewer.

6.3 Service Signalling scenarios

Table 2 below shows the usage of the attributes specified in previous sub-sections for the 3DTV service classes listed in Section 4.1. The table is not intended to represent an exhaustive list of possibilities nor specify the only signalling option for each form of 3DTV service. Rather, it is meant as guidance and for raising awareness of possible issues that need to be considered with the deployment of frame compatible plano-stereoscopic 3DTV services.

IRDs already existing in the field might not recognise the newly defined 3DTV service types, or be able to be upgraded to do so. Usage of the new service types has an impact with existing HDTV IRDs, and might impact IRD scenario C, if the HDTV IRD fails to pass through frame compatible plano-stereoscopic 3DTV services to the 3DTV capable display device connected to it via HDMI, even when that display is able to receive 3DTV content.

Referring to 3DTV IRD scenario C introduced in section 4.2, the HDTV compliant IRD in the form of a STB should ideally pass through any frame compatible plano-stereoscopic 3DTV service to the 3DTV capable display device connected to it via HDMI, to enable the user to receive that service, in spite of the fact that the user might need to switch the display device to 3DTV mode manually. In controlled environments, where for example the 3DTV service provider knows how the entire IRD population receiving the 3DTV service is configured, this will not be a concern.

Service Form	SDT		EIT (see NOTE 4)	3DTV IRD Scenarios A, B		3DTV IRD Scenario C		Comments
	Service Type	Component Type	Component Type	Service listing	Display	Service listing	Display	
“Occasional” 3DTV service	HDTV	‘3DTV’	‘2D HDTV’, sometimes ‘3DTV’	OK	OK	Service might not be listed	Service might not be displayed	This signalling is NOT RECOMMENDED , (see NOTE 1)
	HDTV	Not present or ‘2D HD’	‘2D HDTV’, sometimes ‘3DTV’	OK	OK	OK	OK	This is the RECOMMENDED signalling: 3DTV events are signalled via EIT
“24/7”, “Time- exclusive” and “Predominant” 3DTV services (see NOTE 3)	3DTV	‘3DTV’	‘3DTV’, sometimes ‘2D HDTV’	OK	OK	Service might not be listed	Service might not be displayed	This signalling MAY BE used (see NOTE 2)
	3DTV	Not present	‘3DTV’, sometimes ‘2D HDTV’	OK	OK	Service might not be listed	Service might not be displayed	This is the RECOMMENDED signalling when legacy IRDs are intended to be excluded from receiving the 3DTV service

Table 2 Summary of frame compatible plano-stereoscopic 3DTV service signalling scenarios

NOTE 1: This signalling is not recommended because some legacy IRDs may use the component type in SDT to filter out services using codecs that the IRD does not support. This is a specified option in section 4.2.3.4 of [TS101211]. If legacy IRDs implement this feature, then frame compatible plano-stereoscopic 3DTV services signalled in this way are filtered out, even, as in this case, they consist mostly of 2D HDTV content. If broadcasters still want to use this signalling, then they should do so with care.

NOTE 2: This signalling may be used for certain cases where ‘legacy IRDs’ shall be excluded AND where it is known that the component type in the SDT will be parsed and acted upon (e.g. used as hints for channel change, etc...).

NOTE 3: Although foreseen as a “24/7” 3DTV-only channel, a broadcaster might need to insert a ‘2D HDTV’ event for different reasons, e.g.: technical problems, program schedule change, etc.

NOTE 4: It is assumed for 3DTV events that the content descriptor is set to “Stereoscopic”, hence not listed explicitly.

6.4 Video stream signalling

The coded video stream of a frame compatible plano-stereoscopic 3DTV service shall apply the frame packing arrangement supplemental enhancement information (SEI) message in order to signal the format of the video component of the frame compatible plano-stereoscopic 3DTV service. The video format used and signalled shall be one of the formats specified in section 5.1.

The coded video stream of a frame compatible plano-stereoscopic 3DTV service shall convey the frame packing arrangement SEI message with every frame of video, if the video is in a frame compatible plano-stereoscopic 3DTV format.

The setting of the frame_packing_arrangement_cancel_flag to ‘0’ signals that a frame compatible plano-stereoscopic 3DTV video format is being used, and the other fields of the descriptor signal the format of the frame compatible plano-stereoscopic 3DTV video stream and its other characteristics.

The setting of the `frame_packing_arrangement_cancel_flag` to '1' signals that a non-3DTV video format is being used, i.e. an HDTV video format.

The detailed usage of the frame packing arrangement SEI message syntax for use with frame compatible plano-stereoscopic 3DTV services video streams is specified in Annex H of [TS101154].

Frame compatible plano-stereoscopic 3DTV services that might switch between 3DTV and non-3DTV (i.e. HDTV) formats, are recommended to convey the frame packing arrangement SEI message also during the time of carriage of an HDTV format video stream, if this signalling tool is available in the encoder. Section 6.5 specifies the signalling methods for such video format transitions.

6.5 Video format transitions

A frame compatible plano-stereoscopic 3DTV service may switch video format between two of the frame compatible plano-stereoscopic video formats specified in section 5, or it may switch to or from one of the frame compatible plano-stereoscopic video formats to or from an HDTV video format (i.e. a non-frame compatible plano-stereoscopic 3DTV video format).

NOTE: A format switch between the Side-by-Side and Top-and-Bottom frame compatible formats is unlikely to be applied, and although such transitions are not forbidden, they are not recommended.

NOTE: A channel hop between two 3DTV services might include an inherent format switch that might cause additional channel hop delay in some cases.

A video format switch shall be applied only at a RAP with an IDR video frame.

Due to the lack of tight synchronisation between occurrences of the PMT in the Transport Stream and occurrences of pictures in the video stream, there is an inconsistency for a short time if the video format is switched during the running frame compatible plano-stereoscopic 3DTV service. The carriage of HDTV (i.e. non-3DTV) video format content usually means that the frame packing arrangement SEI message is not applicable. However, an IRD that is presented with such a format switch might not handle the transition correctly due to the temporary inconsistency with the information contained in the previous occurrence of the PMT. This is depicted in figure 5 with the example of a video format switch from 1080i @ 25Hz Side-by-Side frame compatible plano-stereoscopic 3DTV video to 1080i @ 25Hz HDTV video.

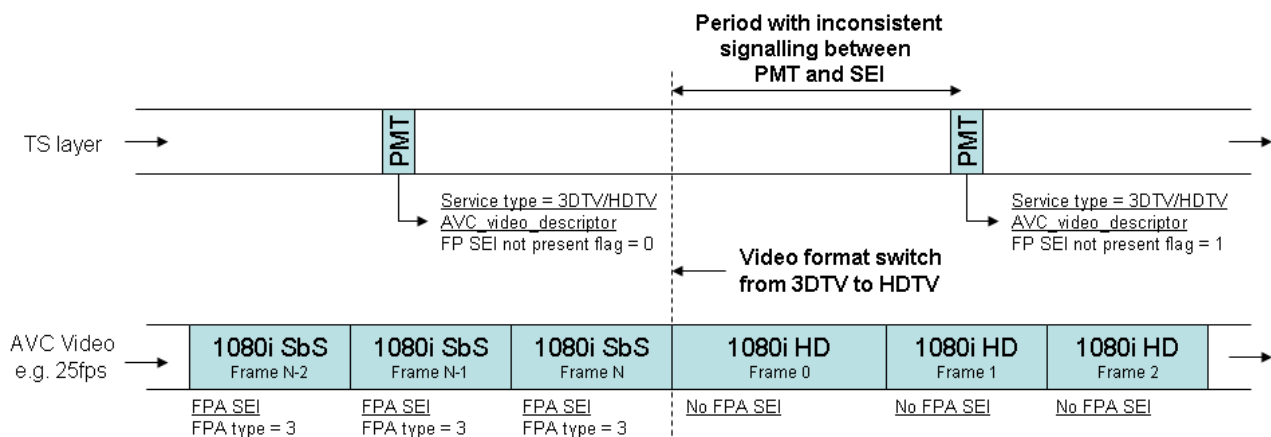

Figure 5 Example video format transition without transition assistance signalling

In this example there is an inconsistency between the information carried in the last occurrence of the PMT before the video format switch, and the information conveyed by the frame packing arrangement SEI message after the video format switch. This inconsistency could cause the IRD to assume the incorrect video format during the period of inconsistency, the length of which is not known due to the mentioned lack of tight synchronisation between the PMT and coded video pictures.

Format transition assistance signalling is defined that enables assurance of the robustness of the decoding process in the IRD. It is recommended that this format transition assistance signalling is applied when a frame compatible plano-stereoscopic 3DTV service includes periods of content in a non-3DTV video format.

The format transition assistance signalling consists of the inclusion of frame packing arrangement SEI messages also in the video stream containing HDTV format video content, with the field `frame_packing_arrangement_cancel_flag` set to '1' to signal affirmatively that no frame compatible plano-stereoscopic 3DTV video format is being transmitted currently.

Figure 6 depicts the example of a video format switch from 1080i @ 25Hz Side-by-Side frame compatible plano-stereoscopic 3DTV video to 1080i @ 25Hz HDTV video when the format transition assistance signalling is applied.

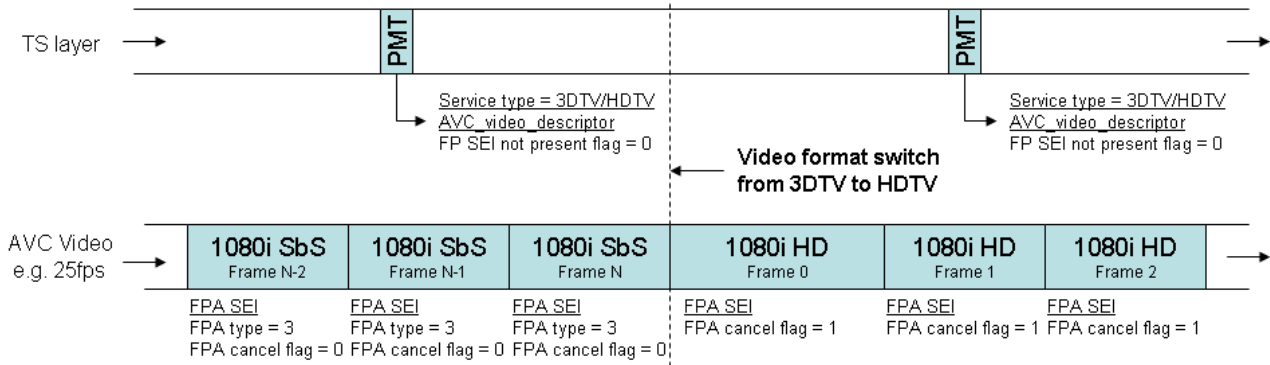

Figure 6 Example video format transition with transition assistance signalling

In order to maximise the robustness of the decoding process in the IRD, it is recommended that the frame compatible plano-stereoscopic 3DTV service applies the frame packing arrangement SEI message also during carriage of the HDTV format, at least for a period of two seconds before and after a format switch between the HDTV video format and the frame compatible plano-stereoscopic 3DTV video format.

When a video format transition occurs either to or from an HDTV video format, the the `frame_packing_arrangement_cancel_flag` in the frame packing arrangement SEI message should be set to '1', indicating that a non-3DTV video format is being carried, for a period of at least two seconds after the transition from a frame compatible plano-stereoscopic 3DTV video format to an HDTV video format has occurred, or for at least two seconds before the transition from an HDTV video format to a frame compatible plano-stereoscopic 3DTV video format will occur.

Carriage of the frame packing arrangement SEI message with `frame_packing_arrangement_cancel_flag` setting to '1' may persist during the complete duration of HDTV video format content, at the discretion of the service provider. As well as enhancing the robustness of the handling by the IRD of video format transitions within a frame compatible plano-stereoscopic 3DTV service, it also provides robustness in the case when the IRD hops from another service to a frame compatible plano-stereoscopic 3DTV service. In some circumstances it might be more convenient to continue to apply this signalling than to cease to convey it.

Figure 7 depicts the generic scenarios of frame compatible plano-stereoscopic 3DTV service format transitions, with the following characteristics of PMT and FPA SEI signalling mapped to the example video formats depicted:

- PMT 1 { `AVC_video_descriptor` with `frame_packing_SEI_not_present_flag` = '0' }
- PMT 2 { `AVC_video_descriptor` with `frame_packing_SEI_not_present_flag` = '1' }
- FPA SEI 1 { `frame_packing_arrangement_cancel_flag` = '0'; `frame_packing_arrangement_type` = '3' }
- FPA SEI 2 { `frame_packing_arrangement_cancel_flag` = '1' }
- FPA SEI 3 { `frame_packing_arrangement_cancel_flag` = '0'; `frame_packing_arrangement_type` = '4' }

Note that figure 7 is a large-scale diagram with respect to the time axis, so that no detail is shown as regards the inconsistencies between PMT and AVC SEI messages that arise at all video format transitions, and that the diagram depicts only those particular occurrences of "RAP with IDR picture" that occur at the video format transitions.

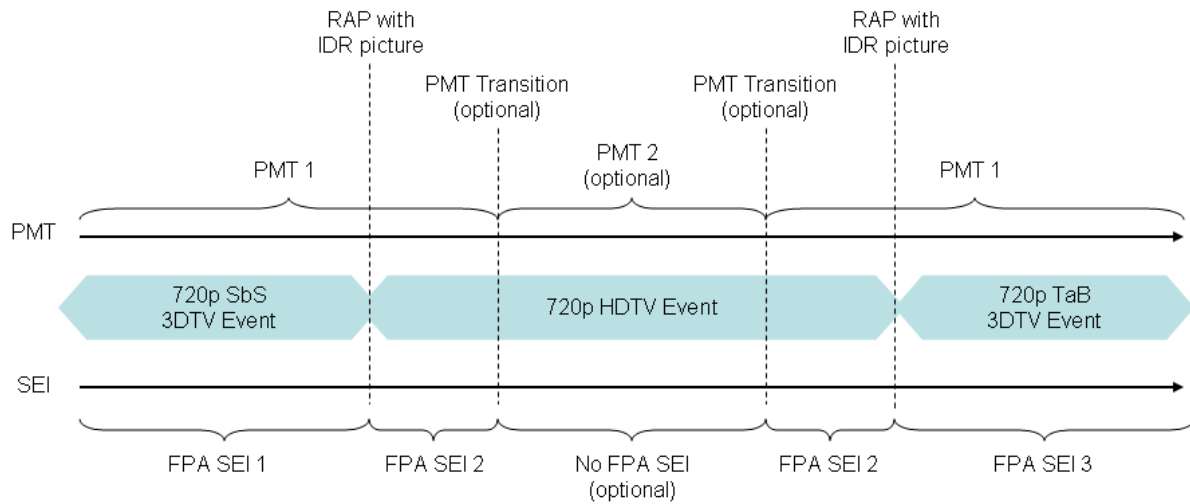

Figure 7 Generic scenarios of frame compatible plano-stereoscopic 3DTV service format transitions

In any case the frame packing arrangement SEI message signalling shall be consistent with the video format carried, and takes precedence over other signalling as regards video format.

The temporary inconsistencies with the PMT mentioned above may occur, and are alleviated by the application of format transition assistance signalling as specified in the present section.

7 Graphics and captions display (informative)

Special consideration needs to be given to the display of graphics and captions (including subtitles) over 3DTV video, in that they need to be positioned harmoniously within the three-dimensional scene, i.e. at a certain depth, in order not to impact detrimentally the 3DTV viewing experience. This section provides some background which might help better understand the applicable methods for on-screen graphics rendering over 3DTV video content.

7.1 On-screen graphics

During normal operation, a receiver may have to display some kind of on-screen graphics (e.g. display message or other content) to the viewer in response to an event caused by either the viewer, a device sub-system (such as the CI sub-system), or from the broadcast channel. The graphic may occupy the entire screen or just a part of it. During a non-3DTV transmission, displaying an on-screen graphic is just a question of video overlay and does not have any further consequence. During a 3DTV transmission, however, displaying that same on-screen graphic with the wrong depth can cause it to be unreadable. For example, if the graphic is placed at a certain screen depth and there is a solid object in the video that is closer to the viewer, then that on-screen graphic will appear to have “punched a hole” in the video. “Hole punching” can be avoided by knowing how close the objects come to the viewer, and then placing the on-screen graphics even closer. The results of this mechanism depend on the temporal granularity of the depth information available for the video objects. In any case, graphics should not be positioned too close to the viewer as this causes visual discomfort, since there is a comfort zone of depth within which on-screen graphics can be placed.

If no video object depth information is available, a possible way to keep the on-screen graphics overlays within the viewer’s comfort zone is to switch the video to 2D mode and to place the overlays at screen depth or in front of the screen.

Another possibility is to ‘push back’ the video, for which another parameter is required, namely how far behind the screen an object may be, or even better, where is infinity. Assuming a reference screen size and a viewing distance, the comfort zone extends from somewhere in front of the screen to somewhere behind the screen. For the majority of the time, all 3DTV objects should remain within this zone. The zone limits may be exceeded for short periods of time for specific editorial needs, such as short term visual impact. The extent of this zone behind this screen is not determined by a perceived distance, which may be infinity, but by the extent to which any viewer can be expected to fuse the image.

If all of the 3DTV content is well within the comfort zone for most of the time, then it may be possible to re-render the 3DTV content further backwards, away from the viewer. In doing so it may become possible now to place a graphics overlay closer to the viewer, while remaining within the comfort zone.

How far objects are in front or behind the screen can be expressed in terms of disparity. As specified in section 6.2.5, it is possible to apply the video depth range descriptor to frame compatible plano-stereoscopic 3DTV services and events in order to convey disparity information to the receiver.

7.2 Subtitles

As with SDTV and HDTV, subtitling remains an important component of a 3DTV service. Along with on-screen graphics, it is of crucial importance that subtitles are positioned accurately over 3DTV video content, in terms of both depth and of their timing, such that the 3DTV viewing experience is supported rather than degraded.

The specification for DVB subtitling systems [EN300743] has been revised to take into account frame compatible plano-stereoscopic 3DTV services, by including the means of signalling the disparity with which each provided subtitle caption is intended to be positioned by the 3DTV IRD.

A new segment, the Disparity Signalling Segment (DSS), is specified in section 7.2.7 of [EN300743]. This includes the definition of subregions within a region. Different disparity values can be transmitted for each subregion, enabling the placement of subtitles at varying depths within the region, and within the page. Disparity can be carried with sub-pixel accuracy, which enables optimal placing within the 3DTV scene. A default page disparity value is also carried in the DSS, used by decoders that are unable to apply different disparities to different regions on the screen page.

Temporal updates of disparity values for each defined sub-region can be carried with a temporal accuracy of periods of the 90kHz System Time Clock (STC). They can be carried in the subtitle PES packet stream as usual, or more efficiently grouped together using the disparity update sequence mechanism, as illustrated in Annex C of [EN300743].

Annex A: Frame compatible plano-stereoscopic 3DTV video formats (informative)

A frame compatible plano-stereoscopic video format means that the left-eye and right-eye images are arranged in a spatial multiplex which results in a composite image that can be treated like a conventional HDTV image by the receiver demodulator and compression decoder.

This annex provides an informative overview of the frame compatible video formats adopted for frame compatible plano-stereoscopic 3DTV. These formats form a subset of the formats possible to be compressed and signalled using H.264/AVC video coding [H264_AVC], and possible to be carried and signalled over an HDMI V1.4 connection [HDMI14a].

NOTE: The diagrams contained in this annex are illustrative and do not intend to depict accurately the video resolution or aspect ratio.

A.1 Side-by-Side frame compatible video format

The Side-by-Side (SbS) format is defined as the arrangement of the frame compatible spatial multiplex such that the horizontally anamorphic left-eye picture is placed in a spatial multiplex to occupy the first half of each line, and the right-eye picture is placed in the spatial multiplex to occupy the second half of each line.

The process for the generation of SbS format frame compatible plano-stereoscopic video is depicted in figure 8. This corresponds to the function “3DTV Video” in the 3DTV scope diagram in section 4 for a 3DTV service that uses the Side-by-Side frame compatible video format.

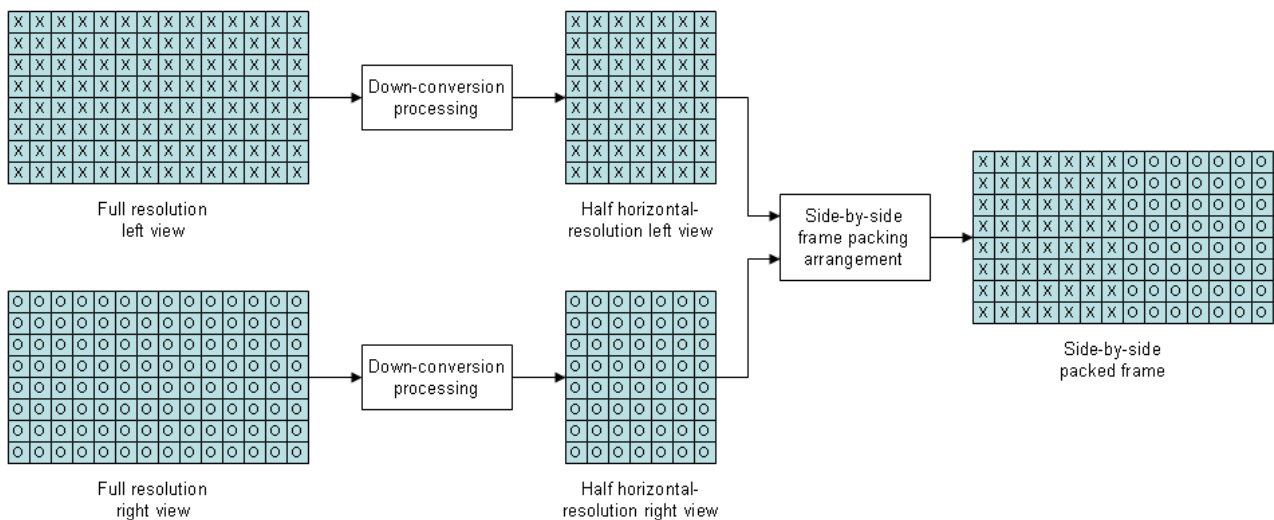

Figure 8 Side-by-Side video frame composition

The Side-by-Side frame compatible 3DTV video frame has the same format as a conventional HDTV video frame.

The decomposition and up-conversion process in the 3DTV IRD to re-generate the left-eye and right-eye views from the decoded Side-by-Side frame compatible format is depicted in figure 9.

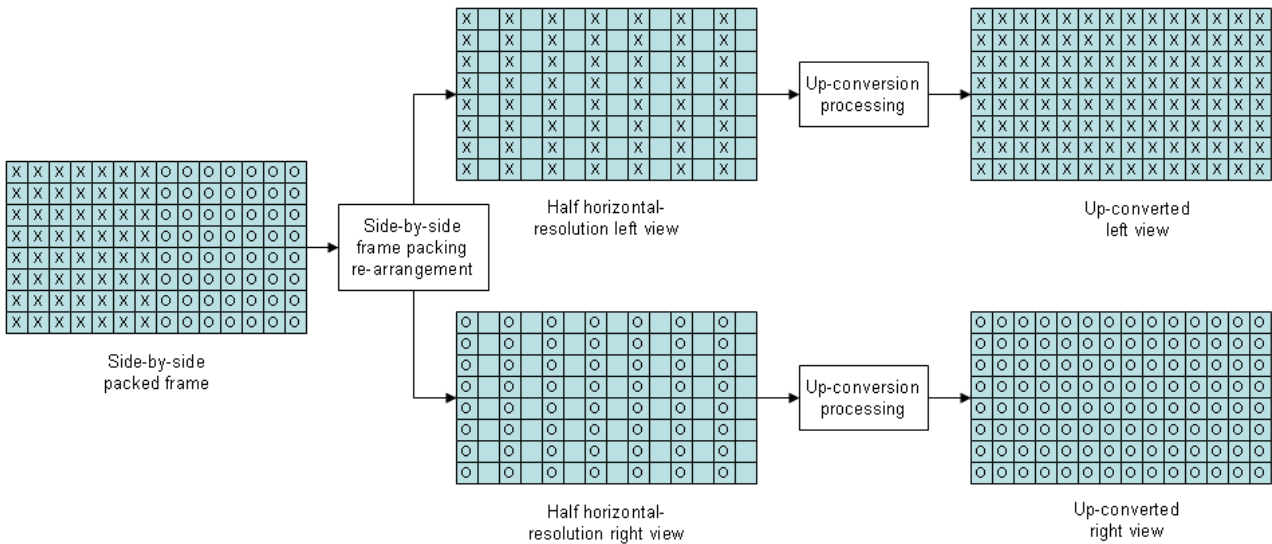

Figure 9 Side-by-Side decoded video frame decomposition

A.2 Top-and-Bottom frame compatible video format

The Top-and-Bottom (TaB) format is defined as the arrangement of the frame compatible spatial multiplex such that the vertically anamorphic left-eye picture is placed in the spatial multiplex to occupy the first (top) half of a single HDTV video frame, and the right-eye picture is placed in the spatial multiplex to occupy the second (bottom) half of a single HDTV video frame.

The process for the generation of TaB format frame compatible plano-stereoscopic video is depicted in figure 10. This corresponds to the function “3DTV Video” in the 3DTV scope diagram in section 4 for a 3DTV service that uses the Top-and-Bottom frame compatible video format.

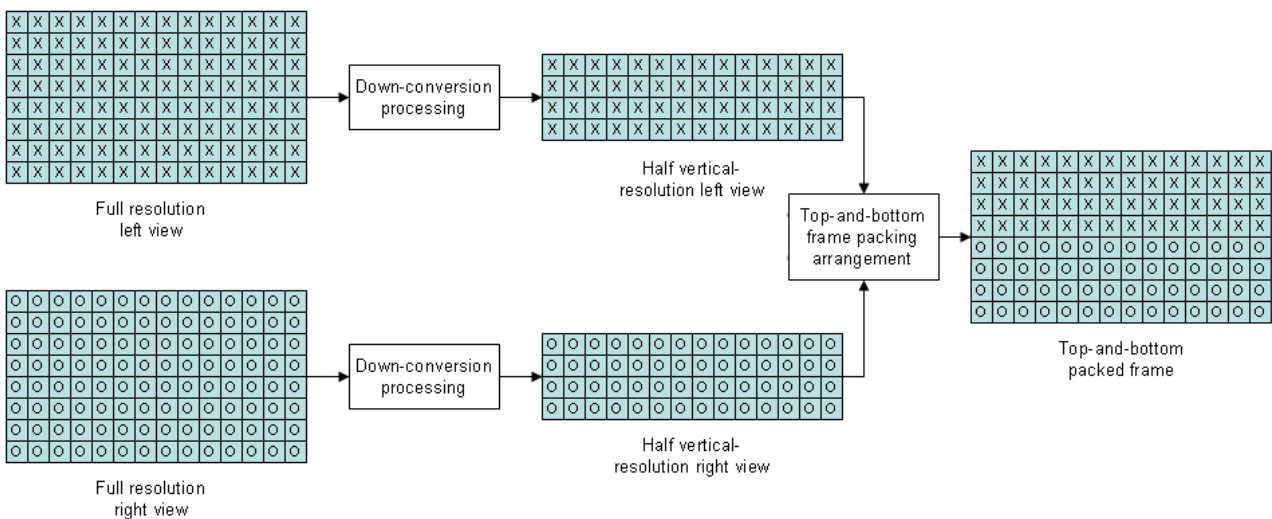

Figure 10 Top-and-Bottom video frame composition

The Top-and-Bottom frame compatible 3DTV video frame has the same format as a conventional HDTV video frame.

The decomposition and up-conversion process in the 3DTV IRD to re-generate the left-eye and right-eye views from the decoded Top-and-Bottom frame compatible format is depicted in figure 11.

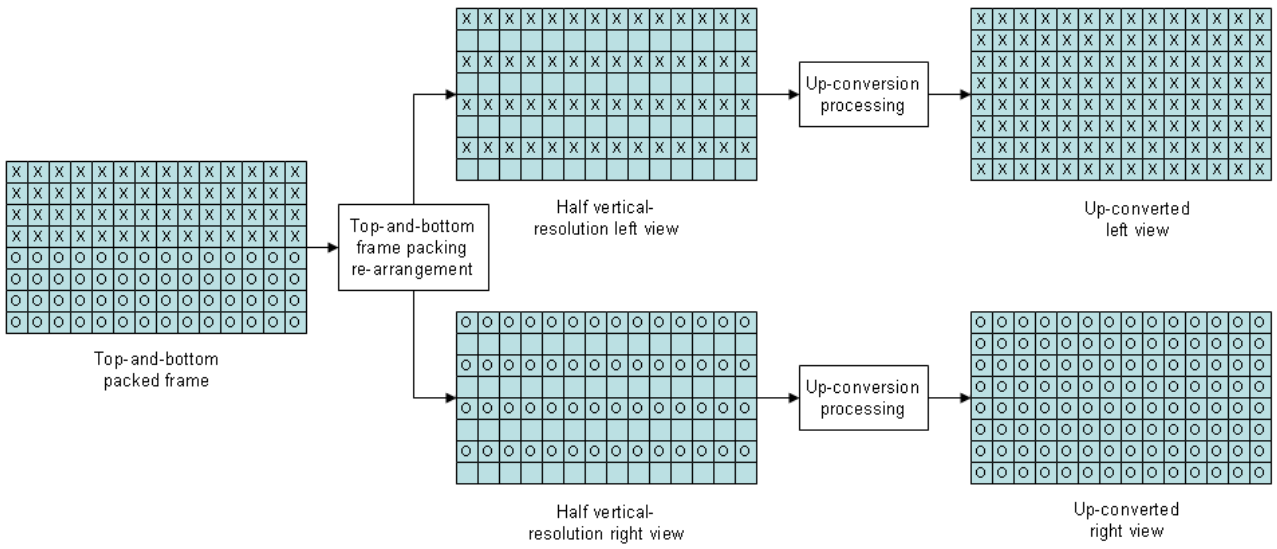

Figure 11 Top-and-Bottom decoded video frame decomposition

Annex B: HDTV service compatibility (informative)

This annex provides informative guidelines on possible modes of operation of frame compatible plano-stereoscopic 3DTV services that give service compatible operation with HDTV services under certain conditions. This kind of service compatibility is enabled by the HDTV decoder extracting the left view from the two views contained in the frame compatible plano-stereoscopic 3DTV service video stream, and up-scaling it to simulate the reception of an HDTV service. There are, however, inconsistencies with previously adopted signalling mechanisms that are inherent with some of these modes. The guidelines are detailed below.

Such service compatible modes could enable a service provider to transmit a single service that provides both frame compatible plano-stereoscopic 3DTV video and reduced-resolution HDTV video concurrently, whereas normally HDTV coverage with the same source content would be provided with a separate dedicated HDTV service.

Such a transmission could address 3DTV cognisant receivers and/or 3DTV incognisant receivers, whereby a 3DTV cognisant receiver is able to selectively output a video signal (either 3DTV or HDTV) that is appropriate for its own display capabilities, or for the capabilities of the connected display.

In the case of 3DTV cognisant receivers the service compatibility is achieved solely as a receiver implementation option, as mentioned in section 4.2 on IRD scenarios, and no modification to the transmitted signal is required compared to a frame compatible plano-stereoscopic 3DTV service transmission addressing only 3DTV receivers as specified in the main part of the present document, using the signalling specified in section 6.

For IRD scenario D described in section 4.2, the 3DTV IRD (STB), which is inherently 3DTV cognisant, could be implemented such that it applies such upscaling to the left view of the frame compatible plano-stereoscopic 3DTV service to provide the half-resolution video output to the HDTV display.

Likewise for IRD scenarios E and F, the HDTV IRD could be implemented to be 3DTV cognisant, such that it applies such upscaling to the left view of the frame compatible plano-stereoscopic 3DTV service to provide half-resolution HDTV video.

In some cases it might be possible to implement the support of the service compatible modes via an interactive application, on platforms that include access to the appropriate video processing functionality of the IRD.

For HDTV IRDs that are 3DTV incognisant and do not support such selective upscaling of frame compatible plano-stereoscopic 3DTV service video content, two signalling tools of the H.264/AVC video codec [H264_AVC] could be utilised in order to facilitate the service compatible modes – the *cropping rectangle* and the *sample aspect ratio*. These can be applied to the frame compatible plano-stereoscopic 3DTV service video content in order to attempt to force IRDs to apply upscaling to the left view, to output half-resolution HDTV video instead of the left and right views, as HDTV video.

To apply the cropping rectangle feature, the field *frame_cropping_flag* of the H.264/AVC *seq_parameter_set_data()* shall be set to '1'. Table 3 provides the settings of *frame_crop_offsets* (in terms of luma samples) and the *sample aspect ratio* for the frame compatible plano-stereoscopic 3DTV video formats specified in section 5.1 that are suitable for application of this signalling. These settings apply to both 25Hz and 30Hz video formats. Top-and-Bottom formats are not included and are not used with these service compatible modes, due to inherent limitations with the ability to perform vertical upscaling in many IRD implementations. The fields *frame_crop_top_offset* and *frame_crop_bottom_offset* take the same values as would be used for HDTV video.

Frame compatible plano-stereoscopic 3DTV video format	Frame crop left offset (luma samples)	Frame crop right offset (luma samples)	Sample aspect ratio
1920 x 1080i Side-by-Side	0	960	2:1
1280 x 720p Side-by-Side	0	640	2:1

Table 3 H.264/AVC frame crop signalling for the service compatible modes

It shall be noted when considering the application of the additional signalling for service compatible modes described above, that the compatibility of this signalling with HDTV IRDs and 3DTV capable products already deployed in the field is somewhat unpredictable, due to the following aspects:

- The additional signalling calls for cropping and upscaling capabilities of HDTV (i.e. non-3DTV cognisant) IRDs that exceed the minimum requirements defined in [TS101154].
- The application of this service compatibility mode signalling to a frame compatible plano-stereoscopic 3DTV service video stream in fact requires non-compliant behaviour of frame compatible plano-stereoscopic 3DTV IRDs for the rendering of the 3DTV service, since the service compatibility signalling effectively signals the discarding of the right view. This signalling might cause existing 3DTV capable IRDs (in IRD scenarios A, B and C as described in section 4.2) to fail to display a picture, or to display an incorrect picture, e.g., upscaled left-view video, rather than the complete frame compatible plano-stereoscopic 3DTV service video content.

NOTE: If new IRDs are intended to display 3DTV video from a frame compatible 3DTV service with service compatibility signalling as per this Annex, then the above inconsistency (“non-compliant behaviour”) might be overcome via suitable amendments of relevant specifications.

Software upgrades or similar measures to overcome these issues for IRDs already deployed in the field might not always be possible nor applicable.

Organisations intending to make use of this signalling should make provision to mitigate service reception problems due to IRDs that turn out to be incompatible, unless it has been verified that no compatibility problems will occur in the respective receiver population. This could take the form of information and advice to consumers in advance of commencing usage of these modes, and adequate guidance to viewers during transmissions using these modes, enabling viewers in possession of incompatible IRDs to revert to alternative services, e.g. redirection to an SD simulcast of the same event, via announcement messages, interactive applications and/or EPG information.

The editorial/production aspects of transmitting 3DTV and non-3DTV representations of the same source content are not taken into account in this annex.

History

Document history		
V1.1.1	January 2011	Candidate draft for DVB-TM approval
V1.1.1	TBC 2011	Pre-processed by the ETSI Secretariat <i>editHelp!</i> e-mail: mailto:edithelp@etsi.org
V1.1.1	TBC 2011	Publication